

UC-NRLF



ⓈD 29 538

**U.C.D. LIBRARY**





Digitized by the Internet Archive  
in 2007 with funding from  
Microsoft Corporation

1  
H. W. Gilmore

MANUALS OF TECHNOLOGY.

EDITED BY

PROF. AYRTON, F.R.S., and R. WORMELL, D.Sc., M.A.



SPINNING

WOOLLEN AND WORSTED:

BEING

A PRACTICAL TREATISE FOR THE USE OF ALL PERSONS  
ENGAGED IN THESE TRADES.

BY

WALTER S. BRIGHT McLAREN, M.A.

(SMITH & McLAREN), WORSTED-SPINNER.

WITH 69 DIAGRAMS.

---

SECOND EDITION.

---

CASSELL & COMPANY, LIMITED:  
LONDON, PARIS & NEW YORK.

[ALL RIGHTS RESERVED.]

1891.  
UNIVERSITY OF CALIFORNIA  
LIBRARY  
COLLEGE OF AGRICULTURE  
**U.C.D. LIBRARY**

U.C.D. LIBRARY



## P R E F A C E.



THE design of this Manual is to describe in a concise form the principles of worsted and woollen spinning, as exemplified in the machinery employed in the various processes of those trades. There are many spinners, both masters and workmen, who know their business without having paid much attention to the reasons why the different processes are employed to produce required results ; and there are probably still more who do their work by rule of thumb, and never take the trouble to make the exact calculations which are really required. No better example of this can be found than the way in which wool is generally washed, without any regard to what is best for it, but merely with a view to cheapness and obtaining a good colour. That this arises from ignorance of the structure and nature of wool is most probable, and therefore a considerable amount of space has been devoted to this branch of the subject. To those who desire to know the reasons for what they are doing, and to have in a convenient form the rules for all the calculations they require, it is hoped this book may be useful ; while to those who are not actually spinners, but who desire to have an insight into the trade, it may prove clear and instructive. 47018

It has been too much the custom to consider weaving as the one important part of the textile industries ; and in all discussions on technical education, spinning and its preparatory processes have been almost if not entirely ignored. It may be doubtful whether a spinning school would be of much use compared to its cost ; but the technology of the trade is amply sufficient to require such a work as the one now presented, while weaving may well be left for separate treatment. The present work treats of both worsted and woollen spinning. So far as I am aware, no book has ever been written on the former, and yet its processes are much more numerous and more delicate than those of the latter, and much greater exactitude is required and can be obtained in them. Regarding the woollen trade, and especially carding, much has been written, and, therefore, little that is new can be said ; but it is hoped that the method here followed may be of more practical use to the carder than has been the case with other books. The aim has been in every chapter to make the Manual such that the overlooker in every room in every mill will find it a guide in his work.

Although the worsted and woollen trades are quite separate, they have the same raw material, and the initial processes of sorting and washing are common to both. It would be better for each trade if it knew more of the other, and could take hints from it. One of the weak points in the workmen of the present day is that they only know their own branch of their own trade, and

have no opportunity of obtaining that general knowledge which increases their power of usefulness. This work may in a small degree tend to remove that defect, and will show how much there is in common between the two trades.

It has been necessary to explain the workings and construction of certain machines at some length, rather than to confine the Manual to general principles. But in any manufacturing trade, the principles can only be seen clearly when carried out in practice by the machinery, and therefore without the descriptions they would only be understood by those actually engaged in giving effect to them in daily work.

I gladly take this opportunity of thanking those friends, among whom I will only mention the Manager and overlookers of my own mill, who have kindly given me much help in preparing this Manual.

WALTER S. B. McLAREN.

*Springfield Mill, Keighley.*



# CONTENTS.



## CHAPTER I.

### THE NATURE OF WOOL.

PAGE.

1. Wool and Hair—2. Growth of Wool—3. Formation of the Fibre—4. Wool, Fibrous and Porous—5. Serratures of Wool—6. Serratures in Various Wools—7. Causes Affecting Length and Quality—8. Trueness of Breeding—9. Soundness of Fibre—10. Softness, Fineness, and Length—11. Colour—12. Felting—13. Alpaca and Mohair 1

## CHAPTER II.

### WOOL-SORTING.

14. Hogs and Wethers—15. Different Qualities of Wool—16. Range of Qualities—17. Names of Qualities—18. Form of the Fleece—19. Skin Wool—20. Wool-Sorters' Disease—21. Theory of the Disease—22. Nature of the Disease—23. Best Preventive—24. Method usually Employed . . . . . 14.

## CHAPTER III.

### WOOL-WASHING AND OILING.

25. Yolk on Wool—26. Sheep Washing—27. Advantages and Disadvantages of Washing Sheep—28. Adulterated Soap—29. Effect of Hard Water—30. Means for Softening Water—31. Receipts for Soap—32. Danger of Strong Soap and Hot Water—33. Petrie's Washing Bowl—34. McNaught's and Jefferson's Bowls—35. Dr. Braun's Machine—36. Verviers Wool-washing—37. Ordinary Hot Blast Drying Machine—38. Petrie's Dryer—39. Moore's Dryer—40. Hydro-Extractor—41. Oiling Wool—42. Best Oil to be Used—43. Oleine Oil for Woollens—44. Test for Oil—45. Quantity to be Used—46. Carbonisation—47. Methods Employed—48. Wool not Injured if Care be Taken—49. Wiesner's Experiments—50. Extraction of Oil from Soap Suds . 24

## CHAPTER IV.

## THE DIFFERENCE BETWEEN WORSTED AND WOOLLEN.

PAGE

51. Worsted and Woollen—52. Former Distinction Untenable—53. Difference not in Length, nor in Combing and Carding—54. Nor in Mule and Throstle—55. Nor in Milling—56. Difference lies in Arrangement of Fibres—57. In Worsted, Fibres lie Smooth and Parallel—58. In Woollen, Fibres lie Roughly and Crossed—59. Appearance of the Two Yarns—60. Processes Designed to Assist these Characteristics—Worsted—61. Process for Woollen—62. Definitions of Worsted and Woollen Threads . . . . . 52

## CHAPTER V.

## PREPARING AND CARDING FOR COMBING.

63. Different Treatment for Different Yarns—64. Subdivision of Processes for Worsted—65. Preparing by Gill Boxes—66. Principle of First Gill Box—67. Clough's Gill Box—68. Diagram of Clough's Gill Box—69. Set of Gill Boxes—70. Levelling the Slivers—71. Method of Oiling—72. Special Points needing Care—73. Fallers—74. Draft of Gill Boxes—75. Draft between Front Rollers and Fallers—76. Suitable Drafts for Set of Boxes—77. Preparing for Mohair and Alpaca—78. Carding before Combing—79. The Tenter Hook Willey—80. Lickers-in or Opening Rollers—81. Arrangement of a Card—82. Burring Rollers—83. Carding without Combing—84. Difference between Preparing and Carding—85. Capability for Milling not affected by Gilling—86. Back-washing—87. Card Clothing—88. Speeds of Cards—89. Modern Improvements . . . . . 61

## CHAPTER VI.

## WOOL-COMBING.

90. Hand Combing—91. The Nip Comb—92. Action of the Nip Comb—93. Chief Point of the Nip Comb—94. Setting of Nip Comb—95. Noble's Comb—96. Ground Plan of Noble's Comb—97. Feeding the Noble Comb—98. Dabbing Brushes—99. Double Drawing-off Rollers—100. Defects of Noble's Combs—101. Holden's or Square-motion Comb—102. Bailey's Noil-motion—103. Advantages of Holden's Comb—104. Other Combs—105. Balling or Top-making . . . . . 90

## CHAPTER VII.

## DRAWING.

106. Principle of Drawing—107. Drafting Twice the same Way—108. Open Drawing—109. Two-Spindle Gill Box—110. Varying Speed and Drag of Bobbin—111. Open Drawing Boxes—112. Knocker off Motion—113. Roving and Size of Bobbins—114. Botany Open Drawing—115. Drawing without Gills—116. The Ratch—117. Amount of

Draft—118. Calculations for Draft—119. Test of Calculations—120. Gauge Points—121. Corresponding Speeds of Boxes—122. Advantage of Cone Drawing—123. Principle of Cone Drawing—124. Effect of Cone Drawing—125. Variation in Speed of Bobbins—126. The Bobbin can Lead the Flyer—127. Speeds with Flyer leading Bobbin—128. Speeds with Bobbin leading Flyer—129. French Drawing—130. Effect of French Drawing . . . . . 118

CHAPTER VIII.

WORSTED SPINNING.

131. Principle of Spinning—132. Flyer Spinning Frame—133. Flyer Spinning—Twisting and Winding the Yarn—134. Calculations for Twist and Speed—135. Calculations for Draft—136. General Formulæ for Spinning—137. Cap Frame—138. Drawbacks and Advantages of Caps—139. Movable Cylinders for Cap Frames—140. Ring Spinning—141. Improved Lifter Motion—142. Important Points in Ring Spinning—143. Fox's Ring and Cap Frame—144. Mitchell's Caps for Spinning-Bobbins—145. Stop-motions for Spinning Frames—146. Worsted Mule Spinning—147. Calculations for Yarn . . . . . 150

CHAPTER IX.

WOOLLEN CARDING.

148. The Woollen Trade—149. Shake Willey—150. Blending and Oiling—151. Mixing Wool and Cotton—152. Care needed in Blending—153. Mixing Willey—154. Shoddy, Mungo, and Flocks—155. Burring Machine—156. Card-feeding Machines—Evan and King's—157. Bramwell's Weighing and Feeding Machine—158. The Scribbler—159. Functions of the Various Rollers—160. Relative Action of the Card Wires—161. Setting the Rollers—162. Lickers-in and Breast—163. The Swift—164. The Fancy—165. The Doffer—166. The Workers and Strippers—167. Grinding—168. Turning and Covering Rollers—169. Card Clothing—170. To find the Amount of Clothing Required . . . . . 181

CHAPTER X.

FEEDING, CONDENSING, AND SPINNING.

171. Intermediate Feeding Machines—172. Blamire's Feed—173. Balling Head and Creel Feed—174. The Scotch Feed—175. The Apperley Feed—176. Last Swift to be Covered with Filletting—177. Ring Doffers—178. Double Rubber Condenser—179. Single Rubber Condenser—180. Double Doffer—181. Belgian Condenser—182. Belgian Carding—183. Mule Spinning—184. Difference between Worsted and Woollen . . . . . 213

## CHAPTER XI.

	PAGE
TWISTING, REELING, AND SCOURING.	
185. Winding—186. Roller and Trap Twisters—187. Stop-Motion Twisters	
—188. Effect of Twisting—189. Reeling—190. Gassing and Scouring	
—191. Shrinking—192. Conclusion . . . . .	235
GLOSSARY . . . . .	246
INDEX . . . . .	253



## LIST OF ILLUSTRATIONS.

	PAGE
Fibres of Wool . . . . .	7
Qualities of Wool on English Sheep . . . . .	16
Petrie's Washing Bowl . . . . .	33
Jefferson's Washing Rollers . . . . .	35
Dr. Braun's Washing Machine . . . . .	37
Petrie's Dryer . . . . .	41
Moore's Dryer . . . . .	42
Hydro-Extractor . . . . .	43
Woollen and Worsted Threads . . . . .	57
First Preparing Box . . . . .	63
Clough's Preparing Box, Section . . . . .	67
"    "    "    Plan . . . . .	67
Tenter-hook Willey . . . . .	79
Carding Machine . . . . .	80
Filletting for Lickers-in . . . . .	81
Portion of Card, Section . . . . .	83
Back-Washing Machine . . . . .	87
Hand Comb . . . . .	90
Lister or Nip Comb . . . . .	92
Ball-Making Box for Noble's Comb . . . . .	98
Noble's Comb . . . . .	99
Circles of Noble's Comb, Positions . . . . .	100
"    "    "    Full Plan . . . . .	103
Dabbing Brush . . . . .	106
Double Drawing-Off Rollers for Noble's Comb . . . . .	108
Holden's or Square-Motion Comb (right side) . . . . .	111
"    "    "    (left side) . . . . .	113



## LIST OF ILLUSTRATIONS.

XV

	PAGE
Scotch Feed . . . . .	219
Double-Rubber Condenser . . . . .	223
Single-Rubber Condenser . . . . .	225
Double Doffer . . . . .	226
Woollen Mule . . . . .	230
Roller Twister . . . . .	236
Illingworth's Trap Cap Twister . . . . .	237
Boyd's Redoubler or Twister . . . . .	240



# SPINNING

## WOOLLEN AND WORSTED.

---

### CHAPTER I.

#### THE NATURE OF WOOL.

1. **Wool and Hair.**—To understand the processes of the worsted and woollen trades, and the principles which underlie them, it is necessary to be familiar with the growth and nature of wool. It is hard to say exactly what is the difference between wool and hair. Chemically they are the same; and though few persons accustomed to wool would have any difficulty in saying which of two samples was wool, and which was hair, yet the fine hair of some animals grows so like fine wool, and the coarser wool of some sheep becomes so like strong hair, that no exact division can be made between the two materials. Wool, indeed, is but a variety of hair. The distinguishing marks between the two are chiefly that a hair lies straight, and, if examined under a microscope, is seen to have a comparatively smooth surface. Wool, on the other hand, is waved, and its surface is covered with almost innumerable scales or serratures, all of which point from the root to the tip, and thus give it an appearance like the edge of a saw or a fir-cone.

2. **Growth of Wool.**—The growth of wool is, in its chief features, similar to that of hair. Mr. Youatt, a well-known writer on the subject, thus describes its development and anatomy:—"The skin of the sheep, and of animals generally, is composed of three textures. Externally is the cuticle or scarf-skin, which is thin, tough, and devoid of feeling, and pierced by innumerable holes,

through which pass the fibres of wool and the insensible perspiration. Below this is the rete mucosum, a soft structure, its fibres having scarcely more consistency than mucilage, and being with great difficulty separated from the skin beneath. Below this is the true skin, composed of innumerable minute fibres, crossing each other in every direction, highly elastic in order to fit closely to the parts beneath, and to yield to the various motions of the body, and dense and firm in its structure that it may resist external injury. Blood-vessels and nerves, countless in number, pierce it, and appear on its surface in the form of papillæ, or minute eminences, while through thousands of little orifices the exhalent absorbents pour out the superfluous fluid. In the fatty and cellular substance immediately beneath the cutis, or true skin—some say embedded in the true skin—there are numerous minute vascular bulbs; they arise from the cellular texture, and penetrate into the true skin; they consist of a double membrane, the outer one of which stops at the pore, or minute aperture in the skin, and between the two membranes a vascular texture has been traced. From the interior and centre of the inner membrane there proceeds a minute eminence or papilla, which, surrounded by the membrane, projects into and through the cutis, while numerous fine filaments unite to form or to surround a seeming prolongation of the original papilla. In this way it gradually penetrates the cutis, the rete mucosum, from which it takes its colour, and then, either pushing its way through the cuticle—the displaced portion of which falls off in the form of scurf—or carrying a part of the cuticle with it as a kind of sheath, it appears under the form and character of hair.”

3. **Formation of the Fibre.**—It must not, however, be supposed that a fibre of wool is a solid structure forced through the skin in the form in which it is afterwards seen. The papilla just mentioned is composed of a great number of very minute cells containing fluid, which is obtained from the blood when that is in a

proper condition for supplying it. These cells group together, some in the centre, others round them. As they force their way through the cuticle, the fluid evaporates from those at the outside, causing the membrane which forms the cell to collapse; and thus the fibre is created by all the fluid in those cells evaporating, and their walls shrinking in, and forming a small hollow stalk or fibre, which is round or oval because the cells shrink simultaneously as they are projected through the skin. These shrunken cells form the serratures or saw-like edges which we have mentioned, and of which we shall presently say more. Just as in a saw or a fir-cone each point overlaps the base of the one in front of it, so do the serratures of wool overlap each other. The reason of this is clear. As any given cell comes out from the skin the part in front shrinks first and forms a point. The remainder shrinks in its turn, and is flattened down. The next cell succeeding it is pushed forward, and overlaps its predecessor, forming for itself a point which covers the base of the one before it, precisely in the same way as one point in a fir-cone covers the base of the point in front of it. There is, however, this difference, that wool being gelatinous and of the same nature as horn, the membrane comprising the cells sticks together, and as each soft cell comes out, it forms both a partial covering and bed for its predecessor, and thus all together make one compact and continuous fibre. It must be remembered that as the fibre is composed originally of cells, though dried up and shrunken, the cells always remain, and, under suitable conditions, can revert to some extent to their former nature. Being like horn, they can also be dissolved. It is these two facts which make the operation of washing of so much importance, and underlie the property of felting or matting, which is so characteristic of wool, and which, in brief, may be described as that property which enables a number of fibres, whether woven or merely compressed, to interlock and join together, so that they

form one compact whole, and each fibre can no longer be separated, or even distinguished.

4. **Wool, fibrous and porous.**—Wool has a fibrous nature, and can be split easily ; indeed, when an animal is in an unsound state of health, its hair naturally splits from the point towards the root. It grows from the root, and constantly receives nourishment from the vessels belonging to its bulb. These vessels continue a short way beyond the root, and in the case of a certain disease which affects human hair, known as *pica polonica*, they enlarge even to the extent of allowing blood to pass up the hair, so that each separate hair, when cut, bleeds. This seems to prove that the fibre is a fine tube, although some persons have contended that it is flat and solid. In good health it contains a sort of pulp or oil which gives it softness, and adds to its brilliancy. When clean it is also translucent, and some sorts have a brilliant shining surface, known as lustre. This, however, depends on the breed of the sheep, and the way in which it has been fed and attended to ; lack of lustre does not, therefore, imply any inferiority in the wool, as some of the finest and best wools are without it, and are nearly opaque, as are also dark-coloured wools.

5. **Serratures of Wool.**—As it is very important that the structure of the fibre should be thoroughly understood, with regard especially to the varying serrations in different classes of wool, and their forms, Mr. Youatt's description is well worth quoting. He says :—“There can be no doubt with regard to the general outline of the woolly fibre. It consists of a central stem or stalk, probably hollow, or at least porous, and possessing a semi-transparency not found in the fibre of hair. From this central stalk there springs, at different distances in different breeds of sheep, a circlet of leaf-shaped projections. In the finer species of wool these circles seemed at first to be composed of one indented or serrated ring ; but when the eye was accustomed to them this ring was resolvable into leaves or scales.



In the larger kinds the ring was at once resolvable into these scales or leaves, varying in number, shape, and size, and projecting at different angles from the stalk, and in the direction of the leaves of vegetables, *i.e.*, from the root to the point. The extremities of the leaves in the long merino and Saxon wools were evidently pointed with acute indentations or angles between them. They were pointed also in the South Down, but not so much, and the interposed vacuities were less deep and angular. In the Leicester, the leaves are round with a diminutive point or space. Of the actual substance and strength of these leafy or scaly circles, nothing can yet be affirmed, but they appear to be capable of different degrees of resistance, or of entanglement with other fibres, in proportion as their form is sharpened and as they project from the stalk; and in proportion, likewise, as these circlets are multiplied. So far as the examination has hitherto proceeded, they are sharper and more numerous in the felting wools than in others, and in proportion as the felting property exists. The conclusion seems to be legitimate, and indeed inevitable, that they are connected with, or, in fact, that they give to the wool the power of felting, and regulate the degree in which that power is possessed.

“If to this is added the curved form which the fibre of the wool naturally assumes, and the well-known fact that these curves differ in the most striking degree in different breeds, according to the fineness of the fibre, and, when multiplying in a given space, increase both the means of entanglement and the difficulty of disengagement, the whole history of felting is unravelled. A cursory glance will discover the proportionate number of curves, and the microscope has now established a connection between the closeness of the curves and the number of serrations. The Saxon wool is remarkable for the close packing of its little curves—the number of serrations are 2,720 to an inch; the South Down has numerous curves, but evidently more distant—the serrations are 2,080. In the Leicester, the wavy curls are

far removed from each other, and the serrations are 1,860; and in some of the wools which warm the animals, but were not intended to clothe the human body, the curves are more distant, and the serrations not more than 480. The wool-grower, the stapler, and the manufacturer, can scarcely wish for better guides."

6. **Serratures in Various Wools.**—Any one can verify these observations for himself. Take some hairs and some fibres of South Down wool and hold them together. The hair will hang straight and smooth, the wool will be curly, something like a corkscrew, and will have a waved appearance. If it is passed between the finger and thumb, beginning with the root end, and drawn out towards the point, it will feel smooth; but if the reverse way, it is sometimes possible to detect a feeling of roughness, as if the fibres were resisting the pressure and passage of the fingers. With a microscope there is no difficulty in seeing the teeth-like edges which thus catch the fingers. They are generally likened to the edge of a saw, but the outside structure of wool is really more similar to that of a long thin fir-cone, rather thicker at the root than at the point, and covered with minute scales which stand out all the way round, and not merely at two flat edges like saw-teeth.

The annexed diagram (Fig. 1) representing various wools, will illustrate this. The first five are each shown twice, as semi-transparent and opaque. In the former state they show the saw-like edges most clearly, but in the latter they appear as they really are, scaly indented fibres, with leaves lapping over each other like a fir-cone. A is a fibre of merino wool, short, fine, and white, and suitable for fine cloth. Its diameter is about  $\frac{1}{1200}$  of an inch, and each inch has about 2,400 serrations. E is the finest Saxony wool, a cross between Spanish merino and native Saxon, and is one of the finest in the world. Its diameter is about  $\frac{1}{1370}$  of an inch, with 2,720 serrations. The next in fineness is B, the South Down wool, about  $\frac{1}{1100}$  of an inch, with some 2,000 serrations. C and D

are Leicester and Lincoln, both stronger, but the latter, which is the longest, heaviest, and brightest of English

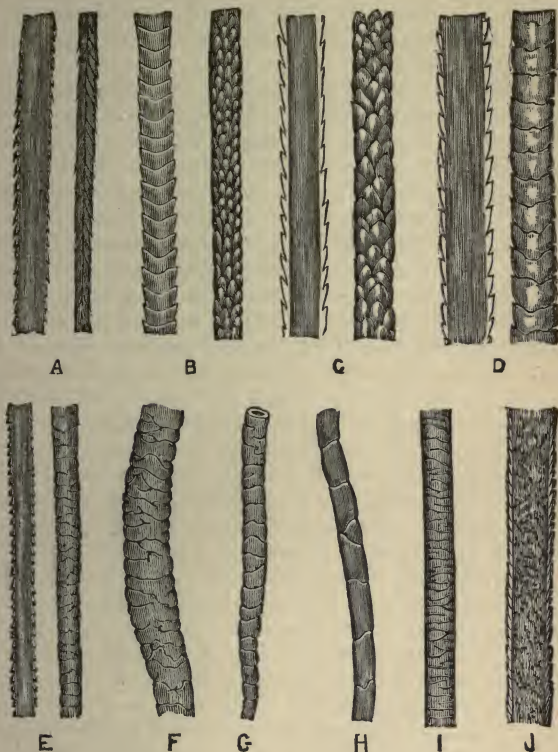

Fig. 1.

wools, has comparatively few serrations, and therefore has large scales. F is common wool, G is goat's hair, and H mohair, the brightest of all wools and closely resembling hair in every respect. Cow-hair and human hair,

I and J, are also given, the last being of all kinds of hair the softest and most wavy, though very different from the good wools. The coarsest English wool is about  $\frac{1}{400}$  of an inch in diameter. The finest of all wools is said to be the American merino, with a diameter of  $\frac{1}{1800}$  of an inch.

7. Causes affecting Length and Quality.—The three causes which affect the length and quality of wool are the breed of the sheep, the climate, and the soil. These might be reduced to two, for the breed of the sheep ultimately depends on the climate and the soil; but it is more useful to consider different breeds as quite distinct. The present breeds have been obtained in some instances by careful selections of those sheep which had a tendency to produce such wools as the grower desired and as the climate favoured; until now some sheep will only grow short wool if left in their native district. In other instances, probably the most numerous, Nature has decided for herself what length and quality of wool the sheep must produce in each country; no matter what efforts the farmer may make to the contrary, he can only permanently rear short-woolled sheep where Nature favours short wool, and long-woolled sheep where she favours length. For instance, South Down sheep grown on the light soil and in the warm climate of the South of England produce short fine wool. If they were taken to the heavy soil and wet climate of Lincolnshire, they would gradually grow long and strong wool, which in time would become bright. The Australian sheep were originally imported from England, though they have been crossed with merino sheep. They now grow short fine wool, much finer than anything produced in this country. The farmers there, wishing to increase their weight of wool, cross the breed with Lincoln and Leicester rams. The first year the young sheep give long bright wool, the second year it is much shorter and finer, and each year that the sheep is allowed to live it grows still shorter and finer, till it becomes nearly like the ordinary

Australian wool. What is the exact part played by climate and what by soil—which means quantity and quality of food—it is not possible to tell, but it is certain that in the case of sheep more quickly than in the case of any other animal Nature provides just such a covering as they need for proper warmth. One writer has said that “sheep carried from a cold to a warm climate soon undergo a very remarkable change in the appearance of their fleece. From being very fine and thick, it becomes thin and coarse, until at length it degenerates into hair.” This statement has been endorsed by others, but, as has been shown from the example of Australia, it is by no means correct. It seems, however, approximately correct of East Indian sheep, which grow short strong wool, in some cases like hair, and most of it cross-bred and kempy. It is highly probable, however, that this is due to bad breeding and defective nourishment, and that if merino sheep were taken to India they could be reared with success.

8. **Trueness of Breeding.**—The property for which wool is perhaps most valued is trueness of breeding. In a true-bred sheep each staple of wool, that is, each lock into which a group of fibres naturally forms itself, will be of equal growth throughout. The fibre will be the same thickness as nearly as possible the whole length, or will be finer at the point than at the root. There will be no shaggy rough wool in it. But if the sheep be cross-bred or ill kept and exposed to storms, the fibres will be rough at the points, and coarser there than at the roots; the reason of this being that as the wool gets longer, or as it is more exposed to bad weather and hard treatment, nature makes it stronger to resist what it has to encounter, while the part which is next the skin remains fine to give greater warmth. Such wool, even when combed and spun into yarn, never lies as smoothly and evenly as true-bred wool, and is consequently not of as much value. There is another sort of wool which farmers do not seem to understand, and writers on the subject

often ignore, but which is found more or less on all cross-bred sheep, and on sheep which are much exposed and fed in hilly districts. This is known as "kemp" or dead hairs. These kemps vary in length and coarseness according to the breed of sheep. In white Highland sheep they are about two inches long and very thick; in cross-bred Australian they are very short. In the former they cover the under side of the fleece so as almost to hide the hair; in the latter they are so few as not to be of any importance. They are, however, all alike in this, that they are a brilliant shining white (except on sheep with grey wool, when they may be black), and they will not dye the same colour as the rest of the wool. They consequently depreciate the value of the wool very greatly, making it only suitable for low-priced goods. They seem to be fibres of wool, which, owing to the coarseness of the breeding of the sheep, or owing to its exposure to rough weather, have been killed, so far as power to grow long is concerned; but they grow in thickness and hardness till they become solid, glazed, and horny, and thus are unable to receive the substance of the dye. They never alter in the processes of carding, combing, or spinning, nor do they unite with the rest of the wool to form the thread, but lie on the surface, only held down by other fibres of wool which may be wrapped round over them. It should be the object of every breeder of sheep to diminish, if possible, these very kempy varieties of wool.

**9. Soundness of Fibre.**—The property of wool next in importance is soundness of fibre. It is clear that if the fibre is tender in the middle, it will break during some process of working, and thus the thread is weaker, and all value derived from length of wool is lost. Tenderness arises from ill health and neglect of the sheep, and is seen at once by the fibre being thin in some part; just as when a person is ill, those portions of his finger-nails which are being formed during his illness grow and always remain thinner than the rest, so when a sheep is

ill or half starved, the portion of wool grown at the time is thin and tender. This can be most readily detected by pulling a small staple tightly from both ends, when, if it be tender, it will give way.

10. **Softness, Fineness, and Length.**—In softness, fineness, and length wools vary according to the breed, and just as any wool combines all three qualities so it is valuable. Whether wool which is fine but short is more valuable than that which is stronger but long, depends on the use to which they are to be put. Very fine wool is never, however, of great length. Strong wools grow from one to twenty inches long. Lustrous wools belong to the longer and stronger varieties, fine wools are usually devoid of any gloss, but are very much softer to the touch.

11. **Colour.**—With regard to colour, other things being equal, wool which is pure white is most valuable, but there are some sorts of fine natural browns which are also much prized. The soil has much to do with the colour. Sheep which are fed on rich grass lands have pure white wool, but those fed on sandy and red-tinged soil become more or less yellow, and even after washing the wool is not the brilliant white which is seen in wool grown in clear pure air on good grass lands. Some wools are brown, black, grey, and even bright yellow; among these last are certain qualities of Egyptian and East Indian. These colours are due to the nature of the sheep, and are probably beyond the power of the farmer to alter.

12. **Felting.**—From what has been said it will not be difficult to understand the reason why wool can be felted, though the process and the machinery for carrying it on will not be described here. Felting is, in the first place, due to the wavy, curling nature of the wool, which inclines it to twist round anything it catches, but it is chiefly due to the structure of the wool in the cells already described, and to the saw-like edges which they form. The serrated edges of the fibres fit into each other, and lock fast, under the pressure of heavy weights used in the

process, and thus the piece of cloth which was formerly seen to be made of separate threads, after felting seems to be one solid mass. This process can only be carried on when the cloth or wool—for it does not need to be woven—is wet, and warm water is more efficacious than cold, while the addition of acid greatly facilitates it. There does not seem to be any definable limit to felting, and to what always accompanies it—shrinking. As any one who uses flannel is aware, it continues to become more matted, thicker and smaller in length and breadth, every time it is washed. We have seen a piece of worsted cloth, with both warp and weft made entirely of combed long English hog wool, shrink after two hours' milling into one-third of its former dimensions, and become like a piece of flannel. The reason appears to be that as the fibre is composed of countless little dried-up cells made originally of soft gelatinous membrane, when these are put into hot water, the cells partly expand, and become soft; if there is acid in the water, it acts so much more quickly on the membrane in softening it. A small fraction of the membrane may be entirely dissolved, but even where this does not take place the cells are made soft. They are then beaten or pressed with heavy weights, and so are squeezed, or to a certain extent even glued together, and just as the fibres in one thread are thus firmly joined, so the fibres in different threads are also united. It is not, however, merely a question of binding them together. They shrink in the process. The cells being once softened do not return to their former positions when dry again. They seem to shrink into each other more than before, and thus the fibre becomes thicker and shorter, and the cloth "runs up" to an indefinite extent. In cotton and linen there is no such shrinkage. Their fibres are not formed of cells, but being vegetable are in continuous lengths. It is this shrinking property whereby woollen cloth is made into a compact solid mass that makes it so suitable for clothing, because, being solid, the cold air cannot well penetrate it, and it is also a non-conductor of heat. Were it con-



ducting, it would afford no proper covering for sheep or other animals, for they have to depend on its non-conducting nature only, and not on its felting properties. These latter appear to be given to it entirely for the benefit of man; certainly they do the sheep no good, for if the wool felted on the sheep's back it would become full of dirt, besides being of little use to mankind. It may be asked why it does not felt on the sheep's back. It is often wet, which is one requisite, and is rubbed and pressed when the sheep is lying down. The answer is simple: Because all the fibres are lying one way. The serrations, as has been said, always point in the direction away from the root of the fibre, and thus they cannot fit into each other any more than two saw-edges pointing the same way could interlock, or than two fir-cones could stick together if they both lay in the same direction. But reverse one of them, and then try to draw it past the other while touching it, and they will at once become fastened together. In like manner, during the various processes of manufacture, the fibres of wool are pulled about in every direction, and thus their edges are placed with many of the points facing each other, and ready to seize hold when the felting operation begins. As will be seen, too, later on, this same property is of assistance in spinning, and is one of the reasons why fine wool is more easy to spin than coarse wool of greater length. The amount of grease and dirt which is in the wool while on the sheep's back also tends to prevent it from felting, as the serrations are more or less filled up, and thus unable to take hold of each other.

13. **Alpaca and Mohair.**—It is not within the scope of this book to give a special account of various kinds of wool, but alpaca and mohair require a few words of special mention. The former is the wool of the Peruvian sheep, which is really a species of llama, a genus allied to the camel and dromedary. Its wool is very bright and soft, and in colour is white, brown, and black. Mohair, which comes from the Angora goat, is very long and

silky, and is the brightest and most lustrous of all classes of hair or wool. The best and cleanest is white, and comes from the central districts of Asia Minor. Brown mohair is grown about two hundred miles south of Angora, and is much more dusty than the white, while Van mohair, from Lake Van, is a lower quality, and exceedingly dusty. The mohair goat is also reared in the Cape of Good Hope, and large quantities are imported from that district. It is, perhaps, more proper to consider these as hair rather than wool, for they are more akin to it, but the processes of their manufacture are, in their main features, the same as those for wool. As alpaca and mohair are both valued for their lustre, they are not felted, and though, no doubt, they could be felted were it necessary, they are, for many reasons, unsuited to the process.

---

## CHAPTER II.

### WOOL-SORTING.

14. **Hogs and Wethers.**—It is not enough merely to know the nature and properties of wool. It is necessary to be able to “sort” it. In the cotton trade there is comparatively little difficulty in this respect. The varieties of cotton are few, and each bale contains, or should contain, only one quality. But every fleece of wool contains six or eight different qualities, all of which must be separated from each other if an exact division is required, and as the number of varieties of sheep is really unlimited, the field open to the wool-sorter is indeed wide. The first point to be understood is the difference between the wool of lambs and one-year-old sheep, and that of sheep of two or more years of age. The former is called Hog, or Hogget, and is naturally pointed at the end, because it has never been clipped; the staples too, which each group of fibres forms, are

also pointed and taper out into long thin ends. The latter is generally called Wether. The fibre ends having once been cut are never so pointed, and the staples have thick and rougher tips. Hog wool is more valuable, longer—being generally fourteen months' growth—finer in quality, and possesses more of that wavy, curling nature which makes it cling to other fibres, thus assisting the process of spinning. On account of the difference in value it is necessary to tell at once a hog fleece from a wether. This can be done in two ways; either by examining the staple-ends to see whether they are pointed or thick; or, if this is uncertain, as it sometimes is, by pulling a staple out of the fleece. If it be a wether, the staple will come clean out without interfering to any extent with the surrounding staples; but if it be a hog, some of the fibres of the other staples will adhere to the bottom of the one being pulled, and thus be dragged out after it. Hog wool is generally dirtier and fuller of moss, straw, or other vegetable matter; no doubt, because the lambs are less careful where they go than are older sheep.

15. **Different qualities of Wool.**—To give an idea of how the qualities of wool vary the following diagram (Fig. 2) has been prepared, showing approximately where each quality is to be found on an ordinary English sheep; but it must be observed, that a wool-sorter accustomed to strong, coarse, English fleeces, would be at a loss how to proceed if placed before a pile of South Downs or fine Botany wool, because the latter being throughout so much finer, either has not the same range of qualities or is much more difficult to separate.

No. 1 is the shoulder, where the wool is long and fine; it grows the closest and is most even. No. 2 is rather stronger, but otherwise equally good; the best and soundest wool grows on these two parts. No. 3, on the neck, is shorter than No. 1, but even finer; where sheep are liable to have grey wool it is sure to be found here, and also on No. 4, which, with No. 5, grows wool

of inferior staple and faulty character. No. 6, which covers the loin and back, is coarser and shorter, while on No. 7 the wool is long, strong, and hangs in large staples. On cross-bred sheep this part becomes very coarse, and is much the same as No. 8, which is the coarsest part of the wool, and is known as breech, or britch, and even when very strong, as "cow-tail." When like this it almost resembles horse-hair, though it is more

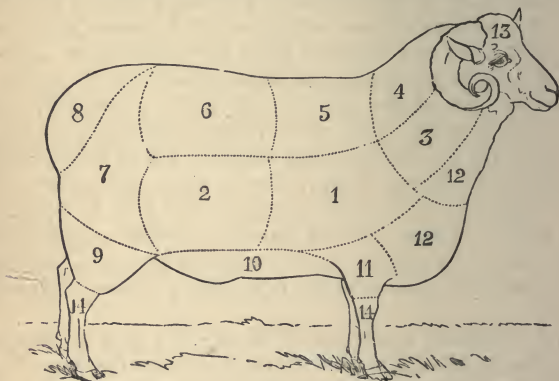

Fig. 2.

brittle, and not so smooth and bright. No. 9 is also strong, and much the same as No. 7. No. 10 is short, dirty, and increases in fineness as the front legs are approached; it is known as "brokes." No. 11 is also short and fine, while No. 12, the front of the throat, is short and worn with rubbing. Kemps, or dead hairs, are mostly found in Nos. 12 and 8, though in the latter they are much longer and stronger than in the former. No. 13 is the head, on which the wool is very short indeed, rough, and coarse. On the legs, No. 14, it is still worse, and of very little value. For the idea of this diagram I am indebted to the *Textile Manufacturer*, as also for the following table of

qualities. It will be seen that the quality of the wool varies in the same way as the quality of the mutton. The shoulder of mutton is finer in grain and more delicate than the leg, and so is the wool; there is more wear and tear, too, for the sheep in its haunches than its shoulders, for the weight is chiefly there when it lies down; consequently the wool is longer and stronger. If the wool about the neck were as long as at the tail, the sheep could not get through hedges and briars, and it would also be weighed down while eating; therefore Nature provides that the wool shall be short and fine—just enough to keep the animal warm. The wool on the back becomes rough and thin, being most exposed to the rain, and because it naturally divides down the ridge of the back, it falls over to each side.

16. **Range of Qualities.**—As has been said, the range of qualities is not the same in sheep with fine wool as in those of stronger breeds. The different breeds may be compared to the key-board of a piano: each sheep has its octave of qualities, but the octave of the Merino sheep is very high, while that of the Lincolnshire sheep is very low. The following table shows the range for a number of varieties, and illustrates the principle well. English wools vary so much that it would require many tables to show their range. The range which each sheep has is not, however, very great, Lincolnshire wools being suitable for Nos. of yarn between 36's and 20's, Yorkshire wool between 44's and 20's, while South Down wools have a range at very much higher counts.

17. **Names of Qualities.**—Wool-sorters, however, do not call their qualities by the names of the parts of the sheep; they have names varying in different localities. In the woollen trade the following names are common for English wool:—picklock, which, as the name implies, is the choicest of all; prime, which is very similar; choice, a very little stronger; super, from the shoulders; seconds, the best bits from the breast;

COMPARISON OF WOOLS OF DIFFERENT SOURCES, WITH THEIR DIAMETER, AND  
THE CORRESPONDING NUMBER OF YARNS.

Sorting Number.	Wool from							Nos. of Yarns suitable for	Diameter of the Filaments.
	Silesia.	Saxony.	Australia.	Champagne.	Spain.	North of France.	Algeria.		
1	Extra fine							225	From 0.015
2	Superfine	Extra fine						180	
3	Fine	Superfine	Extra fine					160	to
4	Semi-fine	Fine	Superfine	Extra fine				145	
5	Medium	Semi-fine	Fine	Superfine	Extra fine			130	0.025
6	Coarse	Medium	Semi-fine	Fine	Superfine			120	From 0.025
7	Very coarse	Coarse	Medium	Semi-fine	Fine			105	
8		Very coarse	Coarse	Medium	Semi-fine	Extra fine		95	to
9			Very coarse	Coarse	Medium	Superfine		85	
10				Very coarse	Coarse	Fine	Extra fine	70	0.045
11					Very coarse	Semi-fine	Superfine	55	From 0.045
12						Medium	Fine	30	
13						Coarse	Semi-fine	25	to
14						Very coarse	Medium	20	
15							Coarse	15	
16							Very coarse	10	0.075

downrights, the strong wool of the side, marked No. 2 ; abb, which is between these two ; breech, from the part marked No. 8 ; and head, from the head. In the worsted trade these names are not used, the following being those generally adopted :—blue, from the neck ; fine, from the shoulders ; neat, from the middle of the sides and back ; brown-drawing, from the haunches ; breech, or britch, from the tail and hind legs ; cow-tail, when the breech is very strong ; and brokes, from the belly and lower part of the front legs, which are classed as super, middle, and common, according to their quality. For finer sorts of wool there are no special names, and Botany and similar fleeces are sorted according to their numbers or the counts of yarn they will spin to, such as 50's, 70's, 80's, and so on.

18. **Form of the Fleece.**—When the wool comes into the sorter's hands, each fleece is rolled up into a ball by itself, and generally tied with a sort of rope made out of part of itself, the shoulder being often used for this purpose, as it can be twisted most conveniently into a cord. If properly wrapped up, the fleece should be quite easy to open, and when spread on the floor its different parts can be at once recognised. A thin ragged line, which represents the back of the sheep, divides the fleece in two, and by this the sorter separates the two halves, placing them on a pile at his side. He is furnished with a number of skeps equal to the number of sorts or qualities he has to make, and then spreading half a fleece on the bench before him, he proceeds with shears to clip off all pieces of tar and hard dirt, to pick out straws and other vegetable matter, and then separates the fleece into its different qualities. A perfect knowledge of these qualities can only be gained by years of experience ; but when once acquired, the sorter knows as well by his hands as by his eyes where he shall divide the fleece, for it is not merely the coarseness or fineness of the fibre which guides him, but also the softness and kind "handle," as it is called. He is aided, too,

by seeing the half-fleece stretched out before him, and therefore he knows where to expect each quality ; but this is to him only a secondary matter. Some fleeces are much more difficult to open than others, and require either to be beaten or warmed. Fine Australian fleeces, which are packed in bales unwashed, and have perhaps 60 per cent. of grease on them, become quite hard if left cold, owing to the grease and dirt upon them becoming stiff, and they can only be opened by being pulled to pieces. They are therefore warmed, the grease on them softens, the fibres expand and are raised up, and the fleece opens quite easily. It will be seen later that wool is easier to work in certain processes when hot than when cold. The reason is, that when cold, or pressed hard together, the fibres lie closer, their serrations fit into each other and become matted. Hence, they cannot be drawn out without risk of breaking, and without the expenditure of greater power. But when heat is applied, the fibres expand, and in doing so free themselves from each other, and can be drawn out with much more ease.

**19. Skin wool.**—There is another sort of wool not hitherto mentioned, known as “skin wool.” This is wool which is taken off the skins of sheep that have been killed, or have died from disease or other causes. It is not clipped off the skin, as is done when sheep are shorn, but the skin is rubbed with lime and water, or with acid, and the roots of the wool are thus loosened. The wool is then pulled out by the roots, and the skin left entirely free. Sometimes, in the case of certain breeds of one-year-old sheep, the wool thus pulled off adheres so much together that it retains the form of the fleece, and it is then called “fliped wool” ; but usually it breaks up into smaller portions, and all trace of the shape of the fleece is lost. It comes off full of lime, and the sorter is often covered and annoyed with dust, which gets into his throat, and causes much irritation. To lessen the annoyance, sorters’ boards are always made of wooden spars with spaces between, or wire gratings, through which



much of the dust falls. But in the worst classes of wool this is not enough, and the dust, if allowed free course, occasionally causes blood-poisoning, and the death of the unfortunate sorter.

20. Wool-sorters' disease. — So much has been heard of "wool-sorters' disease," that its nature, causes, and method of preventing it should be briefly explained. For much of the following information regarding it I am indebted to Dr. Rabagliati, of Bradford, who has devoted great attention to the disease, and has written upon it. The disease first appears as an ordinary cold, accompanied with headache, oppression of the chest, and much perspiration. Then the temperature gradually becomes high, and the pulse irregular, intermittent, and weak. A cough comes on, with hurried respiration; the pulse gets weaker and weaker, till the man dies. The whole illness lasts but three or four days. If a *post-mortem* examination is held, the blood is found to be full of innumerable minute germs of fungus, known as *bacillus anthracis*.

These bacilli are quite different from blood corpuscles: they are small rods, and are accompanied by tiny particles of granular matter. The rods measure from  $\frac{1}{2000}$  to  $\frac{1}{1000}$  of an inch in length, and one-sixth or one-eighth of that in width. "If some fluid containing these rods," says Dr. Rabagliati, "be now placed for a few hours in a favourable position and warmed, changes may generally be seen to take place. The little rods grow by additions to their length, though the breadth remains the same, and we may observe the little rods of  $\frac{1}{1000}$ th of an inch spread over the whole microscopic field. As to the granular matter, which can be seen mixed up with the rods, there can be no doubt that some of it is spores, or seeds capable of reproducing the whole organism. The spore often divides into two by a transverse division, and these again each into two; so that a spore originally single may become four. If these sub-divisions be watched in favourable circumstances, they may be

observed to lengthen out at one side till they produce the little rods, and these in turn lengthen out, as we have already seen, till they obtain a comparatively great length."

21. **Theory of the Disease.**—Now, the theory is that these bacilli pass with the dust from certain classes of wool into the lungs of the sorter, and thence into his blood. Dr. Rabagliati sums up the proof as follows: "The organism can be found in the washings of infected wools. It can be found in the blood and tissues of men who have been in contact with such wools. When the fresh blood containing it is injected under the skin of animals, the animals will die in from one to four days, and their blood and tissues will in turn be found loaded with the organism. Blood from these last animals may be employed in a similar way on other animals, and with like results. Ordinary blood, fresh or putrid, has either no effect when injected into animals, or if it has, will not produce this organism." The name "wool-sorters' disease" is, perhaps, too vague, and the malady should rather be called "anthracæmia," implying a disease in which the *bacillus anthracis* is found in the blood.

22. **Nature of the Disease.**—Until lately it was believed that the disease was caused by the putrefaction of simple animal matter, such as pieces of skin and blood adhering to the wool, which poisoned the blood of the sorter; but the researches of Dr. Rabagliati and others show this to be incorrect. How, then, does the *bacillus anthracis* get into the wool? The Angora goat, the Peruvian alpaca sheep or llama, and sheep in all countries, are liable to a disease known as splenic fever, which is caused also by this same *bacillus anthracis*, and is practically the same as wool-sorters' disease. Those animals which have it die, and their owners, unwilling to lose the wool, shear it off and pack it with the wool from the rest of the flock. It is either infected by the mere fact of the animal having the disease, or some part of the skin is clipped with it and

thus carries the germs. These fleeces are called "fallen fleeces," and can be distinguished from the rest; one of them, if infected, may contaminate the whole bale, and thus cause the sorter to run the greatest risk. Though all sheep may have this disease, yet it is found that the danger only arises from the following wools, all of which are imported full of dirt and dust, both animal and mineral:—Van mohair, which is the worst of all; Persian wool; camels' hair; alpaca; Turkey mohair; brown mohair; Cape mohair; and cashmere from Tibet. The total quantity of these is comparatively not great, and means could be taken to reduce the danger arising from them.

**23. Best Preventive.** — The obvious preventive, as Dr. Rabagliati points out, is to exclude fallen fleeces when the wool is being packed, and to have all the wool washed, either before shearing, where that can be done, or before packing where the former is impracticable. If this were done, there could be no danger of the recurrence of this fatal disease, and, apart from the saving of life, it would be the cheapest method that could be adopted. At present these bales contain immense quantities of dust, specimens of which Professor Frankland has analysed. He finds that the dust of Van mohair contains 58 per cent. of animal matter, the rest being mineral; the dust of brown mohair has 51 per cent. of animal matter, and that of alpaca 40 per cent., much of which must necessarily contain impure and poisonous matter, to say nothing of the fatal fungus germs which go with it.

**24. Method usually Employed.** — The method for removing the dust employed by those firms who use these dusty wools is generally somewhat as follows: The bales are cut open in a small room with a false floor consisting of an iron grating, a couple of feet above the real floor. A trunk or shaft is conveyed from this space to the open air, and in it is fixed a circular fan which revolves 700 or 800 times a minute. It draws the air from the room

where the bales are being opened, and blows it out into the air; in doing which, so strong a draught is created that all the dust, which comes out in clouds from the bales, is drawn down and rarely rises to the height of the opener's head. In this way the opener is able to shake much of the dust from the fleeces, and to give them to the sorter comparatively clean. In some mills, notably in that of Messrs. Clough of Keighley, this principle is carried still farther. The wool-sorters' boards run down the length of a long room. In the sorting-board, opposite which each man stands, is a grating about 15 inches square covering the top of an air-tight trunk. These trunks are all connected with each other below the boards by means of a longer one which runs the entire length of the room. Attached to this is a fan of great power which draws all its air from the gratings, and blows it out of doors, carrying with it almost every particle of dust which comes out of the material which the men are sorting. Owing, no doubt, entirely to this simple but effectual safeguard, no case of disease has been known in this mill. Other remedies have been suggested, such as subjecting the wool to great heat to kill the germs before sorting, or washing it in hot soap and water, and sorting it while still damp, but these are open to many objections, and might not in the end prove effectual. The only thorough remedy must be applied before the wool is packed—that is, to keep out diseased fleeces, and to wash the wool whenever possible.

---

### CHAPTER III.

#### WOOL WASHING AND OILING.

25. *Yolk on Wool.*—Having thus far examined the nature of wool and seen it sorted into its different qualities, we come to the important, but too little cared

for, process of washing. Before the fleece is clipped from the sheep's back it is dirty, not merely with earthy matters, but with grease or "yolk"—a yellow oily substance, which is mainly caused by the accumulated sweat of the preceding year, and by a secretion from the glands of the skin. As might be expected, this yolk is found most abundantly on sheep in hot climates, and prevails to such an extent that the clean wool is often only one-third of the total weight of the fleece, the remainder being yolk and dirt adhering to it. Merino fleeces average 40 per cent. of yolk, 27 per cent. of earthy matter fastened by it, and 33 per cent. of wool, though these figures naturally vary according to the district in which the sheep have lived, and take no account of the excessive moisture which the wool may contain. The yolk itself consists mainly of potash, animal oil, a small quantity of carbonate of potash, traces of acetate of potash, of lime, and of muriate of potash. This yolk is of much value in softening and preserving the wool while it is growing, for it both oils it and keeps the sheep warm, thus tending to produce sounder and better wool. In hilly countries farmers smear their sheep over with salve, which is supposed to keep them warm during the cold autumn nights before the new fleece has had time to grow long or the fresh yolk to be formed.

26. **Sheep-Washing.**—It is obvious that all this yolk must be removed before the wool can be used by the manufacturer, and this should be done in such a way as not to injure the fibre of the wool. In most cases the farmers wash or half-wash the fleece before shearing, and though this has some advantages to the manufacturer the gain on the whole is very doubtful. The yolk, in consequence of the potash and oil in it, is a most valuable manure, while the animal dirt which may be adhering to the fleece is also worth preserving. The farmer, however, loses it all by washing the sheep in a running stream. The old-fashioned way of doing this was for two men to stand in a pool in the stream, take one sheep at a time, plunge it

in the water and scrub it till it was moderately clean, and then let it run about for a few days till it was dry, when it was shorn. A later improvement is to put each sheep in a perforated box or barrel, and then wash it, the effect being the same. A still more thorough and wholesale way is in use in Australia, where the sheep are fastened into pens underneath iron perforated pipes. Water is forced into these pipes with great pressure, and allowed to run some time till the sheep are half washed. They then go singly down a passage till they come to the stream, into which they are plunged, and from which the only egress is by swimming down a small tunnel, thus ensuring a still further soaking. At the other end of this tunnel the sheep is held by a man under a very strong shoot of water forced through a pipe, by means of which the cleansing process is completed. In a few days the sheep is again dry and can be shorn. All these methods, however, have the defect of losing the yolk; but when it is remembered that in order to wash, say, 1,000 sheep and preserve the dirty water so that either it might be spread upon the fields or the potash and grease be extracted from it, a number of tanks and other appliances would be needed, it seems rather doubtful whether the saving would pay. Nevertheless, the waste of the present system is undeniable.

**27. Advantages and Disadvantages of Washing Sheep.**—It may be asked, Why should the farmer wash his sheep at all? why not send the fleeces unwashed always, as many do from Australia and elsewhere? The advantages of sheep-washing are: (1) That if it is well done the colour of the wool is improved, whereas if not done at all, the wool, if it lies long after shearing, may become a little stained with the grease, and so always have a yellow tinge. (2) If the washed wool is one-third of the original weight of the fleece, then two-thirds being washed away, there should be a proportionate saving in the cost of carriage, which, from Australia, is a large item. (3) When the manufacturer sees the wool

washed, he can value it more exactly, knowing from experience what it will yield; but with unwashed wool it is exceedingly difficult to estimate correctly what the result will be. To set against these advantages there are two serious drawbacks. (1) Wool washed before shearing is not always so soft as that with the yolk left on it, because when the oil is all washed out, the horny nature of the wool causes it to get hard, and to lose its silky feeling. (2) The manufacturer loses the benefit of the potash, &c., in the yolk, which he can extract from the dirty soap-suds, and thus one of his sources of income—though a small one—is diminished. The advantages and disadvantages to the manufacturer are, perhaps, pretty evenly balanced, but the total loss to the farmer of good fertilising manure is undoubted, and much to be regretted.

28. **Adulterated Soap.**—The chief requisite for the manufacturer in wool-making is to have a soap which will clean the wool perfectly without injuring the fibre, and which at the same time is cheap and unadulterated. There is nothing which is more easy to adulterate than soap, and nothing in which detection is more difficult. The injury done to woollen goods by impure soap is great, especially when they have to be dyed a delicate colour. For instance, a yellow singed appearance is given by using soap with much resin, or much alkali; the fibre of the wool can also be burnt if the soap is too strong, especially if the water be very hot. But apart from injury to the wool, the loss in money is great if a soap is made up with silicate of soda, and of potash, resin, potato-starch, and water. Common salt, too, is often mixed with soda-ash used in soap, and even earthy matter is put into it to give weight. A receipt for testing soap is to dissolve one ounce of soap in a given quantity of water; put it into a long test glass, and add a quarter of an ounce of diluted sulphuric acid, or less. The acid neutralises the alkali; the grease and resin, if any, float on the top, and the earthy matter falls to the bottom;

It is a mistake to suppose that soft soap necessarily contains more water than hard soap. The reverse may easily be the case. Soda soaps are hard, potash soaps are soft, because it is the nature of these materials to make soaps, of which they are leading constituents, hard and soft respectively. But as a soda soap will take up four times as much water as a potash soap, and still remain firm, the temptation to adulterate in this way is great. Some soda is often put into professedly potash soaps just because it will hold so much water.

29. **Effect of Hard Water.**—If washing or dyeing is to be well done, the water must be soft. The two chief causes of hardness in water are carbonate of lime and sulphate of lime. The former can be precipitated by boiling the water, but as this is too costly where water is used in great quantities, it is never done. The effect of hard water is well stated by the *Textile Manufacturer* :—“When hard water is used for dyeing or cleaning purposes, without being previously softened, the lime it contains, in many cases, destroys and precipitates the dye-stuff, and in all cases immediately attacks and decomposes the soap used. The alkali in the soap, that is to say, the soda or potash with which the soap is made, leaves the oil and tallow with which it has been combined (forming the soap) and unites itself with the carbonic and sulphuric acids contained in the carbonates and sulphates of lime. The lime thus thrown out of combination with the sulphuric and carbonic acids immediately unites with the oil and tallow, forming what is called an insoluble lime soap—a pasty greasy substance, which has no washing properties whatever. This is deposited on the fibre of the wool or textile fabric undergoing the scouring operation, and renders the dirt or grease upon them far more difficult to remove. This insoluble lime soap has often a most disastrous effect on goods which subsequently have to be dyed, causing spots and uneven dyeing, owing to the insoluble lime soap sticking to the fibre of the fabric, and in many



cases being only partially removed by subsequent scouring."

It is clear that the soap can have no effect on the wool till the lime in the water has finished its work, and is entirely united with the alkali of the soap. Then the washing begins, but now the soap has to wash out not only the original dirt from the wool, but also the insoluble lime soap which has settled on it; thus making for itself, as it were, work to do.

**30. Means for softening Water.**—The lime, therefore, should previously be removed by some other means. Soda crystals, or soda-ash, are often used, but as they are carbonates of soda, that is, are already in combination with carbonic acid, they cannot do the work so quickly or so well as soda in a free state. They also require the water to be heated. Caustic soda is the best material to use, but only when it is pure and unadulterated with common salt, which makes water hard. Powdered caustic soda, which can be obtained pure and cheap, is everything that is needed. A quarter of an ounce per gallon is enough for the hardest water, while a quarter of that—one sixteenth of an ounce—is enough for average water, or 4 lbs. per 1,000 gallons. It acts equally well when the water is cold, and, rendering the lime insoluble, precipitates it along with any iron or magnesia salts that the water may contain. It should, of course, be put in before the soap, or the benefit is lost. The requisite quantity of caustic soda for any given water can be easily found by taking one gallon of water, and adding the soda till all the lime is precipitated. The water should be boiled at each test to aid precipitation, and when it becomes quite clear after cooling, it will be found that all the lime has been precipitated.

**31. Receipts for Soap.**—Having obtained good water, suitable soap must be used. Some persons for strong wools use soda alone; but nothing could be worse, as it makes the wool yellow, hard, and brittle. Another method adopted for greasy wool is to steep it in clean

warm water, constantly running, for some time before washing it with soap, in order to remove the grease, and so save the soap. This is a mistake; it is well, no doubt, to remove the earthy matter in that or any other way, but this cannot be done without also removing the grease or yolk, which contains so much potash, and which actually helps the soap to wash. The old-fashioned way of washing in the woollen districts was to make a lye or wash of stale urine and alkali. The former was useful, because it contained carbonate of ammonia, and the organic matters were thought serviceable in preventing the alkalies from injuring the wool fibres. This, however, has now gone out of use, and soaps are employed instead. As has already been said, potash, and not soda, should be used for wool-washing. Yolk consists of carbonate of potash to the extent of nearly half its weight, and is the means of keeping the wool soft and silky. Nature in this matter is a sure guide, and experience shows that potash both lubricates and bleaches the wool, while soda has just the opposite effect, making it hard and yellow. The chief makers of pure caustic potash are the Green Bank Alkali Company, Limited, of St. Helens, who give the following receipt as the best they know for good soap:—"Take 50 lbs. of Green Bank pure caustic potash; put it in any iron or earthenware vessel with 9 gallons (90 lbs.) of water. Stir it once or twice; it will dissolve immediately and become quite hot. Let it stand till the lye thus made is cold. Place in any convenient vessel for mixing 20 gallons of cotton-seed oil and 20 lbs. of clean melted tallow. Pour the lye into the oil in a small stream, at the same time stirring with a flat wooden stirrer about three inches broad. Continue gently stirring until the lye and oil are thoroughly combined and in appearance like honey. Cover the vessel up, and put it in a warm place for a day. Stir it up again well, and leave it for a few days, and the saponification will be complete, and 340 lbs. of soap will be the result." This is for a fine scouring soap. If it is wanted

stronger, a little pearl-ash can be added, or the oil reduced, say from 20 to 18 gallons. For very greasy wool it should be stronger still. This is the cold-water process, no boiling being needed. If boiled the soap is made more quickly, the method recommended being to take 18 gallons of oil and 18 lbs. of tallow; boil them with 21 gallons of caustic potash lye of 18 degrees Baume. Then add  $7\frac{1}{2}$  gallons more lye of double the strength, and about 6 lbs. of pearl-ash, to prevent stringiness; continue boiling, and the soap will almost immediately be made.

**32. Danger of Strong Soap and Hot Water.**—An indefinite number of receipts could be given for soap equally simple with these, but they are not necessary. The chief point to be observed is that for finishing and sizing goods or yarn a neutral soap should be used; that is, one in which the alkali and oil balance each other; but for wool-washing there should be a slight excess of alkali, depending on the grease and dirt in the wool; but, above all things, there should not be too much, or the wool will be burnt. Nor should the water be too hot. Any heat which the hand cannot bear is too great, but dirty wool naturally requires more heat than clean, and therefore no exact degree can be given. It is so easy to make soap, and the risk in buying it is so great, that it is surprising that all manufacturers do not make it for themselves. It is a usual and desirable thing, when the wool goes through three or four washing bowls, to put a much stronger soap in the first than in the others, in order to extract at once the dirt and grease. In the last bowl, on the other hand, a soap is used in which the oil is in excess of the alkali, so that the wool is fed and softened before it is dried. When it is remembered that the little cells which compose the fibres of wool are swollen and raised by the heat of the water, and the wool itself actually softened, it is easy to see that a good oily soap will be able to penetrate the fibre, and, by depositing some of the oil upon it, will make it softer to work in the future processes. Some persons also finish with putting

the wool through a bowl of clean water, but though this may improve the colour, it prevents any oil from being left in the fibre, and this is not always desirable. It is a fact, not generally appreciated by wool-washers, that wool can be dissolved altogether till nothing is left visible. Hot water alone will not do this, wool may be boiled without being dissolved; but put a little caustic potash, or anything of a similar nature, into the water, even if it be very far from boiling, and the wool will rapidly disappear; the hotter the water the quicker it will melt. This shows the danger of having too strong a soap, and also too hot water, for even if every fibre merely lose the smallest fraction of its surface, the total loss is great. And besides, it will be the serrated points which will go first, and thus the spinning properties will be spoilt. Very hot water alone, even without any soap, spoils the wool, by taking out its natural curl, and thus destroying its spinning power, and many a bad spin is due to nothing more than the excessive heat of the sud in which the wool has been washed. No one can estimate the amount of loss caused by these two evils—too strong soap and too hot water; and they should be carefully watched by the person in charge.

For washing mohair some persons use only cold water, thinking it better not even to wash the fibres thoroughly. They cannot stand as much washing as wool certainly, nor can alpaca, but the experience of the trade generally does not favour cold-water washing, but rather a moderately good washing in a warm sud, with a neutral soap, and not too much of it.

**33. Petrie's Washing-Bowl.**—A short description of the washing-bowl, and of the principles on which it works, is now necessary. Formerly all washing was done by hand. The bowl was filled with the sud, and the wool put into it, while one or two men with wooden poles stirred it about, and finally lifted it on to a travelling apron which carried it between a pair of rollers, by which the water was squeezed out. The same principle still pre-

vails, but machinery does the work. In Fig. 3 is represented one of the best forms of washing-bowl made by Mr. John Petrie, of Rochdale. The wool is placed on a "feeding-apron," A, and carried down into the water by a brass roller, B; four forks, F F, gradually carry the wool forward through the sud, and through three stationary forks, C, which are fixed in the water. It then arrives at a lifter, L, which raises it from the water to the rollers, R R, which squeeze the water out, and as soon as it has passed through them it is shaken and opened by a wooden roller made like a fan, and then thrown on to the floor. The action of the lifter L is the chief peculiarity of this bowl; it is the entire width of the bowl, and is made by placing side by side a number of bars of wood. Into these bars spikes are inserted, sloping upwards, and towards the rollers. These bars have a short stroke motion; every alternate one moves up a few inches, while the other set of alternate ones move down; at the next stroke those which moved

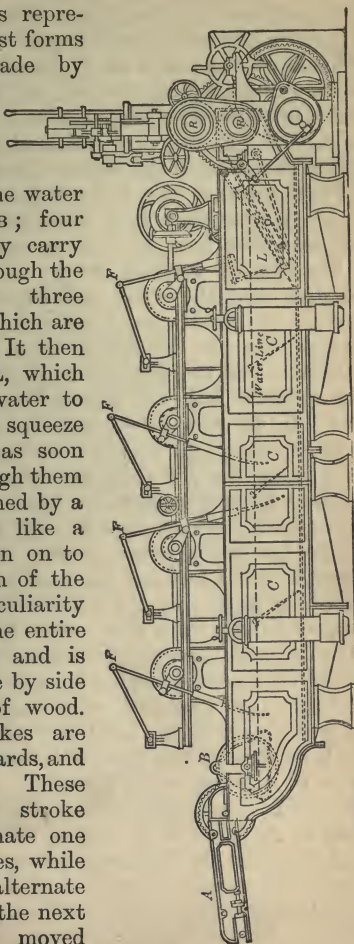

down now move up, and those which moved up now move down, and so on, turn about. By this motion the wool on them is gradually carried up to the rollers, and so out of the bowl. As each set of bars moves down, the wool on them is caught by the set that moves up, and at each stroke is thus raised about three inches till it reaches the rollers. As the wool is floated gently on to the bottom of the lifter in the water, it never goes up in lumps, and thus passes evenly through the rollers.

**34. McNaught's and Jefferson's Bowls.**—This improvement has been effected in consequence of a change in the idea of washing wool. It was thought a good thing to swill the wool well, to rinse it out by quick stirring, and finally to give it one rather rapid passage through the sud by means of a fork which lifted it entirely out of the water, high up, on to an apron, which took it to the rollers. It is now seen that this is a mistake. If wool is drawn rapidly through the water it clogs together and becomes stringy, and in doing so binds in all the dirt that may be attached to it. But if the wool floats gently on the water, its natural tendency is to spread out very openly, and thus make all the dirt and foreign matter separate from it and sink. Hence it is seen that the forks of the bowl must move very slowly indeed, so as to give the wool rather the appearance of floating quietly on a slow current, rather than that of being dragged through the water by rods. An exceedingly good machine has been made by Messrs. J. and W. McNaught, of Rochdale, to accomplish this. Instead of the forks moving one after the other through the water and thus swilling the wool, they have fixed all their forks to an iron frame which hangs by chains entirely above the bowl. By means of an eccentric wheel it drops down to the level of the water, moves very slowly along with the forks in the water, which gradually propel the wool in the gentlest way, and then it is lifted up again, moved backwards to its starting-point, and again descends. In this bowl, too, the rollers are at the water's

edge, so that the wool does not need to be raised out of it. But this principle is carried out with greatest success by Messrs. Jefferson Brothers, of Bradford, whose squeezing rollers are illustrated in Fig. 4.

The lowest rollers, c c, have their nip below the level of the suds, D. The wool, therefore, which floats up to it, and is also pushed forward by the fork, A, is caught by the nip while still loose and floating freely in the water, and before it has any opportunity of becoming compact and stringy. As soon as it passes through the nip of c c, it comes again into the sud, and is quite saturated

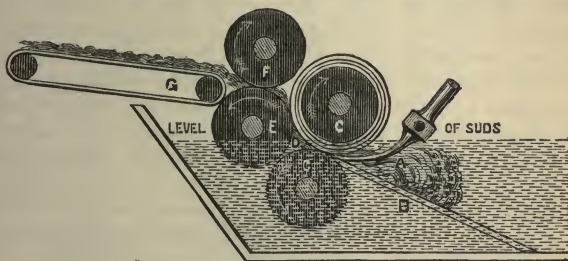

Fig. 4.

before reaching the second nip, E C, which squeezes it a second time and passes it on to the third rollers, E F, for a final wringing, and so on along the apron G into a box ready to receive it.\* This method avoids many difficulties which the washer of long wool encounters with other machines, such as the wool forming into lumps and choking the rollers, or falling back off the apron into the sud. It undoubtedly enables the wool to be squeezed more evenly, and while more spread out, a much better colour is also obtained, with a great saving of soap.

35. **Dr. Braun's Machine.**—There is another method

\* The top roller, F, is often made as a beater or fan to shake the wool instead of squeezing it, and so make it lie lighter and looser on the drier. This is found to be an improvement.

of wool-washing—invented by Dr. Braun, a German, and tried in Verviers—which has probably not been tried in England, but which is here given on account of the remarkable results which are said to have attended it. Though the process itself is evidently complicated and clumsy, it is worth the attention of wool-washers who may be able to bring it into practical use. The description is quoted from the *Textile Manufacturer* :—

“This apparatus is designed for a new method of cleansing wool, consisting in washing the raw material first with water, then with alcohol and ether, and again with water. By the use of the apparatus the proceeds of the washing are not lost, but can easily be recovered and utilised, while the alcohol and ether are used continuously and with but little diminution. The apparatus (Fig. 5) consists of a vessel, A, by preference made cylindrical, containing a well-closing lid; above this vessel are three other vessels, B, C, D, situated at a higher level; and on the same level as A is a distilling vessel, E, with cooling-pipes situated above the receptacles B, C, D. The different vessels are connected by pipes, in the manner shown, and the process is carried out in the following way, viz. : B is filled with water, C with alcohol (of sixty per cent.), D with ether, whilst A contains the wool to be cleaned, which latter is compressed between two frames containing sieves or perforated plates; all cocks having been closed, those marked 7, 1, 6 are opened first; thus the water passes from B into A from below, and expels the air from between the wool. As soon as the water passes out of the cock, 6, the two cocks 6 and 1 are closed, and 2 and 5 opened, until the water passing out of 5 is quite clean; cock 7 is then closed, to stop the flow of the water, and 8 opened to admit alcohol, until cock 11 shows alcohol; cocks 8 and 5 are then closed to stop the flow of alcohol, and 4 and 9 opened, cock 2 being still open, which admits ether; the latter then, with the assistance of the alcohol, drives out the water which is still in the lower portion of the wool, and into the vessel,



E. When the first portions of ether have expelled the alcohol, the remaining portion will commence to dissolve the grease in the wool, and carry it into E. As soon as the fat has been removed, the cocks 4, 2, and 9 are closed, and 8, 1, and 3 opened, until the cock 11 shows alcohol; cock 8 is then closed, and 7 opened, which causes the alcohol which is in the lower part of the wool

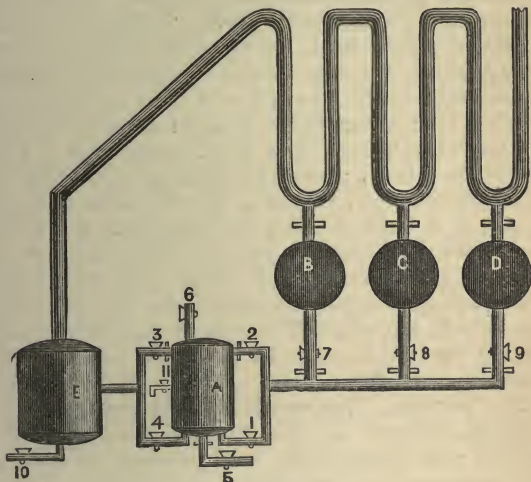

Fig. 5.

to carry any remaining ether into the vessel, E. As soon as all ether and alcohol are removed from A, the cocks 7, 1, and 3 are closed, and 6 opened. The wool, now free from grease, alcohol, and ether, is taken out of the vessel A, and washed with tepid water, while A can be filled with a fresh portion of material to be operated upon. The vessel E now contains water, alcohol, ether, and fat, which substances may be distilled in different ways. The fat and the greater portion of the water are drawn off by means of the cock 10; the distilled ether collects

in D, the alcohol in C, and a part of the water in B; the alcohol and ether are almost completely recovered; the loss of water is easily replaced. The arrangement may be varied by having several vessels, E, and using each of them for a separate liquid. The inventor claims greater efficiency than by the usual mode of washing, and maintains that the wool is preserved in a better condition, which latter assertion seems to have been borne out by some experiments made at Verviers, in Belgium. A lot of Buenos Ayres wool having been divided into two portions, A and B, A was washed by the above described process, and B in the usual manner. The results were the following, viz.: A was whiter than B: A lost in burring 6 per cent., while B lost 13 per cent.: In spinning A, 41 out of 1,440 ends broke; while in spinning B, 100 broke out of the same number: Out of A, 22,000 yards were spun, but out of B, only 20,000; the yarn spun out of A is softer, more elastic, more regular, stronger, and more even in colour after dyeing, and winds very much easier. If the method we have described has all the advantages which are claimed for it, it proves again that scientific treatment is superior to the old way of working by rule of thumb."

36. **Verviers Wool-washing.**—So much has been heard in England of the superior wool-washing in Verviers, that the following brief account, given by Mr. Craig-Brown to the South of Scotland Chamber of Commerce, of the washing in the great mill of Messrs. Peltzer & Son, is of value. They are spinners of worsted and woollen yarn made of Buenos Ayres and Monte Videan greasy wool, and very largely supply the Glasgow market: "Having been sorted, the wool is put into an iron cage mounted on a swivel in front of the first scouring-trough. Here it is saturated from an over-head pipe with a liquor made from the drippings of previous cagefuls of greasy wool treated with alkali. Pipes carry the drippings into a large tank, where the alkali is added, and the contents pumped high enough to permit of redistribution. This

liquor has a remarkable effect in loosening and opening the wool, a process further stimulated in the cage by showers of pure cold water. From this cage the wool is fed into the first tank of the scouring machine; the liquor is the same as with us—soda and hot water. But a feature of the process is the extreme slowness with which the first forks travel—an unquestionable advantage. After being thoroughly raised, or freed from grease, the wool is carried into the rinsing-troughs. These are of great capacity, are kept constantly supplied with a large stream of clean cold water, and have forks travelling at a velocity as much above ours as the forks in the hot tanks are below it, the object of which is obvious. By this radical cleansing the soda is completely removed, instead of being left to eat into and discolour the staple in the process of drying. Most of the wool is 'whizzed' after drying, but I saw one drying-machine fed continually from the scourer, and delivering wool in that nice soft condition—neither too dry nor too moist—which ought to be the aim of every scourer. It was a large hollow chamber, through which the wool slowly passed on an apron, subject to a strong draught of heated air drawn through it by an exhaust fan." It is worth noting here that the scouring property of the potash in the yolk from the fleece is recognised by its being used over and over again to partially wash the new wool, and also that though soda is used for scouring, the wool is well rinsed in clean water lest it should discolour and harden the wool. As much of this wool is dyed before spinning, it is necessary to extract all the oil from the fleece, but potash would do this as well without the danger of spoiling the colour.

**37. Ordinary Hot Blast Drying Machine.**—Having washed the wool, it is necessary to dry it. The common form of dryer is a large flat or sloping table covered with wire netting, and with wooden sides. Underneath is a number of hot steam-pipes, and at one end is a circular fan which revolves at a great speed, making

often 800 or 900 revolutions per minute. The wool is spread on the top of the netting, and the fan blows air heated by the steam-pipes through it, and thus it is dried. Sometimes the pipes are above the dryer, which is then in a small room by itself, and the fan draws the hot air down through the wool; but this mode is much longer and therefore more costly than the former, in which the wool is always being blown up from the wire netting, and so lies loosely and lightly. In the latter way the draught forces the wool down on to the netting and makes it lie dead and heavy, so that the air cannot get through it so well. The fault of both dryers is that they take up a great deal of room, and are difficult to cover evenly. Consequently if any thin place is left, the air blows up or down through it, making the wool there too dry, and leaving any thick place too wet. There is a risk also of the wool being allowed to remain too long on the dryer, in which case, owing to the hot pipes, it becomes scorched; or it may be taken off too soon and is thus difficult to work in the next machines. Some more regular method is therefore needed to ensure a uniform amount of moisture, and this seems to have been effected by Mr. Petrie, of Rochdale.

38. **Petrie's Dryer.**—Fig. 6 represents one of these machines, 28 feet long, 7 feet 6 inches wide, and 10 feet high over all. The wool is fed in at the side as marked, and passes through, forwards and back again, in the direction of the arrows till it is delivered at the opposite side from that at which it entered, and at the bottom. It rests upon tables which are made of bars lying side by side. Every alternate bar is stationary, the others being movable but fastened together underneath. The set of movable bars have a motion forwards and backwards, but when moving forwards they are *above* the level of the fixed bars, thus propelling the wool forwards with themselves. But when they travel backwards again, they drop down to *below* the level of the fixed bars, and thus do not take the wool back with them.

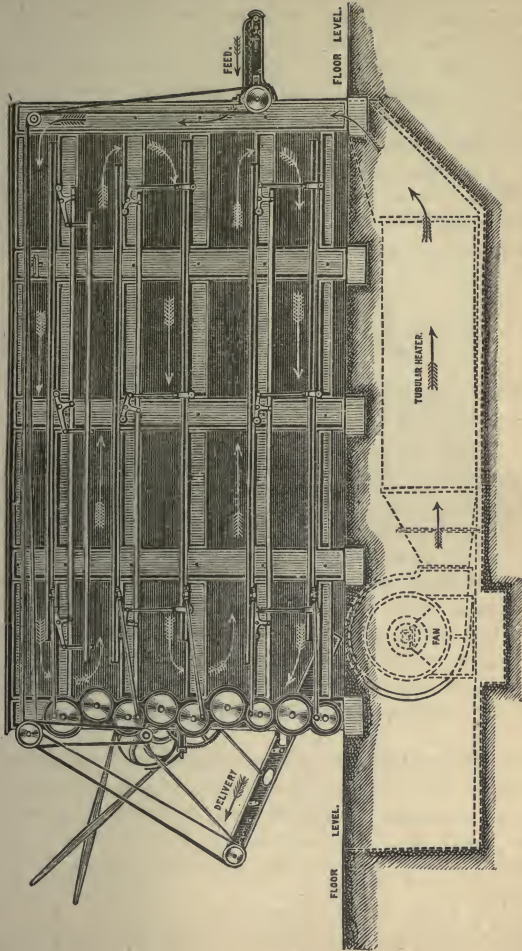

Fig. 6.

This motion is obtained by the levers and rods fixed to wheels at the front of the machine, as shown in the diagram. As the wool on the top table comes to the end, it falls over on to the next lower, and the same process is repeated. There is a hot blast blowing in the same direction as the wool travels, and this both lightens it and helps it on. It also lifts the wool from the feeding place to the top table, for the entire draught passes the mouth of the opening where the wool goes in. This machine appears to be suitable for every kind of wool. It is applicable to carbonising wool and rags. It is also

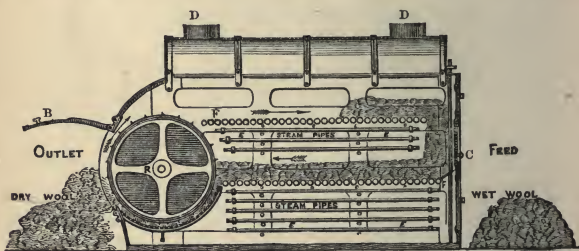

Fig. 7.

used in drying cotton and other fibres. Its production of dry wool is great, for it is said to be able to dry 80 to 90 packs per week, which is much more than an ordinary open drier of the same size could do. It also makes the wool of uniform dryness, for the time taken by the wool in passing through is regulated by the dryness required.

39. **Moore's Dryer.**—There is another dryer, however, known as Moore's, of Trowbridge, which is extensively used by woollen manufacturers, and which is simpler than Petrie's. As shown in Fig. 7 the machine consists mainly of two sets of small rollers, F F, and a large spoked drum, R. The wool, about 100 lbs. at a time, is fed in at c, where there is a door. The lower set of rollers F revolve towards the drum, and carry the

wool along on the top. They are made of iron tubes  $3\frac{1}{2}$  inches in diameter, and fit close together so that no wool can fall, but yet they allow dust and dirt to pass through. The drum is constantly revolving at about 110 revolutions per minute, and as the wool reaches it, the spikes carry it round and up to the top set of rollers, the door, B, being then closed. The top rollers, F, revolve towards the right, and carry the wool to the other end, when it drops down and begins the journey again. There

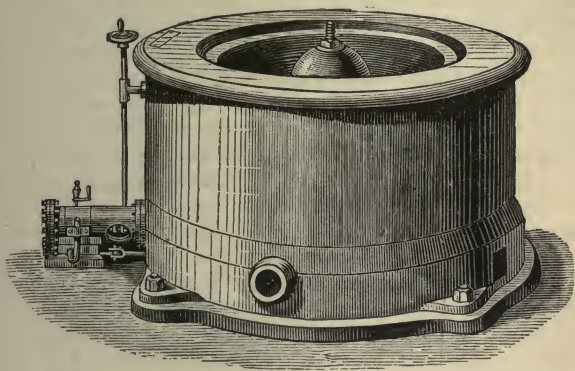

Fig. 8.

are hot steam-pipes below each set of rollers, and the pipes themselves soon become hot. D D are two chimneys for letting out the hot damp air; fresh air passes in under the lower set of pipes, E. The machine will dry from 1,500 to 2,000 lbs. per day. It has the great advantage of being without a fan, which costs much to drive and blows away hot air long before the heat has done its proper amount of work in drying. When the door, B, is opened the wool is thrown out without any labour.

40. Hydro-extractor.—Where it is possible, it is better to dry without heat at all, simply with a cold

blast, because however heat is regulated it is apt to dry the wool too quickly, and so to shrink it and make it hard. Every one knows that in drying flannel, it should be hung in the open air to dry slowly, and not held before a fire or put in a hot place. The same thing, and for the same reason, applies to wool. There is another form of dryer called the hydro-extractor, which is sometimes used for wool, but chiefly for yarn and cloth, but it does not make them entirely dry. The material is put inside the wire circular cage shown in the centre of Fig. 8, which revolves at an immense speed inside the iron case which is seen outside. It is worked by the engine at its side. The centrifugal force and the current of air drive the water out through the sides of the wire cage against the inner sides of the iron case, which is stationary, and it there escapes from a pipe at the side.

41. **Oiling Wool.**—The question of oiling wool is one of importance and interest to the manufacturer, and it is necessary he should use such oils as are best suited to his purpose, if he use any at all. For long English wool, unless it is spun to its farthest limit, oil is really unnecessary either for combing or spinning, but there is no doubt it softens the wool and helps it to spin to a higher count than it would reach if quite dry. But there is another reason why it is liked. It is much cheaper than wool, the very best olive oil being only from 5d. to 6d. a pound, while combed wool is cheap when three times that value. Every pound of oil used, therefore, represents a distinct gain to the manufacturer. The French worsted spinners, as is well known, spin without oil, and even when they use it in carding and combing their short Botany wool, they wash it all out before beginning the process of drawing preparatory to spinning. They do this from the belief that the cloth can be dyed a brighter and clearer colour when the wool has been worked free from oil and perfectly clean. Some English worsted spinners and manufacturers have adopted the same course, and it is obvious that their



customers who scour or dye their yarn or cloth will prefer it free from oil, if for no other reason than that it will lose less weight in those processes when free from, than when mixed with oil.

**42. Best Oil to be Used.**—If, however, oil is used for worsted yarns, it should be the best quality of olive. Gallipoli is the name for the very best, but some others are so good as to be hardly distinguishable from it. Olive oil softens the wool, and even after a year or more the wool does not become hard or stiff, and the oil keeps fresh and sweet in it. The loss which may be occasioned by oil turning rancid or sticky on yarn which has been kept in stock for a year is so great that no prudent manufacturer will run any risk; but, at the same time, it is most difficult for any one but an expert to detect adulteration in oil, cotton-seed oil being largely used for adulterating it; and therefore it should only be bought from merchants whose character for honesty can be relied on. A compound known as “soap cream” has been introduced, with the recommendation that it is cheaper and better than oil, improving the colour of the wool, and helping the process of scouring the yarn or cloth afterwards. As, however, it is largely composed of water, its cheapness is not surprising, and its other supposed virtues are very doubtful. The chief result of employing it is that less oil is used than when an equal quantity of real Gallipoli is put on to the wool, and any one who wishes to arrive at this result had better simply put on half the quantity of Gallipoli and add what quantity of water and soap he thinks fit.

**43. Oleine Oil for Woollens.**—For woollen yarns, especially those containing much mungo and shoddy, oil seems necessary as the fibre is very short. But as it is all washed out again before or during the milling process, it is not requisite to use anything so expensive as olive, and oleine oil is therefore generally employed. It is obtained from the manufacture of stearine candles. When the stearine is extracted oleic acid is left, but is

mixed with sulphuric acid, which has been used to separate the stearine from it. From the oleic acid, oleine is obtained, but the sulphuric acid must be separated from it by distillation. As it is heavier than the oleine, part of it is often left in to cheapen the oil ; but this form of adulteration is very injurious, both to the wool on which the oil is used and to the persons working with it. Impure oleine prevents the cloth from dyeing a good colour and makes it streaky ; but the pure oil is really of assistance in helping the scouring of the cloth. One of its properties is the great readiness with which it saponifies, on account of which it is largely employed in soap works. When, therefore, it has been used on the wool, it is only necessary to put soda or potash into the water for scouring the cloth. The oil comes out of its own accord, and unites with the soda or potash to form soap, and thus scours the cloth. If olive oil has been used on the wool, some soap is needed for scouring. Where woollen yarns, previously oiled with oleine, have to be scoured, it is only necessary to put ammonia into the water, for, being looser, they give out their oil more readily than does cloth.

**44. Test for Oil.**—The best oils are those which oxidise least, remain fluid longest, and saponify with the greatest facility with carbonate of soda without the addition of heat. The power of remaining fresh and unrancid is also of prime importance, and in this olive is pre-eminent. The following receipt is given for testing oil. Take a portion of oil and stir it up with forty parts of a solution of carbonate of soda of three degrees Baumé. If the oil forms a milky emulsion, without any oily drops on the surface, it is a guarantee for a good greasing of the wool.

**45. Quantity to be Used.**—For worsted yarns the less oil that is used the better ; three pints per pack (240 lbs.) is quite enough for ordinary English wool. Very strong wool needs more, and absorbs it without showing that much has been used. For woollen yarns the following are very common quantities where the fibre

is short and shoddy largely used. When the yarn is sold in the grease, for every 100 lbs. of wool 18 lbs. of oleine and 30 lbs. of water are mixed with it. Where the yarn is sold scoured, 12 per cent. of oleine and 30 per cent. of water are considered enough. The water should be hot and mixed with the oleine, a little sal ammoniac being used to help the assimilation. In making vigogne or angola yarns, which are mixtures of cotton and wool, the wool must be well mixed with the above proportions of oil and water before the cotton is put to it; otherwise the yarn will not be regular.

46. **Carbonisation.**—The subject of carbonisation may be dealt with here, as it comes under the description of washing. All wool before being sorted contains much vegetable matter in the shape of seeds, grass, moss, burrs, and such things. Most of these can be taken out in the sorting, or fall out in the carding and combing, but some of them, especially burrs, cling so tenaciously to the fibre that they are carried through every process into the cloth. Among the worst classes of wool, in this respect, are Port Philip, Cape, and Buenos Ayres; they are often literally one mass of burrs. To pick them out by hand is impracticable, while if the wool is carded with them in, though some may be knocked out by burring rollers and other machines for the purpose, a great number are opened, and laid lengthways along the fibre, in form resembling a small centipede, and in this state adhere more firmly than before to the wool. The only effectual method of removing them is by carbonisation. Sometimes this is done to the wool immediately after washing; at others it is done to the cloth before or after milling. The process is generally called carbonisation of wool or cloth, but it is not the wool which is carbonised, but the vegetable matter adhering to it. The effect is to reduce the vegetable fibre to cinders or dust, so that it will fall out when the material is washed or shaken.

47. **Methods employed.**—There are two methods most commonly employed for doing this. The one is to

saturate the wool with dilute sulphuric acid of 4 to 5 degrees Baumé, which is afterwards removed by "whizzing" the wool in a circular hydro-extractor. The wool is then spread out in a room heated to 250° Fahr., in order that it may dry quickly. The air being so hot absorbs the moisture very rapidly, leaving the acid in the wool. The acid, which has a strong affinity for water, lays hold of the burrs and other vegetable matters which still retain moisture, and extracts it from them, leaving only the cinders, which are little else but carbon, and which crumble away when the wool is afterwards washed. In extracting this moisture, however, the sulphuric acid is decomposed; and if any is left, it is so little as to do no harm to the fibre of the wool, especially as the wool is immediately washed. The other method is known as Joly's process, from the name of its inventor, a Frenchman. By it the wool is saturated with a solution of chloride of aluminium of 6 to 7 degrees of strength Baumé, about 8 to 10 lbs. of chloride being used to 16 lbs. of wool. The wool is then whizzed in a hydro-extractor, and well dried in the ordinary way. After it is quite dry, it is taken to the carbonising room, which is heated to 212° Fahr. and left there for three-quarters of an hour. It is then washed with water and fuller's earth, by which all the chloride is removed, and the carbonised vegetable matter washed away. This method is the one generally adopted now, as it is simplest and safest for the wool, and at the same time attended with least inconvenience to the workmen.

Carbonisation can also be effected by the fumes of muriatic acid. The wool is placed on hurdles in an airtight room, and exposed to its action for three or four hours, after which the temperature is raised to 212° or more. In a short time the heat is stopped, fresh air is let in, and the wool, when cool, is washed. The wool before being fumigated must be almost, but not quite, dry.

48. **Wool not injured if care be taken.**—Before treating wool in any of these ways it is necessary to have it thoroughly washed, so as to remove every particle of grease. If this be not done, the result will be that the wool will be made tender, and cannot be milled, while it will not dye well. Experiments have been made to test this, and it has been found that “the sulphuric acid, acting on imperfectly-cleansed wool, sets at liberty the fatty acids of the grease, which fix themselves on the wool, and cannot be got rid of by the ordinary processes.” In addition to this, the grease that remains clogs the saw-like edges of the wool, gluing down the points of the serratures, thus making the edges smooth and unable to felt; and the fibres themselves are considerably weakened, so that on being milled they do not form a compact mass, but are liable to be torn or worked into holes. Where, however, the wool has been perfectly washed before being treated with the acids, no injury whatever is done to it; provided, of course, that the carbonising is effected properly, and that the whizzing in the hydro-extractor is sufficient. Wool washed in the usual way, and wool washed and carbonised, have been microscopically examined, and the scales and serrations of the latter have been found to be just as clear and perfect as those of the former. Strange to say, the strength of the fibre in the latter case is even increased. Herr Weisner, of Vienna, tested horse-hair and the hair of the Angora goat, and found that when the acid did not exceed 4 per cent., or the heat  $60^{\circ}$  to  $65^{\circ}$  C., fibres which previously had broken with a weight of 480 grs., now only broke with 568 grs. When the acid was raised to over 7 per cent. the fibre was weakened. Though wool will not bear an equally strong acid, yet if treated in proportion, its strength is not injured.

49. **Wiesner's Experiments.**—The following description of Herr Wiesner's experiments is worth reproducing here, as showing the different ways in which wool must be treated according to the character of the vegetable matter

which it is desired to carbonise. After examining many kinds of wool, he found that the vegetable matter might be divided as follows:—1. Burrs of various kinds. 2. Fragments of straw and grass. 3. Raw textile fibres, such as jute. 4. Fragments of leaves, &c. 5. Dung, which was composed of pure woody or cuticular cellulose. Now there are three kinds of cellulose. It exists in a state of almost absolute purity in the bark and pith of the impurities in the wool, and in the dung. The solid cellular tissue in all vegetable matter consists principally of ligneous cellulose, and the cuticular cellulose is found in the rind of fruit, leaves, and stems.

“In his experiments,” says the *Textile Manufacturer*, “Herr Wiesner employed for pure cellulose, Swedish filtering-paper; for ligneous cellulose, jute and thin pine-wood shavings; and for cuticular cellulose, raw cotton. These substances were plunged into the sulphuric acid solution of given strength, left there for about a quarter of an hour at the temperature of the atmosphere, pressed carefully between sheets of filtering-paper, and then submitted to the action of a certain degree of heat. With an amount of acid equal to one or two per cent., and a temperature of 40° to 50° C., the ligneous fibres, at the end of three-quarters of an hour or an hour, became brittle, and brownish in colour, and at 55° they were carbonised. Pure cellulose presented rather more power of resistance; with 1 to 2 per cent. of acid it became brittle at the end of about an hour at 50° to 55°, it began to turn brown at 60°, and to blacken at about 65°; cotton did not become brittle till the heat was 60° to 62°, began to turn brown at 70° to 72°, and did not carbonise until the temperature reached several degrees higher. With a more concentrated solution, and greater heat, the decomposition of the three kinds was more rapid, but the differences remained the same between them. Before any signs of decomposition appeared the fibres all became so brittle that the slightest pressure reduced

them to powder; it is therefore evidently unnecessary to burn or carbonise vegetable matter to purify wool from it. Vegetable substances, in carbonising, give out a smell of caramel, burnt sugar; the carbonised matter contains a brownish substance, soluble in water."

Thus it is seen that these vegetable substances can be removed from wool in an hour by employing 2 to 3 per cent. of sulphuric acid, and a temperature of  $50^{\circ}$  to  $60^{\circ}$  C. This is a matter which deserves much more attention from English manufacturers than it receives, especially in the worsted trade. Woollen manufacturers who make shoddy by extracting the wool from rags which have cotton in them are, of course, familiar with it. As is often the case, the warp may be cotton and the weft worsted, or *vice versa*, and the rags are then treated as above described, till only the wool is left. It is then worked up into shoddy, and mixed with more wool, to be again spun into yarn, and woven into cloth.

50. **Extraction of Oil from Soap-suds.**—A few words should be said regarding the extraction of oil from the refuse soap-suds, though this is not the place to describe all the chemical operations. The saving is so great, however, that no wool-washer ought to allow his suds to run away in the form they leave the bowls. Tanks are prepared to receive the suds, and when a tank is full, a certain quantity of vitriol is poured into it. This causes the sud to curd or crack, and the grease and all solid matter fall to the bottom, leaving the water comparatively clear. This water is then run off down the drain, and the thicker portion at the bottom is afterwards run into a filter-bed of sand and gravel, through which the rest of the water gradually filters, leaving the solid and greasy matter behind. This is laid in cloths and called "puddings," which are pressed in hydraulic or steam presses till all the oil is squeezed out. From what is left, potash and other ingredients can be extracted, and the refuse is used as manure. The oil must be purified, and can then be used with great advantage for soap-

making or lubricating. As it is not worth while for each wool-washer to do this for himself, it is usual to sell the suds to extractors, whose business it is to carry out this operation. The price is, of course, clear gain to the washer, and the process has, at times, been very profitable also to the extractor, especially when much greasy Colonial wool is used.

---

## CHAPTER IV.

### THE DIFFERENCE BETWEEN WORSTED AND WOOLLEN.

51. **Worsted and Woollen.**—Having now considered the processes employed in the sorting and washing of wool, it is well to understand what is the difference between the two sorts of yarn, worsted and woollen, into one of which it must be spun. Every spinner knows which class of yarn he spins, and most persons familiar with the trade could tell at once whether any given piece of yarn was worsted or woollen, but at the same time might find it difficult to say what characteristic it was which made yarn belong to the one class, and not to the other. Yet it is essential to know the difference between the two in order that the principle of the various operations in their manufacture may be properly understood.

52. **Former distinction untenable.**—It used always to be said that worsted was made of long wool which was combed, and woollen of short wool which was carded; the characteristic difference between these two processes being, that in the former the short wool is separated from the long, which alone is spun, while in the latter the short wool remains mixed among the long, and all the little lumps and knots are opened out by the action of the card-wires, so that the yarn may be comparatively smooth, and yet gain in bulky appearance owing to the short hairs in it. Formerly this was ap-



proximately correct, but it is no longer so; and the distinction, even if correct, would be entirely unscientific, because it leaves unanswered the question, Why must a worsted yarn be combed and a woollen one carded? what is the principle of the two processes which makes the difference in the result?

53. **Difference not in length, nor in combing and carding.**—In the first place, the terms “long” and “short” are too vague, for, owing to the increased perfection of machinery, wool less than 2 inches long can be combed, while other wool of 6 or 8 inches is regularly carded, and even wool of much greater length can go through the cards with little injury. Botany wool of two inches long is made into merino cloth; while Cheviots, and other similar wools of 5 or 6 inches long are made into rough woollen goods. It is clear, therefore, that the distinction between worsteds and woollens depending on the length of the fibre is no longer tenable. Nor is the distinction that one is combed and the other carded satisfactory. All woollen yarns are carded or, to use another name, “scribbled;” but a large proportion of worsted yarns are carded also. There are three main classes of worsted yarns, which, however, to some extent overlap each other. The first is composed of long English and similar wool, which is combed after passing through what is known as “preparing boxes.” Of the second class, yarn made of Botany wool may be considered representative, for the wool is short, and is first carded and then combed. Carpet yarns and coarse “fingering,” or knitting yarns, compose the third class, and are made of wool of various lengths, which are carded without being combed afterwards, as the object in making them is to have them soft and bulky. These different classes cannot be kept distinct. A “top” of combed English wool may be mixed with one of carded and combed Botany to give it a finer quality; or the carpet yarn may have some combed wool to make it more level, and other combinations may be made. This

shows that the idea that worsted yarn must be combed, and that all carded wool is spun into woollen yarn, is entirely erroneous, and a more accurate distinction must be found.

54. **Difference not in Mule and Throstle.**—By some persons it is supposed that this distinction lies in the spinning-frame; woollen yarn being spun upon the “mule,” and worsted yarn upon the “throstle.” The chief characteristic of the latter frame is that the yarn is twisted and wound upon a bobbin as fast as it is delivered by the pair of rollers which draw it out, and as this pair of rollers revolves constantly while the spinning-frame is in motion, the principle of the throstle frame is known as “continuous drafting.” The characteristic of the mule, on the other hand, is that the thread is drawn out by the rollers for about two yards before it is wound on to the bobbin, being kept stretched by means of the spindle and bobbin on which it is to be wound, travelling away from the rollers on a “carriage.” In some cases, the rollers cease delivering when the carriage has gone about half its distance, and the yarn is then drafted by the carriage proceeding to the end of its journey and drawing out the rove which has been thus delivered. In other cases the rollers deliver as long as the carriage travels outwards; but in either way more twist, if necessary, can be put into the yarn by the spindle continuing to revolve after the rollers have ceased to deliver, and finally the yarn is wound on to the bobbin as the carriage which bears it again approaches the rollers. In consequence of this stoppage of the rollers, the drafting or drawing out of the yarn is not continuous. The former of these modes of mule spinning is most suitable for woollen yarn; while the principle of continuous drafting, and the latter mode of mule spinning, are most suitable for worsted. Woollen yarn has, until recently, been spun only on a mule since that machine was invented, but a spinning-frame upon the throstle principle of continuous drafting has lately been

made which is suitable for a sort of woollen yarn. Worsted certainly is spun upon the mule, the latter frame being chiefly in use on the Continent, and to a small extent now in this country, and it is found to be suitable for spinning combed as well as carded wool.

55. **Nor in Milling.**—As this distinction is untenable, we turn to another which is generally believed to be correct, namely, that woollen fabrics are milled or felted, while those of worsted are not. This is a still more unsatisfactory definition, because it deals with the cloth, whereas it is obvious that whatever difference there may be must exist in the yarn, seeing that both sorts of yarn can be woven in the same way. The definition also is not exhaustive, because some woollen cloths are only scoured and not milled, while some worsted ones (such as coatings) are slightly milled to give them greater firmness. There are also mixtures, of which the warp may be worsted and the weft woollen, and these may or may not be milled. As a rule, however, woollens are milled and worsteds are not, and it is indirectly in connection with this end that the solution of the problem is to be found.

56. **Difference lies in Arrangement of Fibres.**—The difference between worsted and woollen depends really on the arrangement of the fibres in the thread, and this indirectly depends on the fact that the fibres arranged in one way are less suited for felting than if they were arranged in another. This is not the place to describe the operation of milling or felting, further than to say that its object is to entangle and mat all the fibres of the cloth so thoroughly into one homogeneous whole, that each thread can no longer be distinguished, and the cloth forms a solid and compact piece. Now, as most woollen cloths are intended for felting, it is necessary to prepare and spin the yarn in such a way as to facilitate the operation; and in consequence of the shrinking which takes place in the cloth owing to it, any slight imperfections, such as unevenness, are not easily seen.

**57. In Worsted, Fibres lie Smooth and Parallel.**—In worsted fabrics it is different. They are not as a rule intended to be felted, and therefore it is of the highest importance that the yarns of the better sorts should be level, smooth, and free from lumps of any kind, while even in the lower ones, such as carpet yarns, it is very desirable to have an even thread. To ensure this, and to have a smooth surface on the cloth, all the fibres of wool must be in the same direction in the yarn. That is the essential characteristic of a worsted thread. If the fibres are doubled up, crossed, or tumbled about in any way, it is impossible to have a really even thread. To insure this levelness, it is necessary in the finer yarns to remove, by means of combing, all the very short fibres and the knots and lumps which are inseparable from them. In the coarser sorts, such as carpet yarns, where this high degree of excellence is not needed, and where it is necessary to have a soft bulky yarn, it is not desirable to remove the short fibres by combing; but yet the wool is put through certain processes to ensure that, as far as possible, the fibres shall all lie in one direction.

**58. In Woollen, Fibres lie Roughly and Crossed.**—Compare this with a woollen thread. In it, instead of lying smoothly and having a regular twist to bind them together, the fibres are crossed and doubled in every direction. The thread is consequently rough and many loose fibres are seen to stand out from it. These are of great use in assisting the felting of the cloth, as they lay hold of each other and knit the different threads into one piece. The beauty of worsted is to have as few of these loose fibres as possible, and at the same time to have a round level thread, because the thread is seen in the woven fabric. On the other hand, as the woollen cloth is generally intended to be milled, the fibres must be arranged in such a way as to assist that operation; and it is found that when the fibres of wool lie in all possible directions in the thread, and when many of them stand out from the surface of it, their serrated edges are more

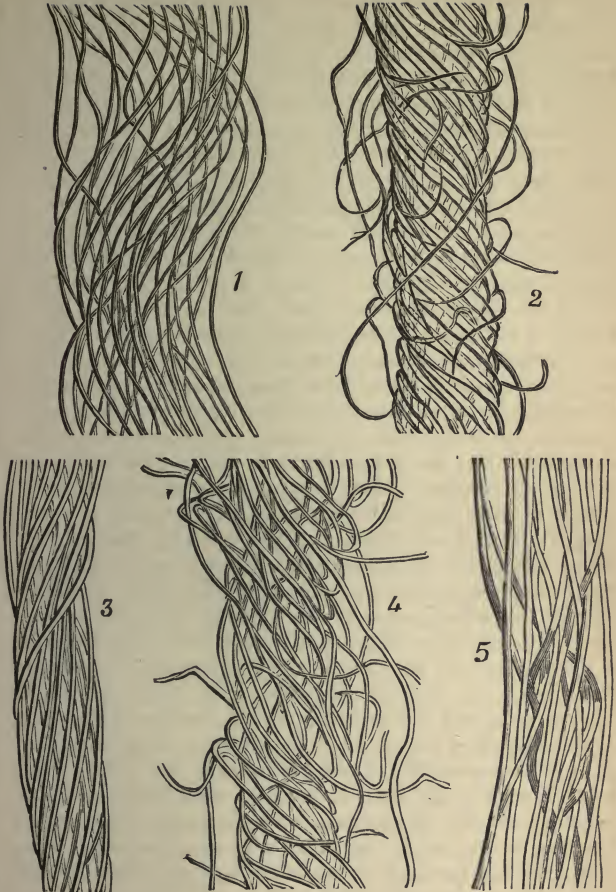

Fig. 9.—Woolen and Worsted Yarns (Threads)  $\times 50$ .

1, 30's worsted made of fine wool; 2, 30-skein woollen made of fine wool; 3, 30's worsted made of strong wool; 4, 28-skein woollen made of Cheviot wool; 5, 30's lustre worsted.

exposed than when they lie smoothly stretched out in straight lines. In other words, by this rough arrangement of the fibres they get hold of each other better, and lap round each other more firmly in the felting; because as wool shrinks in the process, a fibre which is wrapped round several others will get a firmer grip of them than if it is stretched out lying by their side with very little twist in it.

59. **Appearance of the two Yarns.**—The accompanying wood-cut (Fig. 9) shows more plainly than any description could do the difference in the construction of the two classes of yarn. Nos. 1, 3, and 5, are worsted; the first, being made of short fine wool, cannot lie so smoothly as the other two, because when the fibre is short, the waving, curly nature of the wool asserts itself, for there is not sufficient resistance in the short length to keep it straight. In Nos. 3 and 5 however, the wool is long, perhaps twelve inches or more, and therefore it lies straighter; for if the tendency to curl be strongest in the middle of any given fibre, it is clear that if it be twelve inches long the resistance of six inches at each end, which are stretched out and twisted round other fibres, has to be overcome before the curl can commence. It is simply a question of the strength of the tendency to curl contending against the friction which the fibres exert on each other after they have been stretched out side by side. In long wool the friction is the stronger force and the fibres lie straight. In short wool the tendency to curl is stronger, and the reverse is the case. This is the chief reason why short rather than long wool is suitable for woollen yarn. This will further be seen from Nos. 2 and 4, in which no attempt has been made to straighten the fibres, but every chance has been given to them to take advantage of their natural characteristics, and they are so arranged as to be able to felt with each other with the greatest facility.

60. **Processes designed to assist these characteristics; Worsted.**—A few words as to the processes which

the wool goes through before spinning will show how everything is done to encourage the main characteristic of each yarn. Take, then, the three classes of worsted yarn already mentioned. The first, made of long combed wool, is being straightened in every process after it leaves the dryer. Before combing, it passes through a number of "gill boxes," which will be described later on, but the effect of which is to separate all the fibres from each other and to lay them parallel side by side. The wool is being continually combed through rows of steel pins, or drawn through them by means of revolving rollers. Then it is combed to separate the long wool or "top" from the very short or "noil," an operation which in itself stretches the fibre so much as to destroy a good deal of its curl. After combing, the top requires to be drawn out to a small thread to make it ready for spinning, and it is passed through a number of machines and wound on to bobbins, each time with the fibres in a state of considerable tension, until at length the inclination to curl is nearly destroyed. With the second class of worsted yarn—viz., that made of short wool, Botany and other similar sorts—the same preparation before combing is not possible, the staples of the wool being too short to be caught and opened in this way. It is therefore carded, which may tend to increase the curl, and it is only after that operation that it is straightened by combing and drawing in the same way as the long wool. Carpet yarn, the third class of worsted, gets even less straightened than Botany, for as it is desirable to retain all the short wool in it, it is merely carded and not combed; but still after the carding, it is passed through a number of gill boxes and all the drawing machinery, and thus to a very considerable extent the fibres are made to lie straight. For be it observed, the rollers which draw out the wool always get hold of each fibre by one end and so pull it straight, and thus help to make the yarn level.

61. Process for Woollen.—The treatment for woollen

yarn is exactly the reverse of this. The wool is carded and never straightened afterwards. It probably goes through two carding-machines and a condenser—a machine which, instead of delivering the wool in one thick “sliver” or ribbon, passes it out in thirty or forty thin ribbons about an eighth of an inch in diameter, which are wound on to the rollers and taken to the spinning-mule. The first card often automatically feeds the second, and the second feeds the condenser; but whether this be so or not, the feeding is generally so arranged, that the sliver from the first and second, instead of going *lengthways* into the second and third, goes in *sideways*, and thus everything is done to prevent the fibres from being drawn out straight, and as they are then taken directly to be spun, they remain curly, as shown in Fig. 9, Nos. 2 and 4.

## 62. Definitions of Worsted and Woollen Threads.—

From what has been said it will be clear that any definition of worsted and woollen yarns cannot depend on the machinery by which they are made, nor on the use to which they may be put after they are spun. Neither can it refer to the length or quality of the wool. The definitions must depend entirely upon the characteristics of the yarn, as seen in the arrangement of the fibres. A worsted yarn, therefore, may be defined as a thread spun from wool in which the fibres are arranged so as to lie smoothly in the direction of the thread and parallel to each other. The fact that this smoothness is not always obtained does not invalidate the definition, but simply shows either the refractory nature of the wool, or the imperfection of the machinery or workmanship. The definition remains correct, and the more nearly worsted yarn approaches to perfection, the more nearly does it approximate to the above definition. A woollen yarn, on the other hand, is a thread spun from wool in which the fibres are arranged so as to lie in every direction, and to cross and overlap each other in such a way that they may present their serrated surfaces in the greatest variety of



ways. This crossing and overlapping of fibres is the characteristic of woollen yarn; and whatever change there may be in the machinery by which wool is spun, the object of the woollen-spinner will always be to have yarn in which the serrated surfaces of the fibres will present themselves in every direction, while the object of the worsted-spinner will be to have a smooth and level thread.

---

## CHAPTER V.

### PREPARING AND CARDING FOR COMBING.

63. **Different Treatment for different Yarns.**—It is now necessary to examine the methods by which yarn is made, and see how each process tends to produce the particular result which is desired. In the washing and drying of the wool there is no difference in principle, whether that wool is to be spun to worsted or woollen yarn, though there may be modifications in the processes according as the wool used is long or short; but when it is remembered that precisely the same class of wool can be used for both sorts of yarn, and that no distinction need be made till after the wool has gone through these processes, it is clear that the different result will depend on the treatment which the wool receives from the various machines through which it passes. We must, therefore, divide our subject, and will take the preparation and spinning of worsted first.

64. **Subdivision of Processes for Worsted.**—At the very outset we have to make at least three subdivisions, depending jointly on the quality and length of the wool and the purpose for which the yarn has to be used. These subdivisions only exist, however, up to the process of spinning, for here they can, to a certain extent, be re-united. We have already indicated in the last chapter what these are, but they must now be considered more

fully. They are (1) long wool which is prepared and combed; (2) short wool which is carded and combed; (3) wool of any length, but rarely very long, which is carded only. Into one of these all worsted yarns may be divided; yet strange to say, when the yarn is spun it is often quite impossible to tell by which process it has been made.

**65. Preparing by Gill Boxes.**—We will take first that wool which is prepared and combed. It includes nearly all British and Irish wool, the longer sorts of cross-bred Australian and New Zealand, and generally all wools which are to be combed, and which average five inches and more in length. It will be at once plain that above all things care must be taken not to break the wool more than can be helped, because as it is to be spun into worsted, with all the fibres lying stretched out side by side, the longer they are, the stronger will be the thread for any given twist, and the less twist will it be necessary to put in to make the thread hold together. In other words, the longer the fibres remain the better will be the spin. If this wool were carded, very many fibres would be broken, because when the wires on one roller caught one end of a fibre before the wires on another were ready to give up the rest of that fibre, the result would be that each roller would carry off half. With short wool this is not so, because by reason of their shortness the fibres do not cling to the wire rollers to the same extent, and so escape breakage. The method of preparing the wool for combing by means of screw gill boxes has therefore been invented. The principle of all these is the same. A pair of back rollers, B, as shown in Fig. 10, draw in the wool slowly at one side, and deliver it at the other side to rows of steel pins, fixed in steel bars, called fallers, which travel forwards by means of two screws between the threads of which they run. When the fallers come to the end of the screws they drop down on to another pair of screws which turn the reverse way, and so carry the fallers back again underneath their previous

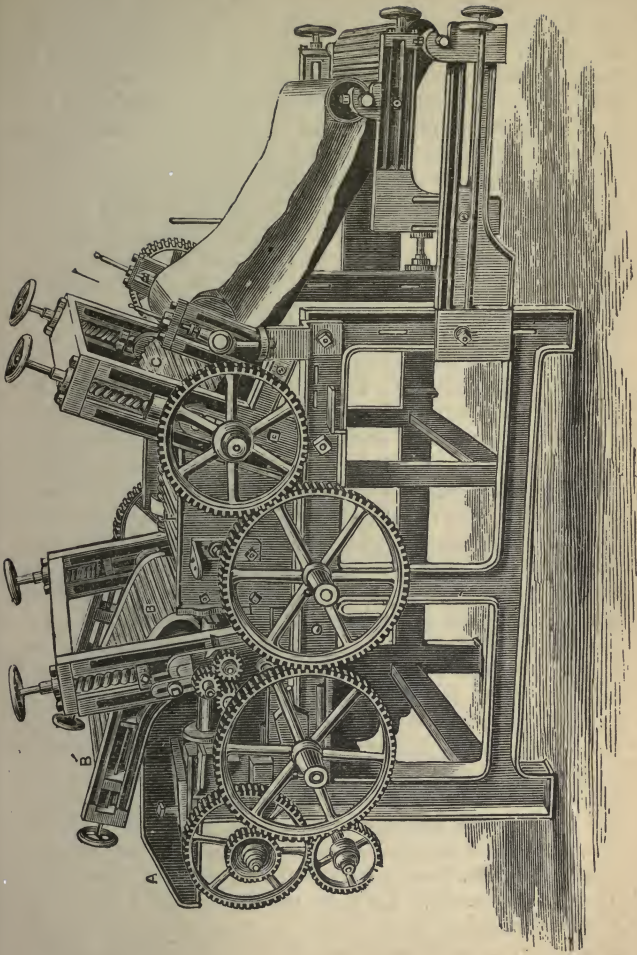

Fig. 10.

course. Arrived at the end of these, they are lifted up by means of cams fixed in the ends of the screws, and are again received at the beginning of the first pair of screws, and so recommence their forward journey. As the wool is delivered by the back rollers, the pins of the fallers rising up, pierce it, and travelling forward, bear it on till they come to the end of the screw, a distance which depends on the size of the box and the position it holds in the set of machines. Here it is taken hold of by another pair of rollers, *c*, running at a much greater speed, and drawn quickly out into a comparatively thin ribbon. Thus, in brief, a gill box consists of a pair of back rollers revolving slowly, a pair of front rollers revolving quickly, and a set of fallers carrying the wool forwards from the former to the latter.

**66. Principle of First Gill Box.**—Fig. 10 represents the first of a set of these gill boxes—five or six make a set, decreasing in size and strength as they advance. As the object of these machines is to straighten and separate the fibres of the wool preparatory to combing it, it is very desirable that they should enter the first box as straight as possible, for if they pass between the back rollers *B*, sideways or curved, the faller pins, rising up and travelling away from the rollers, are sure to break a good many. The only way yet discovered of effecting this is to have them straightened by hand, and therefore one or two men, called “makers-up,” are employed for each box to keep drawing the wool through their hands, making it into a kind of “lap,” with the fibres as much one way as possible, and then to lay it in between two leather or cloth travelling aprons, one of which travels round the projecting plate *A*, on which the wool is laid, and the other round the little roller *B'*, and the top back roller *B* lower down. These converge just behind the back rollers, and feed the wool into them. There is probably no part of the entire business of worsted-spinning more neglected than this, nor is there one which is really more important, for with bad making

up more wool is broken in the first box than in all the others, because the wool is there more matted and irregular, and every broken fibre reduces the value of the combed wool or "top" if it remain in it, or decreases its quantity by adding to the "noil" or short wool, which is taken out. Too often broken-down men are employed, one to each box, who do their work in the most careless way, unless closely supervised by the overlooker. It cannot be too strongly impressed on both the worsted-spinner and his workmen that nothing costs him so much as wool, and that he may soon lose in destroyed wool as much as will pay for the wages of better workers, or the price of new machines. The master should therefore insist on his "making up" being done thoroughly and with care. In no case, however, can all the fibres be really straightened at this stage; and therefore, as soon as the wool passes through the back rollers its first danger awaits it in the shape of the fallers. Now if these travel slower than the circumference of the bottom back roller revolves, it is plain that the wool will be delivered more quickly than the fallers can carry it away. If they travel exactly at the same speed there will be no accumulation of wool, but it will have a tendency to lie on the top of the pins instead of being pierced by them, and thus it will not be properly drawn through them when it reaches the front rollers; or if by means of a brush, or any such contrivance, the wool is pressed into the fallers properly, the swiftly-revolving front rollers will draw it through the pins before it has had any better opening and straightening than the "maker-up" has given it, which means that the fibres would be dragged violently against the pins, and broken. But again, if the fallers travel faster than the back rollers, they will break the wool by dragging it away from the rollers more quickly than it is being delivered. It should be stated here that in all cases it is the speed and circumference of the bottom rollers that must be taken, because in every

machine in every process it is the bottom roller which is driven by the wheel. The top roller is always driven merely by the friction of the bottom one, and is pressed upon it by weights or screws, which are tightened down. Of course they must revolve at the same speed, or the wool would be ground to pieces between them. If the friction is great enough they will always run together. It appears, therefore, that there is only a choice of evils in the speed at which the fallers travel; and experience shows that the last of these is the least; and is, indeed, the only practicable method of working; therefore the fallers are made to travel faster than the rollers, while the evils are diminished in various ways. The back rollers can be drawn away from the fallers, so as to allow a few inches of wool to come through before it is drawn by the fallers; the pins of the fallers are set wide apart, about three per inch, and as the fallers themselves are  $1\frac{1}{4}$  inch across, the total number of pins is not great. The difference of speed between the fallers and the rollers is not very great, so that the breakage of wool is here reduced as much as possible, considering the machinery. But a fresh difficulty now meets us, namely, that in proportion as we decrease the risk of breaking the wool by not drawing it out as it leaves the back rollers, so we increase it when we get to the front rollers, by these having to draw the wool quickly through the pins without the fibres being previously opened.

**67. Clough's Gill Box.**—This difficulty has been surmounted by Mr. John Clough, of Keighley, one of the chief spinners in the trade, who has patented a gill box, of which a portion of the drawings is shown in Figs. 11 and 12. The principle of the box is to have two sets of screws and two sets of fallers, the set nearest the back rollers working slowly, and the set nearest the front ones working faster. By this means the back fallers draft the wool very slightly from the back rollers, a draft of two being enough; the front fallers run about three times as fast as the back ones, thereby

making a draft of three between the two sets of fallers, or a total draft of six from the front fallers to the back roller. The front rollers run at the usual speed, say

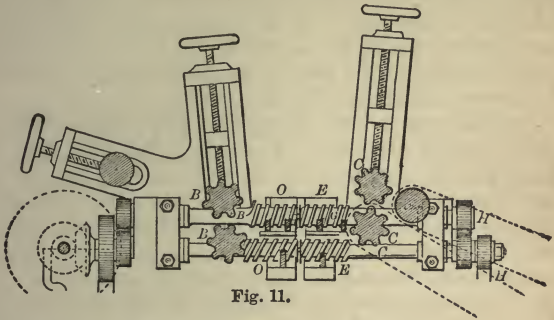

Fig. 11.

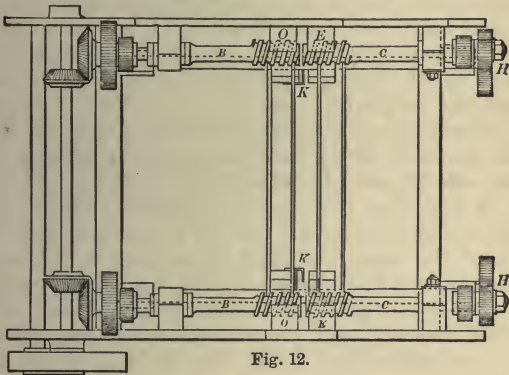

Fig. 12.

$3\frac{1}{2}$  times as fast as the front fallers, giving thus a draft of  $3\frac{1}{2}$  between them, which is equal to  $10\frac{1}{2}$  of a draft between the front roller and back fallers, and 21 of a draft in the entire box. There are thus three separate drafts in the box, and the total is obtained by multiplying these together. The leading idea of the machine is, that

when the quickly-running front fallers seize the wool, it is no longer held firmly by the back rollers, but is spread out and slightly opened in the back fallers, and therefore can be drawn through the pins of these latter with much less risk of breaking. It is recommended that the first three boxes of each set should be made on this principle, for the saving in the wool is so great as very soon to pay for the cost of the machines.

68. **Diagram of Clough's Gill Box.**—Fig. 11 gives a sectional view of one side of the box, Fig. 12 a flat plan of both sides, as seen from above. The back rollers are B B, the front ones C C; the back screws O O, the front screws E E. As the wool passes through B B, it is caught by the fallers travelling in the top screw, O, which carry it along till they reach the end of the screw, then they drop down and return to the lower screw, O. The second set of fallers in E carry on the wool, drawing it out from the back fallers, and so on to the front rollers C C, and then it goes down between the two aprons H H. The two sets of screws are driven one from each end of the box, the present method of doing this, by means of ordinary bevelled wheels, both at the front and the back of the box, being the arrangement of Mr. Prince Smith, sen., by whose firm of Prince Smith & Sons, of Keighley, the boxes are made. The other most noteworthy feature, and part of the patent, is that the ends of the back and front screws can be brought close together, and a thin plate of steel, K K, which serves as a conductor to guide the back fallers down, and the front fallers up, also prevents the two sets from running into each other. The idea of this is due to Mr. Kelly, who patented it. The improvement effected by this machine is so great that it deserves to rank among the leading inventions in the worsted trade.

69. **Set of Gill Boxes.**—We have dealt with the first gill box at considerable length because it is the most important, and because the description of it contains the principle on which every gill box works; and this once



understood, no further explanation at other stages will be needed. As has been already stated, a set of preparing-boxes consists of five or six in number. The second box is similar to the first, and it is recommended that for it, and also for the third, Clough's method should be used. They are not, however, so necessary here as in the first, for the reason that the wool has been very much straightened by the first operation, and the fallers of the second box, in leaving the back rollers, can therefore be drawn through the wool with much less risk of breaking it. Still, anyone who wishes to be careful will do well to have a set of three. The lap, which is made in front of the first box, is put up at the back of the second, and drawn through the rollers, while the front rollers again draw it out and make it into another lap, with the fibres straighter than before. This lap in its turn is put up at the back of the third box, and is treated in the same way. When it has passed through the front rollers of the third box, it is no longer allowed to form a lap, but is gathered together and made into a ribbon or sliver, by being passed through a round or oval hole in a piece of brass or steel, and then drawn down by a pair of smooth press rollers, which pass it into a deep tin can that stands underneath them. The dimensions of these cans are from thirty to thirty-six inches deep, and from ten to twelve inches in diameter.

70. *Levelling the Slivers.*—About six of these cans are put at the back of the fourth box, and drawn out by it into one sliver, generally rather thinner than any single one of the six which were put up; thus, if six ends are put up, the draft of the box would be about eight; that is to say, for every foot of sliver that goes in at the back of the box, eight feet will come out at the front, and therefore the sliver at the front will be just one-eighth the thickness of the combined slivers which went in at the back. Here we first clearly get the idea of *levelling as well as straightening*. Really the levelling has taken place in the previous boxes also, because if the length of

the lap, or the circumference of the apron on which it is made, be, say, four feet, and if the apron revolves thirty times before a thick enough lap is made, it is clear that thirty thin layers of wool have been put together; and so, to some extent, levelling has taken place in a rude way. As it only begins to be done systematically at the fourth box, we need only consider it from there. From the front of the fourth box six cans are taken and put up at the back of the fifth, and the same number will be taken from the fifth and put up to the sixth, if a sixth be used. The doublings which in these three boxes the wool has obtained are,  $6 \times 6 \times 6 = 216$ , and these, combined with a levelling in the first three boxes, make a comparatively level sliver. If the work has been well done, the fibres will have been well opened, and most of the large lumps and knots of wool separated and smoothed, though there will still be a vast number which only the comb can remove.

71. **Method of Oiling.**—If any oil is to be put on the wool, the back of the fourth box is a very convenient place for the process, for in the first three boxes much dust can be shaken out of the wool when it is unoiled. Some persons oil the wool on the dryer by sprinkling the oil over the wool by means of a watering-can; this method makes the quantity uncertain, as the dryer may not always be equally covered, and it is also an untidy and rude way. The best method is to have a trough full of oil fastened over the slivers as they pass under the back rollers of the fourth box. In it is a revolving cylinder, the lower half of which runs in the oil, and leaning against its upper half is a number of tin gutters or small troughs which have their higher ends against the cylinder and their lower ends projecting over the slivers. As the cylinder revolves it carries up the oil on its surface, scrapes against the upper ends of the gutters or small troughs and pours down them very tiny streams of oil which, drop by drop, fall on to the slivers as they pass under the rollers. The number of these gutters can

be increased or diminished according to the weight of wool passing through, or the quantity of oil which it is desired to use; and so long as the large trough is always kept about a uniform fulness, the quantity of oil put on the wool will never vary. As the slivers are doubled 216 times in the three boxes, the oil gets well spread over it all. The advantage of this method over a circular brush scattering oil spray is that the quantity put on can be varied at once by the number of gutters set to work or taken out. In case the wool has become too dry, water can be put on in the same way as oil at one of the other boxes. Wool can be combed better when it is not very dry, for the little knots can then be more easily kept out of the "top;" but if it is too wet, the "noil" will be made larger as more short wool will tend to remain in it. Only experience can teach the overlookers the proper amount of moisture to have in the various sorts of wool. For long lustre wool about three pints of oil per pack (240 lbs.) are enough. For shorter English and Irish, five pints may be used. For strong low wools much more is needed to produce the same effect. Where the wool is not to be spun out to its fullest extent it is often better to use no oil at all.

**72. Special Points needing Care.**—Before leaving the subject of preparing, it will be well to direct attention to a number of points which require care. The first of these is the distance of the back rollers from the fallers. Where long wool or wool that is matted is used, the rollers should be far back to give as much freedom as possible to the fibres before they are caught by the pins. With short wool, especially if it be skin wool, the rollers should be closed up, as otherwise the wool will offer no resistance to the fallers as they rise, and will simply travel forward on the top of them. This requires attention in every box; the best test is to feel the wool with the points of the fingers. If it is evidently stretched very tight, the rollers should be put back; if it is too slack and not getting into the fallers, they should come

forward. The bars of iron, called saddles, on which the fallers rest while they travel to and fro, need frequent attention, as they are apt to wear short. They should be long enough to let the fallers drop and rise almost perpendicularly with hardly any slanting motion. To ensure this, the saddle ends should be straight, with the upper part slightly shaved off, and they should be case-hardened to make them last well. Much trouble is often caused by fallers "locking fast" and getting across each other and so being strained, which is due to the saddles being too short. At the ends of the saddles are conductors. They press against the ends of the saddles, and are kept firm by springs pressed against them. As the fallers fall and rise they press the conductors away from the saddles, and thus glide smoothly down and up without any shaking. These conductors must be tight enough to keep the fallers firm, but not so tight as to hinder their easy working.

73. **Fallers.**—Fallers can be made either by boring holes direct into the steel bar and driving the pins through them, or by driving the pins through brass plates and riveting these plates on to the steel bars. The former is much the better way wherever the pins are coarse enough and far enough apart to allow it, as the faller can be made stronger; it avoids the trouble of the brass plate coming loose; also if any of the pins are broken they can be at once knocked out and new ones put in, the repair not taking more than a minute; while if rivets had to be knocked off and put on again, the labour would be considerable. For average English wool the number of pins per lineal inch in the fallers of the first box should be 3, in the second 4, in the third 5, in the fourth and fifth 6, and in the sixth 7 per inch. In the first three boxes there are two rows of pins on each faller. In the last three there may be single or double rows. Some pins are round, others are flat. The latter, though more costly, are better, for they are stronger to resist bending, and can be set nearer together. It is

surprising how quickly faller pins wear out and break, but it is of great importance that they should be kept in good repair. They either snap off in the middle, get the points bent, or split at the point. This last is, perhaps, the worst fault, and is caused by the fibres of wool always resisting the rise of the fallers, till every pin-point gets a nick or split in it. Then the wool rides on the top of the pins, and when the front rollers come to draw it out, it breaks, being held by the roughness of the pins. Such fallers should at once have new pins put in them.

**74. Draft of Gill Boxes.**—We now come to the somewhat puzzling subject of the “draft” of preparing-boxes. The “draft” may be defined as the difference in speed between the front rollers and the back rollers; or as the difference between the length of the material which comes out of a machine, and that which goes into it. Thus, if one yard of sliver goes in at the back rollers, and in the same length of time ten yards come out of the front rollers, the draft of the machine is ten, for one yard is drawn out or drafted into ten. A gill box, however, has two drafts, the draft between the fallers and the back rollers and that between the front rollers and the fallers. There is also, of course, the draft of the whole box between the front rollers and the back rollers, which is made of the other two multiplied together; but it is not enough to know this, because it might be right in the total, and yet wrong in its component parts—one, perhaps, being too great, and the other too small. There are very few overlookers who know how to take these drafts, as they find guess-work more simple. Let us take the draft of the second box, assuming it to be one of the usual make, and not Clough’s patent. It is first necessary to divide all wheels into two categories, “drivers” and “drivens” as they are called, according to the effect they have on the speed of the part of the machine they work when they are increased or diminished in size, *i.e.*, in teeth if they be toothed wheels, in circumference if they be plain wheels or rollers. Thus, for example: given

any speed of a shaft, if a drum on it be increased in size, whatever it drives will go faster. But if it drives a pulley on a preparing-box, then if that pulley be increased in size, it will run slower, and the box, of course, will run slower too. The drum is called a "driver," for more size gives more speed to what it drives. The pulley on the box is called a "driven," for more size makes it go slower, and makes whatever follows it go slower too. So with all the wheels in every machine, except certain ones which for every tooth they are moved simply move the next wheel one tooth also. These merely transmit motion without affecting speed, and are called intermediate wheels. Having examined the box to see which wheels and rollers come under each category, it is necessary to multiply each together, divide the larger by the smaller, when the quotient will give the draft. To any one watching the box in motion this is not difficult. In the box we take for an example, which is the same in principle as all other boxes, it will be found that there are two back shafts. On the lower one are the pulleys, which are driven from the main shaft, and also the wheel which gives motion to the upper back shaft. The upper back shaft drives the screws by means of bevelled wheels, and the back and front rollers by intermediate wheels. On this latter shaft is a wheel with 20 teeth, driving the following wheels in their order: 75, 22, 75, 25, 75, the last being on the end of the back roller. If the 20, 22, or 25 were increased, it would cause the back roller to run faster, or if the back roller were increased it would have the same effect, one revolution drawing in more wool. Such changes would give less draft, because more wool would be drawn in by the back rollers, while the speed of the front rollers was unaltered. If the three 75 wheels were increased, the opposite would be the effect. On the upper back shaft we also find a 27 driving a 70, with two intermediate wheels between, the 70 being on the end of the front roller. If the 27 be increased, it would make the 70

and the front roller go quicker, which is the same in effect as making the back roller go slower. If the front roller be made larger a similar result follows. These must therefore be classed as "drivens" in this case, because we are going to take the draft of the whole box by the speed of the back roller. If the 70 be increased, the opposite is the case. The two (back and front) rollers are each 3 inches in diameter or 9.4 circumference. The equation therefore stands :—

$$\frac{75 \times 75 \times 75 \times 27 \times 9.4}{20 \times 22 \times 25 \times 70 \times 9.4} = \frac{18225}{1232} = 14.7.$$

The cancelling and other working are omitted. This is the draft of the entire box. We have now to get the draft between the fallers and the back rollers. The speed and pitch of the screws have to be taken here, and the wheels driving the front roller left out. The bevelled wheel driving the screws is 18, and the bevelled wheel on the screw end is 20, while the pitch of screw is, in this box,  $1\frac{1}{8}$  inch. If the 18 be increased, the screws will run faster, thereby making the fallers travel faster away from the back roller, which is equal to the back roller running slower, and if the pitch of screw be increased, the same effect will be found. If the 20 wheel on the screw end be increased, the effect will be the opposite, the screws going slower. We have to find first the number of fallers which rise for one revolution of back roller. The equation is :—

$$\frac{75 \times 75 \times 75 \times 18}{20 \times 22 \times 25 \times 20} = \frac{6075}{176} = 34\frac{1}{2} \text{ fallers rising.}$$

Multiply this by  $1\frac{1}{8} = 38.8$  inches, which the fallers travel for one revolution of front roller. Divide by its circumference, 9.4, and the answer is 4.1, the draft between the fallers and back roller.

**75. Draft between Front Rollers and Fallers.—**  
From this point there are three ways of getting the draft

between the front rollers and the fallers. In the first place, it is the quotient of the draft of the whole box divided by the draft between the fallers and the back rollers :—

$$\frac{14.7}{4.1} = 3.58;$$

*i.e.*, if one foot goes in at the back rollers, the fallers draw it out to 4.1 feet, and the front rollers draw each foot of this out to 3.58 feet, or the total 4.1 feet out to 14.7 feet, which is the whole draft of the box. Again, the draft of the whole box multiplied by the circumference of the front roller, and divided by the number of inches which the fallers travel for one revolution of the back roller gives the answer :—

$$\frac{14.7 \times 9.4}{38.8} = 3.56.$$

The third way is to take the wheels which drive the front roller, *viz.*, the 27 and 70, the circumference of the front roller 9.4 inches, the wheels driving the screws, *viz.* 18; the wheels on the ends of the screws, *viz.*, 20, and the pitch of the screws  $1\frac{1}{8}$  inch. We have to place together all those which, if enlarged, have the effect of increasing the speed of the front roller, thereby causing more draft. These are the 27, the circumference of roller 9.4, and the 20 on the screw end. If this last be enlarged, the screws will go slower, taking less wool to the rollers, and therefore causing more draft. The 70, 18, and pitch of screw are the reverse. The first, if increased, would make the front roller go slower, while the last two, if increased, would cause the fallers to travel faster, supplying more wool, and therefore causing less draft. The equation, therefore, is :—

$$\frac{20 \times 27 \times 9.4}{18 \times 70 \times 1\frac{1}{8}} = \frac{56.40}{15.75} = 3.58$$

the draft of the front roller. This is the correct way to take the draft, because it can be done without the



trouble of first finding the draughts of the other parts of the box. The two other ways are given, however, to show the relation in which the different parts stand to each other. The draft can, of course, be altered to any extent, by changing the 27 wheel, which is called "the change-wheel" of the box. If a larger wheel is used, it gives more draft. It is a noteworthy point that in all the machines connected with worsted-spinning, with the exception of gill boxes, the change-wheel is so arranged that a larger wheel gives less draft. As it is termed, "more gives less." But in gill boxes the reverse is the case, and "more gives more." As will be seen again later on, the reason of this is simply that the change-wheel of a gill box acts directly on the front roller, and is a "driver." A larger wheel gives more speed to the front roller and therefore more draft. In all other machines the change-wheel, also a "driver," acts directly on the back roller, making the roller go quicker as it is itself increased. But where the speed of the back roller is increased while the front remains unaltered, the draft of the machine is reduced; therefore "more gives less" draft must be remembered of spinning-frames and other similar machines.

76. Suitable Drafts for set of Boxes.—The following is a list of suitable drafts for a set of five preparing-boxes :—

I.	Back roller	6·3	Front	3·3	Pitch of screw	$1\frac{1}{4}$
II.	"	4·1	"	3·5	"	$1\frac{1}{8}$
III.	"	3·2	"	4	"	1
IV.	"	1·5	"	5·7	"	$\frac{3}{4}$
V. and VI.	"	1·2	"	6·7	"	$\frac{1}{8}$

These drafts are suitable for English skin and fleece wool six or eight inches long. For longer wool more draft is needed in the front rollers, and the whole can be altered to suit various wools. It will be seen that the back draft steadily decreases while the front draft increases. This is because after each operation the wool has been

made straighter and more even, therefore there is less need to perform the slow drafting operation at the back, as the fallers would simply slip through the wool, having no particular effect on it. But just because the fibres are now straighter, the front rollers can draw them without breaking through the faller pins, thus really combing the wool, and helping to make the slivers more level. It is well not to have too much front draft, as the leathers on the bottom front roller will then last longer, and for the same reason the rollers should not be heavily weighted, as the leathers are very apt to be cut by heavy pressure.

**77. Preparing for Mohair and Alpaca.**—The method of preparing mohair and alpaca is substantially the same as that for wool, but more operations are needed. The length of alpaca is one of its difficulties, but otherwise it can be worked well if not too much washed. As its lustre is its chief feature there is a great temptation to wash it well, and even to back-wash it. This latter operation increases its brightness very much, but makes the fibres so loose and wild that they cannot be made to lie together again without excessive oil, which is also an evil. Mohair is quite simple to work, but it needs always to be double-combed to take out the kemps, which are very numerous. So large has the noil to be made, that it is often combed over again and a short low top made out of it.

**78. Carding before Combing.**—We now come to the second method of preparing wool for combing, viz., by carding it. It will not be necessary in this place to describe the operation of carding at great length, because it will be more fully treated under the head of woollen carding. The principle of the two is alike, but there are several differences which must here be noted, arising chiefly from the fact that in one case the wool is to be combed after carding, and that in the other it is taken to the mule direct from the condenser card; but partly also from the different length of wool generally used in

the two cases. If the wool to be carded is more than about three inches long, it is not advisable to put it at once into the cards without previous opening, for if the first swift or large cylinder seizes it immediately it has passed the lickers-in, it will run a great risk of being

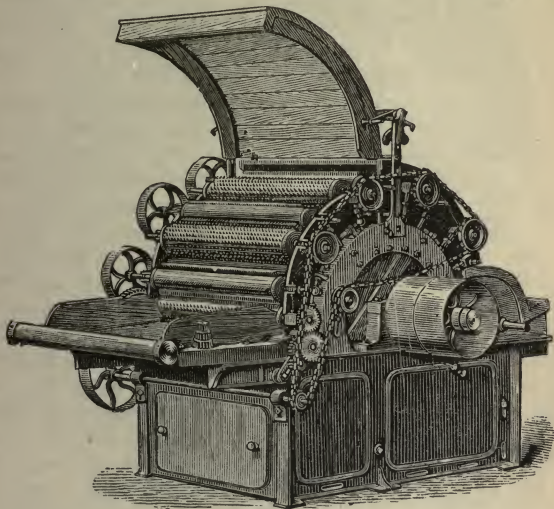

Fig. 13.

broken, and the wires of the swift will also suffer by the wool being somewhat fast or matted together. There are two ways of obviating this evil, either by putting the wool first through a tenter-hook willey to open it, or by having a number of slowly-revolving rollers between the first licker-in and the swift.

79. The Tenter-Hook Willey. — The tenter-hook willey (Fig. 13) has long been in use, and is in principle a small carding machine, with one swift covered with steel teeth, set at intervals of a few inches, and slightly hooked. Small rollers revolve above it the

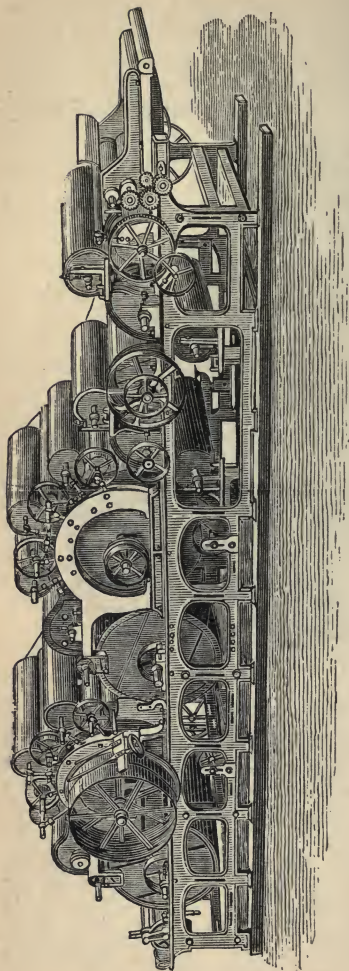

Fig. 14.

reverse way, every alternate one being covered with similar teeth, and the others being merely wooden rollers with leather beaters to clear the wool out of the teeth of the former. As the wool is fed into the machine it is caught and carried upwards by the swift and passed between it and the small rollers. By this means any fast or matted pieces are opened, and the wool which is thrown into a large box or small room at the other end of the machine, appears all loose and opened. This is certainly an effectual way of opening the wool, and it gives a convenient opportunity for oiling, the oil being sprinkled over it by a circular revolving brush as the wool is fed into the wiley. But it is a method which cannot fail to break a great

number of fibres, and therefore is essentially faulty, for the object must always be to preserve the fibres uninjured.

80. **Lickers-in or Opening-Rollers.** — The second method is, therefore, the one adopted by first-rate carders, who have a number of strongly-covered lickers-in or opening-rollers revolving slowly before the first swift, as shown in Fig. 14, and made by Taylor, Wordsworth and Co., of Leeds. These are either covered with leather

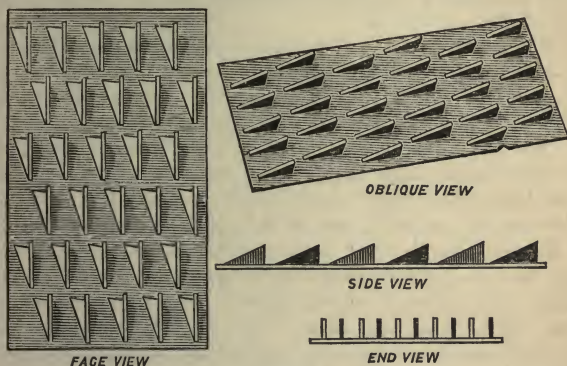

Fig. 15.

filleting with very strong teeth set in it, or else with steel clothing. The method of making the latter is, to prepare very thin long bands of steel, and then to cut out two sides of the teeth in them, as shown in Fig. 15, turning the teeth up at right angles to the band or fillet, and then winding the fillet round the roller. These are, of course, exceedingly strong and sharp, and remain so for a very long time. As the opening-rollers are placed nearer to the card proper, their clothing becomes finer, and they revolve somewhat more quickly, but still at such a moderate speed that there is little risk of the wool being broken. This is in principle not unlike Clough's preparing-boxes, which first partially open the wool by slow-going fallers, before the quicker fallers, and still

quicker front rollers, seize it; the object of both being gently to open the wool before the process of really straightening it out commences. Between these opening-rollers and the first swift, there is often placed what may be called a preliminary swift, usually known as a "breast," which has on it workers and strippers in the usual way. These all revolve more slowly than the after portions of the card, so that by the time the first swift takes the wool, it is not too much to say that half the carding has been done.

**81. Arrangement of a Card.**—When so much is done by the opening-rollers and the breast, two swifts are enough, each with four workers and four strippers, an angle stripper, and a "fancy" running on them.

The swift revolves at about 80 to 100 revolutions per minute in the direction of the card, *i.e.*, carrying the wool forwards to the "doffer" in front of it. The workers, which revolve slowly, run in the opposite direction to the swift, and though they never touch the swift, being set just so as to clear it, they receive the wool from the swift as the latter rapidly passes them. The strippers, which run quickly, go the same way as the workers, their function being to strip the wool off the workers, and give it back to the swift. This process goes on as long as there are tufts of wool standing out from the swift, but when the last worker is passed the wool may be said to be smoothed down. It then reaches the "fancy," which is the only roller that runs into the swift. It is covered with long very pliable wires, and acts as a brush to raise up the wool from the wires of the swift. To accomplish this it must revolve considerably quicker than the swift, but as the wires in it point the same way as those in the swift, it does not carry off any wool, but merely brushes it up. That is done by the doffer, though it would perhaps be more correct to say that the swift lays the wool on the doffer rather than that the doffer takes, or doffs it off, the swift. This is because the doffer runs slowly and the swift quickly. The points of the wires on

each are set the same way as shown in Fig. 16, and, therefore, as the front part of the swift quickly passes the back part of the doffer, it meets all the points of the latter standing up, and deposits its wool upon them. The doffer simply carries these round, either till it meets the

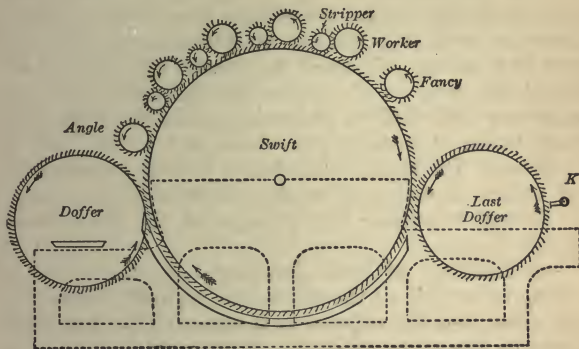

Fig. 16.

angle stripper on the next swift which receives its wool, or in the case of the last doffer, till it comes to the doffing knife or comb (K), which works quickly up and down, combing the face of the doffer downwards, and thus taking off all the wool in its carded state. This wool is gathered together and passed through a pair of press rollers, and thence it either passes into a can or is wound into a ball, the latter being the usual way as most convenient for storing.

82. **Burring Rollers.** — If the wool, as not unfrequently happens, is full of burrs and other small seeds, these must be cleared off before it is carded, both because the burrs would spoil the fine card wires, and because when they are opened by the card they lie along the fibres of wool and are exceedingly difficult to remove. To clear them off, burring rollers are fixed on the top of

two of the lickers-in. These are small rollers which revolve at a great speed, not covered with card cloth, but which run so close to the licker-in rollers as to knock off everything that projects above it and offers any resistance. The burrs do both of these things, and thus are hit by the roller and dashed into a tin tray suitably placed close to it across the card. Sometimes even three of these rollers are used, and then the wool is as nearly cleared of burrs as possible. To assist the process by loosening the hold of the wool on the burrs, the licker-in rollers are sometimes made hollow, and steam is allowed to fill them, being blown through pipes which run in the axle of the roller. The application of heat always loosens wool, and makes it easier to work; as we shall see, combs are heated to render the passage of the wool easier through them.

83. **Carding without Combing.**—As the object of carding is to open all the fibres and separate them from each other, the film of wool as it comes off the last doffer should be like a fine net-work, showing all the fibres, but free from lumps, and with the short wool as much opened out as the long. But as the wool we are now dealing with is to be combed, it does not matter if the carding has not been very thoroughly done, because all the lumps and any short wool will come out in the noil. If, however, we now take the third process for preparing wool, of which we have previously spoken (p. 53), viz., carding it only without any combing, and drawing it (*i.e.*, preparing it for spinning) direct from the card balls, as is done with carpet and low-knitting yarns, we shall see that the carding must be very carefully done, and all the little lumps must be opened out; for if not, there is no other machine in the process that can do it. It is common for wool which is only to be carded to have three swifts with the full number of workers, &c., on them; but if the card clothing be kept in thoroughly good order and well ground, so as to have the points sharp, very good work can be done with two-swift cards



as above described. Indeed, if good work can be done with two swifts, they are better than three, both because they are cheaper to fit up, and because the less the wool is worked, the less will it be broken, and there can be no greater error than to send wool through an unnecessary number of processes in any class of operations.

**84. Difference between Preparing and Carding.**—The difference between the prepared and carded wool, and between the operations, is now plain. In the former, from the first the fibres have been stretched out as straight as possible, and all the wool has been opened out, except little staples which have been too short for the rollers or fallers to get well hold of. These remain in, and have to be taken out with the rest of the noil in combing. The carded wool has none of these in, for short equally with long staples have been opened in the cards. The fibres, however, are lying in all directions along and across the sliver, which is made by winding the wool on to a ball. Until these are straightened the wool cannot be combed, or if it were, the amount of noil would be very great. The wool is, therefore, passed through one or two gill boxes, like the fifth and sixth in the preparing-set.

**85. Capability for Milling not affected by Gilling.**—Another remark in reference to carding and gilling should be made. It is often stated that one reason why prepared wool is not so suitable for milling as carded wool is because its passage through the steel pins of the gill boxes and combs breaks off the serratures from the fibres or blunts their points. Consequently, they have not the same power of interlocking as before. Wool that is carded, it is said, does not suffer in the same way, the effect of the operation being to open the serratures and make the fibre rougher. It is very unlikely that this is the case. When it is considered that there are from 1,200 to 3,000 serratures per inch in the fibre, and that the wool is oiled before it is carded or combed, it will be obvious that the action of the steel pins of the fallers, or

the wire of the cards, cannot have much effect on the small points that are presented to them. But if any be broken off, it is more likely that the breakage will happen in the cards than in the gills, for the treatment the wool receives is rougher in the former than in the latter. As the fibres are torn and pulled by thousands of short wire pins, placed in rapidly-revolving cylinders, there is every chance that if damage can be done to the points of the serratures, it will be in the operation of carding rather than in the comparatively slow and gentler operation of preparing and combing. But the oil which is mixed with the wool no doubt protects the serratures from breakage, and as it is removed by scouring before the cloth is milled, the serratures then remain free and open to interlock with each other.

86. **Back-washing.**—Wool may become rather sullied with carding, and is generally back-washed to give it a good colour. This process consists of passing a number of carded slivers through a sud of hot soap and water, and then over copper drums heated with steam to dry them again. In Fig. 17, as made by Taylor, Wordsworth and Co., of Leeds, the sud tank is behind the wheels at s. The drums are at D D, and though only four are shown here, there is often double that number. This machine is fitted up with a screw gill box, G, and an oiling motion, o; so that when the sliver comes dry from the drums it may be oiled and straightened, and thus an operation is saved. It is said that wool thus back-washed never spins quite so well as if it were not so treated, and there is probably some truth in the assertion. But the fact that a much better colour is gained, and the better price which both the top and noil consequently fetch, make the custom of back-washing after carding almost universal.

87. **Card Clothing.**—Nothing has been said so far regarding feeding the cards, nor as to the proper covering for them. These will be left till we can consider the whole subject later on; but no rules can be laid down as

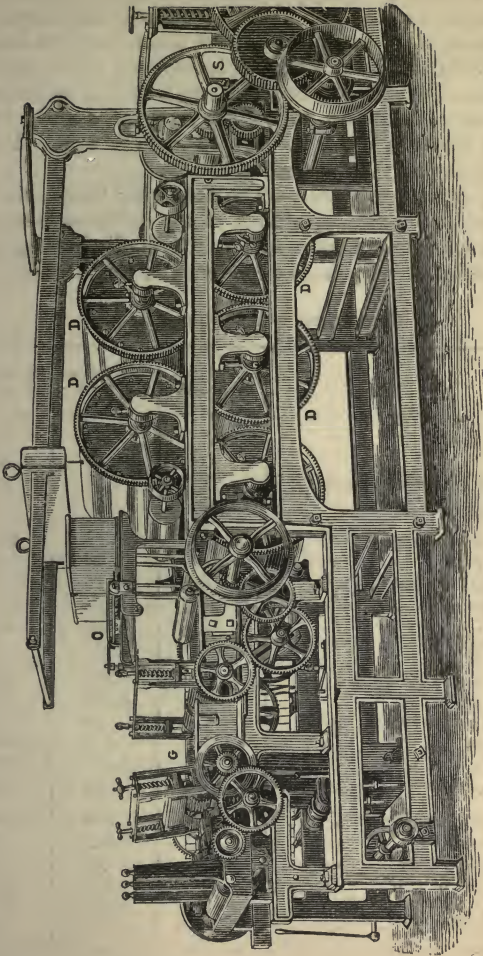

Fig. 17.

to the covering, because it depends entirely on the class of wool used in each mill. The wool which is carded and then combed is usually fine and short, such as Botany, and, therefore, the cards must be covered with very fine clothing. For those sorts which are intended to be carded only, coarser clothing will do, as they are usually coarse wools. But it is a safe rule to follow to have the clothing too fine rather than too coarse.

88. **Speeds of Cards.**—The following tables, showing the speed and surface velocity of the different rollers on old-fashioned and modern cards, have kindly been supplied by a friend of very great experience in carding:—

OLD STYLE OF CARDING ENGINE.

	Diameter in inches.	Feet per minute.	Revolutions per minute.
First taker-in . . .	10	65	23
Breast . . . . .	40	350	33
Two workers over breast . .	7	16	—
Two strippers „ „ . . .	5	420	—
First angle stripper . . .	7	612	300
First swift . . . . .	48	1,150	90
Workers over swift . . . .	7	16	8
Strippers „ „ . . . . .	5	420	284
Fancy . . . . .	14	1,820	450
First doffer . . . . .	24	44	6 $\frac{3}{4}$
Second angle stripper . . .	7	520	255
Second swift . . . . .	48	1,150	90
Workers over swift . . . .	7	12	6
Strippers „ „ . . . . .	5	420	284
Fancy . . . . .	14	1,820	450
Second doffer . . . . .	24	35	5 $\frac{1}{2}$
Third angle stripper . . .	7	520	255
Third swift . . . . .	48	1,150	90
Workers over swift . . . .	7	10	5
Strippers „ „ . . . . .	5	420	284
Fancy . . . . .	14	1,820	450
Third doffer . . . . .	24	29	4 $\frac{1}{2}$

MODERN CARDING ENGINE.

	For fine wool.			Coarse and medium wool.	
	Dia- meter in inches.	Surface feet per minute.	Revolu- tions.	Surface feet per minute.	Revolu- tions.
First taker-in . . . . .	20	55 0	10 $\frac{1}{4}$	54 0	10
First under-stripper . . . . .	12	152 0	46 $\frac{1}{2}$	97 0	29 $\frac{1}{2}$
Second taker-in . . . . .	20	236 6	44	150 0	28
Second under-stripper . . . . .	12	346 6	106	207 0	63
Third taker-in . . . . .	20	537 6	100	322 6	60
First angle stripper . . . . .	8	744 6	325	588 0	257
First swift . . . . .	50	1,196 0	90	957 0	72
Workers over swift . . . . .	9	15 0	6	15 0	6
Strippers " " . . . . .	3	318 0	325	251 6	257
Fancy . . . . .	12	1,935 0	540	1,180 0	324
First doffer . . . . .	36	67 0	7	67 0	7
Second angle stripper . . . . .	8	206 0	90	165 0	72
Second swift . . . . .	50	1,196 0	90	957 0	72
Workers over swift . . . . .	10	11 3	4	10 0	3 $\frac{1}{2}$
Strippers " " . . . . .	3	266 0	272	212 0	216
Fancy . . . . .	12	1,935 0	540	1,180 0	324
Second doffer . . . . .	36	41 0	4 $\frac{1}{4}$	41 0	4

These cards have only two swifts.

89. Modern Improvements.—The improvements here shown are, firstly, in the application of three takers-in working at a slow speed, and opening all the locks of wool before they reach the swifts, and thus preventing much breakage of the fibres. Burr rollers can be applied to each taker-in, and the under-strippers also throw out a great deal of dirt. Workers and strippers are sometimes placed above the takers-in. Secondly, larger doffers are used than formerly with greater surface velocity. The workers are also larger. Thirdly, for coarse and medium wool the swifts, fancies, and strippers are run much more slowly. This is a great advantage for short wool, and saves the shortest fibres from flying off, and the workers

and doffers are not so much choked. This follows the example of the woollen carders, who run swifts slow on account of the very short wool they use, sometimes as slow as sixty revolutions per minute. But for good fine wool this is no advantage. The speed of the fancies varies very much, almost every carder having his own ideas on the subject. The speeds here given, however, may be relied on as having been decided upon after much consideration. All the surface velocities here are calculated on the face of the wire, not on the bare roller; fractions are omitted. In all cases it is recommended that hardened steel wire should be used.

---

## CHAPTER VI.

### WOOL-COMBING.

90. **Hand-Combing.**—We have now to consider the various methods of combing; and, without describing every part of each machine, we shall indicate the principles on which each of the leading combs is worked. It is not



Fig. 18.

necessary to say much of the old system of hand-combing which is now extinct, but a few words may be given to it. Every comber had two combs similar to that in Fig. 18, and a post with an iron rod or stand fastened into it on which a comb would be placed while the other was worked. The wool was oiled and “lashed” on to (*i.e.*, partially drawn through) the pins of one comb, which was placed on the post during the process. It

was then heated on a stove, and the other comb treated in the same way. When both were charged with wool

and heated, the comber then placed one on the post, and, taking the other in his hands, kept combing the teeth of the latter through the wool on the former till all the wool was combed, and the fibres cleared of noil and made to lie smooth. He then drew off with his hands as much wool as he could into a sliver a few feet in length, and as even as possible. The small quantity of short wool left in the combs was the noil, and was sold as waste, to be used for making blankets. This was the universal method of combing until quite recently, when one invention after another destroyed it for ever.

91. **The Nip Comb.**—It would be needless to describe here all these inventions, and the tremendous law-suits which took place in connection with them. The combs, as they now exist, are what we have to deal with, and of these the three leading sorts are the Lister or Nip, the Noble, and the Holden or square motion combs. We will take the Nip comb first (Fig. 19). It is in two parts: the screw gill box with the nip motion, and the circle with the drawing-off rollers. The screw gill is in principle like any other screw gill box, but without draft or front rollers. The back rollers do not hold the wool, but merely pass it forwards to the fallers from a long array of cans, often thirty in number, which stand at the back and form, as it were, a long tail of wool stretching out behind. The fallers F F, which work in the box X, are curved, being lower in the centre than at the ends, and have three rows of pins in each, which are set very closely together. Underneath them is a small coil of gas pipes, with lights to warm the fallers to enable the wool to be drawn more easily through. Above the fallers is a dabbing-brush H, which works up and down by an eccentric motion, and presses the wool into the pins. The great feature of the machine is the nip N. This works backwards and forwards by the rod L, which is worked by the wheel W, and a similar wheel and rod on the other side.

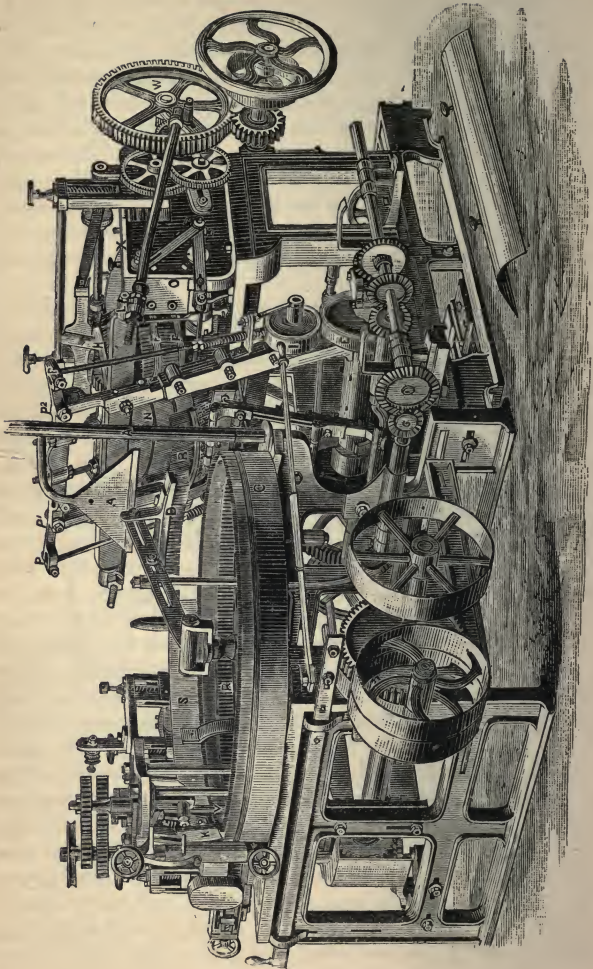

FIG. 19.



When the wheel *w* is so placed that the rod is pulled back, the nip is pressed tight against the front faller of the set, and is closed. As the rod *L* moves forwards by the rotation of the wheel, the nip moves forwards, still remaining closed, as shown in the diagram, where it is represented as about three-fourths of the way forward. When it arrives at its farthest point it is met by the carrying comb *B*, made of long thin wires, the points of which have gently touched it, just at the line where the upper and lower plates of the nip meet. The rod *L* is then again drawn back, and the nip returns with it, but now open, showing two iron plates, the top one with a rounded but thin edge, and the lower one with a groove into which the former fits when they meet. The motion which causes the nip to open and shut is at *E*, which is an eccentric tappit made with a point. When the point of the tappit is up, the circular solid pulley *I* is pressed up, raising the upright rods which rest on it, and so pressing down the nip by the action of the joints *P P P<sup>1</sup> P<sup>2</sup>*. When the point of the tappit is down, the reverse takes place, the rods *P P* fall, and by means of the joints *P<sup>1</sup>* and *P<sup>2</sup>*, each of which acts as a fulcrum, the nip opens. As the nip recedes, the carrying comb *B* moves forward and its points stroke the pins of the circle *C*; there it retires, and the dabbing brush *D* dabs twice in the circle before the comb again returns.

92. Action of the Nip Comb.—Now when the comb is charged with wool, the fallers bring it as far as they go. When a faller drops, the wool which was in it remains above and projects forwards. The nip at that moment comes up open, almost touches the fallers, and closes over the wool which has just been left by the faller which dropped. It is held very firmly in the nip, because of the thin edge and groove of the upper and lower parts respectively, and when the nip again moves forward it carries the wool along with it, drawing all the fibres, of which it has caught one end, through the pins of all the fallers. In

this way all that part of the wool is combed, the little lumps and knots being left behind in the pins. The carrying-comb being set to meet the nip just before it opens, takes on its points that part of the wool which projects through the nip, and so secures it that when the nip opens and recedes, the carrying-comb carries off the wool from between its two plates. It carries it to the circle c, and lays it gently on the pins, which are set all round, and which, indeed, form the circle. The dabbing brush d comes down, dabs the wool into the pins, and the comb being released returns again to meet the nip. The circle is all the time travelling from left to right, taking the wool with it, which is hanging like a fringe over its outside edge, between the place where the dabbing brush falls and the farther end of the plate of iron marked s. As the circle moves slowly, the comb can deposit its layer of wool so quickly that each deposit overlaps two-thirds of the previous one. The piece of sheet-iron, or tin, s, is merely placed to press the wool still farther into the pins of the circle, and at its other side are the drawing-off rollers, which draw off all the wool they can lay hold of, and pass it through a funnel to the press-rollers, and thence into a can. This is the "top," or combed wool. The very short fibres of wool which remain in the circle are taken out by knives, k, inserted in it for the purpose of lifting them out, and they fall over naturally into a box or can placed to receive them. This short wool is called "noils." The circle is driven from inside by a rack r, and a little wheel on the short upright shaft v. To guide the wool, and keep it lying straight, and then to blow it round in the direction in which the circle travels, so that the drawing-off rollers may get its points first, a blast of air is sent through funnels A A and others not shown, which can be altered according to the length of the wool combed.

93. **Chief Point of the Nip Comb.**—We have seen that the main length of the wool is combed clear by being drawn by the nip through all the fallers, but that that

which is held by the nip is not clear, and contains part of the accumulated short wool or noils of all the immediately preceding draws. To clear it, the carrying comb must throw or place it well over the outside row of pins in the circle, so that when the drawing-off rollers catch it they may draw all that part through the pins of the circle and so clear it too. This method of first clearing about nine-tenths of one draw of wool by the fallers, and then clearing the other tenth and a little more by the circle, is very simple and effective, and for long English wool there is no comb to beat it yet.

94. **Setting of Nip Comb.**—We have thus described the nip comb at some length, because the method by which various parts work must be understood to enable the overlooker to adjust them properly. It is not put together in such a way that all the parts necessarily work in harmony. On the contrary, the overlooker must set each part with the utmost nicety, or the work will be spoiled. We will now state how it must be set. The back rollers must not be tightly pressed together, their function being only to feed the fallers. The front faller must have travelled just half of its journey forward, and must not in the least have begun to drop, when the nip has reached the extremity of its backward journey and has closed upon the wool left projecting by the previous faller. This is most essential, because then the nip presses or nips as close as possible up to the front faller, and thus no uncombed wool will be left on its hinder side. The nip then travels forward again, and, going quickly, pulls the wool through the faller-pins, while the faller completes the second half of its journey and then drops. If the faller has say  $\frac{1}{4}$  inch farther to travel when the nip closes, it is clear there must be  $\frac{1}{4}$  inch uncombed wool between the two, and to clear this, the wool must be thrown  $\frac{1}{4}$  inch farther over the circle than is otherwise necessary. The two plates of the nip must fit exactly into each other, and equally all the way across, nor must the edge of the upper one be too sharp or it will cut the wool. Often, from bad management

of these two points, the nip cuts the wool as clean as if done by a pair of scissors. If it does not close tight enough, it cannot draw the wool through the fallers, and leaves paps sticking out, which have to be caught next time. The exact medium must be obtained; nothing else will do. Next the carrying comb must be set, and this is really a work of difficulty. It must meet the nip at the right fraction of a second in the right place, on the one hand, and must deposit the wool in the right place on the circle, on the other. It must press very gently against the nip, so as just to carry off the draw of wool on the tips of its teeth, and when it afterwards reaches the circle, the tips of its teeth should go rather more than half way across the rows of pins, but without pressing into them. One row of pins, the centre one often, is made longer than the rest, and this catches the wool and retains it as the comb recedes, and then the dabbing brush comes down. The distance which the comb reaches over the circle regulates the amount of noil made, the farther the wool is thrown over, the larger being the noil. The difficulty consists in getting the comb at once to throw the wool the right distance on the circle, and also to meet the nip in the right place, for it may be doing the one right and the other wrong, and only careful testing can insure that both are right. This depends entirely on the overlooker, as the position of the comb can be shifted up and down at will. The dabbing brush next needs regulating to dab twice between each journey of the comb, and always to be as high up as it will go when the comb is just going to lay the wool on the circle; if it is not, but is too low, it will knock the wool off the tip of the comb, and then it will not be laid far enough over the pins. The blast of air next must be regulated. The triangular case (Fig. 19, A), has a narrow opening along the bottom, and blows the ends of wool which are hanging on the circle downwards, to get them out of the way of the comb next time it comes. As the circle travels round, other blasts of air blow

the loose ends of the wool forward more quickly than the speed of the circle, and thus these ends are caught by the drawing off rollers, and the whole fibre is drawn through the circle; the longest ones first because they reach the rollers first, and the shortest ones last, till only the very short wool is left which, as already said, is taken out by knives fixed with their points between the rows of pins, and tumbled into a can placed for it. The drawing-off rollers can be set near to or farther from the circle according as it is desired to draw the wool close or not, but the best way is to place them near, and if a large noil is needed, rather to throw the wool well over the circle by the carrying comb. The only other detail needing mention here is that the point of the tappit (Fig. 19, E), must be at the top just after the nip motion has arrived close to the front faller. The nip, of course, must not shut till just after it has reached the faller. If it shut too soon, it cannot nip close up; if too late, it will not begin to draw the wool through the fallers just when it starts in its forward journey. The nip should make about forty journeys each way per minute, and the carrying comb, of course, the same number. Hence the double journey only takes  $1\frac{1}{2}$  seconds, which shows with what very great nicety the time of each motion has to be calculated, and how short is the interval between the nip touching the faller and closing on the wool. It is the smallest fraction of a second, but it will make the whole difference between good and bad work whether the fraction be right or wrong. There is no machine in the trade more beautiful and delicate in its adjustments, nor one whose work can be more easily spoiled by the slightest want of attention or knowledge on the part of the overlooker, and, therefore, this full description has been thought necessary.

95. **Noble's Comb.**—The Noble is very different in its structure from the nip comb, as will be seen by the accompanying drawings of the machine (Figs. 20, 21) as made by Messrs. Taylor, Wordsworth and Co., of Leeds, one of the

chief firms of comb makers. Instead of the wool being put up at the back of the comb, it is wound on to large bobbins, and placed in the circular rack which surrounds the centre of the machine (Fig. 20). These balls are made on the machine here shown. Four cans are placed behind the rings R R, and the slivers are passed through

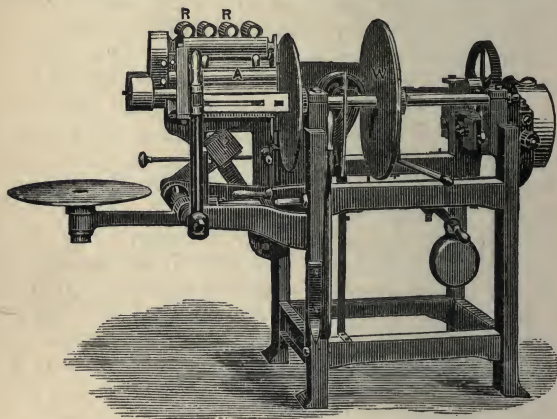

Fig. 20.

them, and through the rollers in front, on to a bobbin which lies horizontally on a spindle at A, and which is held tight between two plates. The machine is driven by a friction wheel, w, and the balls are thus made quite hard. No twist is put in, and therefore when taken to the creel of the comb they can be unwound just as they lie, and the ends drawn into the circles for combing. To make a set, 18 of these balls are needed, and they are placed on the rollers of the comb, B B, with their ends through the rings A A, in succession all round (Fig. 21). The ends then pass through Whitehead's patent feed boxes, which are made of brass with a heavy lid, the end at the back being open as shown, but the other end being closed

when they are empty. As the hinge of the lid is at the back, all its weight falls on the other end, and the wool is thus held somewhat firmly, and cannot slip backwards unless the lid is opened. There are seventy-two of

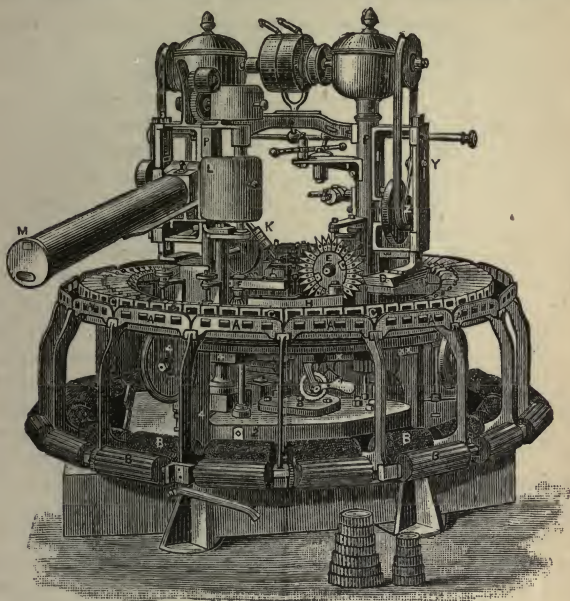

Fig. 21.

these boxes and, as will be seen, they are set in a ring. Inside this ring is a large circle, which rests on a circular steam chest to heat it; and the whole of this portion of the comb, except the steam chest, namely, racks, rings, boxes, and large circle, revolve together. Inside the large circle are two small circles, one at each side, as shown in Fig. 22, and the whole combing is done by the motion of these three circles relatively to each other. The large

circle is usually 48 to 60 inches in diameter, and the small ones 16 to 20. The width of the rim of these circles varies according to the class of wool to be combed, but in the large circle it is usually from 2 to 4 inches wide, and in the small ones from  $\frac{3}{4}$  to  $1\frac{1}{2}$  inch. They are

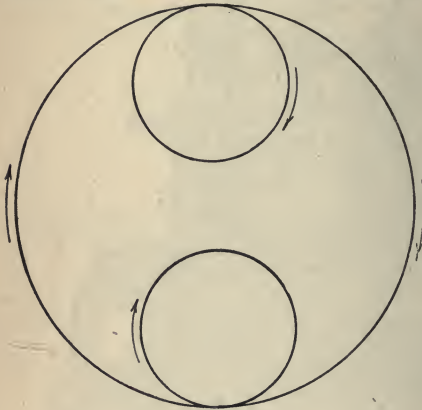

Fig. 22.

covered with rows of pins set in circles round them, and the size and number of the pins vary likewise according to the wool. For fine wool the front rows of pins in the large circle may be about 40 per inch, and in the small circles 44, while the rows at the back are

coarser. For strong wool, 18 pins per inch are enough for the large circle, and 20 for the small ones; but these numbers vary indefinitely. The three circles all move in the same direction, but the small circles almost touch the large one at one point and, revolving, leave the latter behind. It is this which combs the wool. As the carriage, *i.e.*, the boxes, racks and large circle, revolve, the wool is brought to the point of contact of the large circle and one of the small ones. By a motion to be described presently, the wool is constantly being pulled through the boxes, so that it projects over and beyond the large circle. Therefore its ends project over the small one. Just as it passes over this point, a dabbing brush (Fig. 21, D) falls on it and presses it down into the pin of both the circles where, of course, it must remain. The



little circle revolving, draws from the large one as much wool as it is able to retain of that which has been dabbed into it; that is to say, it takes all the noil and short wool from the large circle out of the particular piece of sliver, which has been dabbed in at any given moment. It leaves projecting from the large circle the ends of all the fibres of the long wool which, owing to their length, have preferred to remain behind; but in doing so it combs this projecting portion. As all the ends of the sliver have been dabbed into the little circle, and as this latter in revolving has been obliged to leave the long fibres in the large one, they must all have been drawn through the pins of the little circle, and the noil that may have been in them has been retained there; so that the ends which project from the large circle are quite clear. Similarly the ends which project from the outside of the little circle must also be clear, because they have been dabbed into the large circle, and have been drawn through it as the little one leaves it. Thus the projecting fibres which remain in the large circle have left their noil in the little one; and those which project from the little circle have left their noil in the large one, and the projecting fibres in each are combed clear. We will follow the little circle first. The wool in it now consists of short fibres, which are yet long enough to be used in the combed wool or top, and the very short fibres which form the noil. As it revolves it is met by the stoker (Fig. 21, E), a wheel with sharp teeth projecting from it, and screwed on to it. These teeth, by a patent of Mr. Whitehead's, a member of the firm of Taylor, Wordsworth and Co., can all be moved together, and set at any angle that is required. This wheel revolves from left to right, and is used to stroke the wool which projects from the little circle, so as to turn the ends forwards instead of letting them stand straight out. To do this it must revolve very rapidly. As soon as the wool has passed this, it is met by a small pair of vertical drawing-off rollers, which catch all that projects, and draw it out

of the circle, combing as they draw the ends which were formerly in the pins. What remains in the circle is noil, and is lifted out of the circle by knives, which are set between rows of pins. The noil ultimately tumbles over into a can, and is removed. The large circle in the meantime is travelling on, with its long wool projecting from it. It soon comes to a travelling leather apron, which goes quickly, and draws the points of the wool forward, acting like the stroker to the little circle. At **F** are fixed the drawing-off rollers, and the leather **H** passes round one of them. These draw off all the wool they can catch, and it passes along between another part of the leather **H** and a second leather, until it meets the short wool sliver which has been drawn from the little circle, and the two then unite. As the second little circle has been acting in the same way all the time, there are thus two ends of short wool and two of long, all of which join together, pass up the steel funnel, **K**, which puts a little false twist into them, and then through a pair of press rollers, **L**, into the long brass funnel, **M**, which carries them into a can set to receive them.

96. **Ground Plan of Noble's Comb.**—Such is the principle of Noble's comb. It is, in brief, merely dabbing a lock of wool on to two sets of pins placed close together, then parting the two sets so that a portion of the wool adheres to each, afterwards drawing the wool out of each through the pins, and again uniting the wool thus drawn to make the combed top. The arrangement of the various parts is somewhat more complicated than in the nip comb, though the relative adjustments are not so delicate; but to make it clearer, we give (Fig. 23) a plan of the comb, supplied by Messrs. Taylor, Wordsworth and Co. **B B** are the racks or creels on which the balls rest; **A A** the rings; and **C C** the boxes through which the ends pass. **D D** are the dabbing brushes to press the wool into the circles marked *large circle* and *small circle*. **H H** is the leather conducting the long wool to its drawing-off rollers, **F F**, and **N N** is

the second leather between which and HH the sliver is conducted to the steel funnel, K. E is the stroker wheel

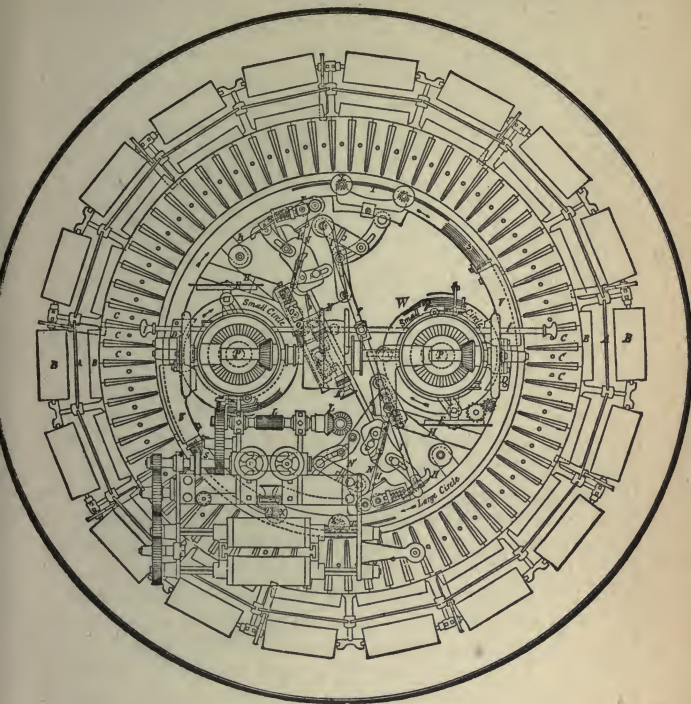

Fig. 23.

for conducting forwards the wool in the small circle, and the leather NN passes round one of the rollers, OO, which draws off the short wool from the small circle, so that the long wool really joins the short wool before the latter is drawn off. The two together then pass through the funnel, K, and the press rollers, R, to the main press

rollers, L, and out by the long brass funnel, M, which is not here shown. The noil knives in the small circles are w w. When the noil is raised up by them, it meets the plate shown across the circle, and then falls over to the outside into a can placed for it. I I is the double stopping rod, worked from a pivot in the centre, so that the machine can be stopped from any side. P P are pillars which are hollow, and contain shafts which drive the comb below. Between the pillars is a cross shaft on which are the driving pulleys, and by means of bevelled wheels this works the upright shafts in the pillars, and these work all the wheels below the bottom plate of the comb which drive the circles and all the rollers.

97. Feeding the Noble Comb.—When the wool is once dabbed into the circle at the point of contact between the two circles, it must remain in the circles until it is again lifted out. The small circle, as we have seen, is emptied by the drawing-off rollers, o o, and the noil knives, w w. But the large one when it has passed the drawing-off rollers, F F, is still full of wool, and the front ends of the boxes, c c, are on a level with the bottom of the pins in the circle. These boxes and the wool in them and in the circle must be raised, and a little more wool must be drawn through the boxes, before it can be dabbed down under the second small circle. To effect this the boxes are made to run on an inclined plane, as shown in the elevation (Fig. 21), the highest part being just before the dabbing brush is reached, after which they fall rapidly. The boxes thus rising tend to lift the wool out of the circle, but in doing this they are aided by a set of knives, s s, having a similar slope to the inclined plane, and between these two the circle is emptied. Were this all, there would be nothing to draw more wool off the balls and through the boxes. But just where the inclined plane begins below the boxes, a steel rod, T T, is placed between two of the rows of pins, and can be lowered or raised by screws set in x x. The effect of this rod is that when the boxes rise they cannot draw the

wool back from the circle, and therefore they are obliged to draw it forwards from the ball, and thus each time the boxes pass  $\tau \tau$  a little more wool is brought out. The lower the rod  $\tau \tau$  is placed between the pins the more wool is pulled off the balls when the boxes rise, and this, as we shall soon see, increases the amount of noil made. As soon as the end of  $\tau \tau$  is reached the knives  $s s$  are set, and lift the wool out of the pins. At their highest end they have entirely lifted the wool out, and it now passes over a plate,  $v v$ , placed above the pin points to prevent them from catching the wool. On this plate it naturally straightens itself out, because the part which has been pulled out by  $\tau \tau$  cannot get back through the boxes, and therefore it lies over the plate  $v v$ , and thus a fresh supply is, as it were, pushed forward to be thrown over the little circle. It is easy to see that the more there is thrown over the little circle, the more will it carry away from the large one and the larger will be the noil. Thus the noil is increased or diminished by lowering or raising the rod  $\tau \tau$ . To ensure uniformity of delivery of slubbing from the ball, Mr. Whitehead has patented a motion for the creels which makes them revolve and deliver the same quantity of sliver off the balls at every revolution of the circle, whether the balls be almost empty or full.

98. Dabbing Brushes.—The motion of the dabbing brush  $D D$  has always been a difficulty, for unless it moves up and down very rapidly some of the wool will not be dabbed down just exactly at the point of contact between the two circles. If, on the other hand, the motion is very quick, it cannot easily rise high enough, and then the wool is ruffled and rubbed sideways as it passes below the brush. The drawing of the elevation of the comb (Fig. 21) shows Speight's patent motion, by which speed is gained from the top pulley to the bottom one by a belt, and by an eccentric motion  $z$ , the brush itself is raised up and down in the case  $y$ , though the belt, of course, remains where it is. This motion gives

about 420 dabs per minute; but if the comb is heavily laden, it hardly raises the brush enough. Another and

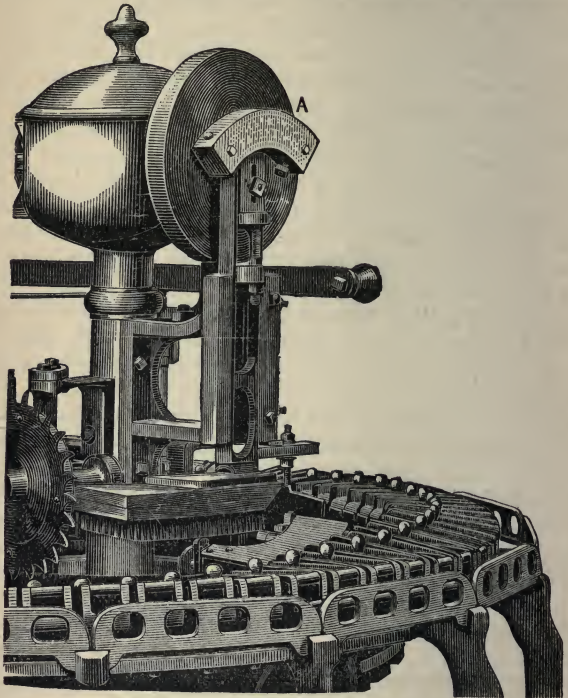

Fig. 24.

perhaps better motion is that of Hoyle and Preston, of Keighley, which, as shown (Fig. 24), works the brush entirely by the upper revolving plate or wheel A, which, while giving a vertical motion to the brush, gives a rotatory and partly horizontal motion to the rod attached to it. The motion dabs the brush 600 times a minute and yet raises it well. The wear and tear of

these brushes is very great, and as they must always be kept in good order, they are a source of great expense, but a quick dab that does not come down too hard is most economical for them. The leathers are also a great expense. The larger the drawing-off rollers the longer they will last; but for those who wish to comb near, that is, to draw the wool off quite up to the circle, small rollers must be used. At the little circle the rollers must be small, or too much wool will be left in the noil; but it is much better to use larger rollers for the long wool, and not be too anxious to draw off close. This applies, however, only to prepared wool. For wool that has been carded the drawing off can be quite close.

99. **Double Drawing-off Rollers.**—An improvement for facilitating this has been patented by Mr. Albert Smith, of Bradford, by which, as shown in Fig. 25, the drawing off is done twice. The large and small circles are A and B; the ordinary drawing-off rollers from the small circle are E E, and those for the large one C C; but in this case C C are not placed quite close to the circle, and they only draw off a portion of the wool. However much they try to draw off they will always leave a little beard still standing out. This, of course, has been combed by the little circle as much as the rest, and therefore it is drawn off by a pair of very small rollers, K K, and the sliver passes between the leathers L and M, joining the long wool sliver from C C, and both going on to join the short wool at E E. In order to turn the beard represented by the fibres at J so as to meet the rollers K K, a revolving brush, or star wheel, or porcupine roller, is placed at H, or a small comb, as shown at T, which guides the fibres forward in the same way as done by the stoker wheel. This patent, no doubt, makes rather less noil, and for short fine wool that has previously been carded it will be found useful. It has in principle long been applied to the outside of the nip comb circles, but never became popular. Mr. Smith's

patent, however, is the application to the insides of circles, though the inside of a Noble's comb circle corresponds to the outside of that of a nip comb. Where

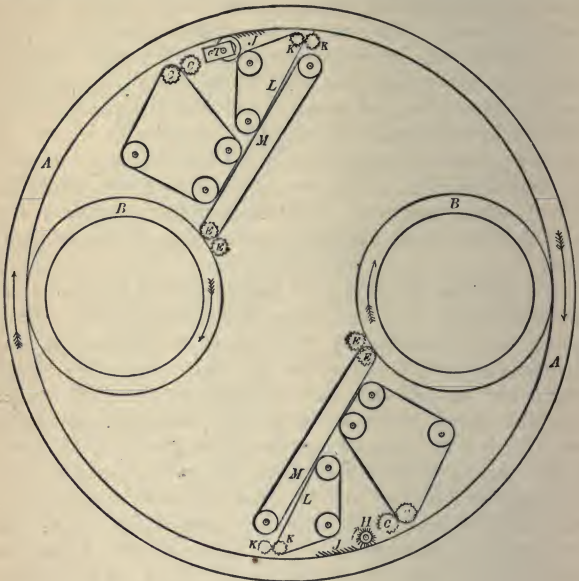

Fig. 25.

the wool has been prepared and not carded this patent would not be so advantageous, as it would be apt to draw out short staple ends which had not been properly opened out.

100. **Defects of Noble's Combs.**—Though the Noble comb is a very good machine, it has three defects which must here be pointed out. The first refers only to combing prepared wool on it, and not to carded. However well wool may be prepared, there will always be some short staples in it which have not been opened out



in the boxes. This is especially the case with skin wool. When such wool is being combed here, these short staples may very likely just fall partly on each circle; the circles divide, and the little circle may carry off the short staple, which is then drawn out by the rollers, never being properly opened, and in the same state will go right through into the top and the drawing. These may be seen by any one who combs short skin wool on a Noble comb after preparing. It is to avoid these short staples that it is well not to put the long wool drawing-off rollers too near the circle. When wool is carded, of course these are all opened, and the above remarks do not apply. The second fault is that there must always be a very small space between the two circles at the point where they meet. The brass plates the pins are set in may actually touch, but there is sure to be a small space between the pins of each. For very fine work the evil of this is that that small part of the sliver which is dabbed between the circles never gets combed at all, and may contain noil knots. This evil is greatly increased when the dabbing brushes are not in good order, for then the wool is never properly dabbed down, and it springs up, and noil knots are dragged over the pin points, with the inevitable result of bad work. The third fault is that the less noil there is made the less weight of wool is combed. It was shown that the more the rods T T were pressed into the circle, the more wool was dragged through the boxes off the balls; and therefore, the more there was to throw over the little circle, the more noil was made, and thus the faster were the balls used. Reversing all these, it is clear that the less noil is made the less quickly must the wool be dragged off the balls, and so the slower will the balls be used, and thus less wool will be combed. This is a great drawback, but it seems, like the other two, unavoidable. If any one can alter it, he will increase the usefulness of the comb greatly. In spite of these faults, however, the Noble combs are supplanting the nips, and the latter will be only used for the longest classes of English wool.

101. **Holden's, or Square Motion Comb.**—The third, and for fine Botany wool, the best comb, is the Holden's or square motion comb, which owes its leading features to the mechanical genius of Mr. Isaac Holden, M.P. Much could be written regarding the varied mechanism of this comb, but a general outline must suffice. The two drawings given of it (Figs. 26, 27), as made by Mr. John Perry, of Shipley, near Bradford, show it from opposite sides standing empty. The wool is placed in balls or cans on the floor behind the rollers A, which receive it in two thick slivers. One of these is placed between the second feeding rollers B B, which work at a slow speed. Projecting from these are brushes, C C, and the sliver, as it passes through the rollers B, lies just under these brushes. The two pairs of rollers B B work on the same shaft, but on two large eccentric wheels placed at E, which make them move backwards and forwards alternately, as if a man were beating the air by throwing out his arms forwards one after the other. Their object in doing this, however, is to comb the wool on to the main circle D. The front of the roller comes very near to the circle, lays the wool on it by the brush C pressing it down, then retires, drawing the wool it carries through the pins of the circle, and consequently leaving one combing of wool in it, with the noil projecting in the inside of it. As the circle revolves, fresh layers of wool are placed on it; so that a continuous fringe is carried round. This is the first combing operation, and clears the wool of all its larger knots. The circle is made with only two rows of pins, one very fine at the front, and one coarse behind. It travels round till it comes to the pressing-knife and square motion. The former is a double plate of thin steel, which works up and down, pressing the wool into the front row of circle pins, one plate being in front and the other behind. It is worked with much strength of pressure by a motion similar to that which works the nip of the nip comb, and it presses very tightly down on to the brass of the circle. In consequence of the action of the spring K the

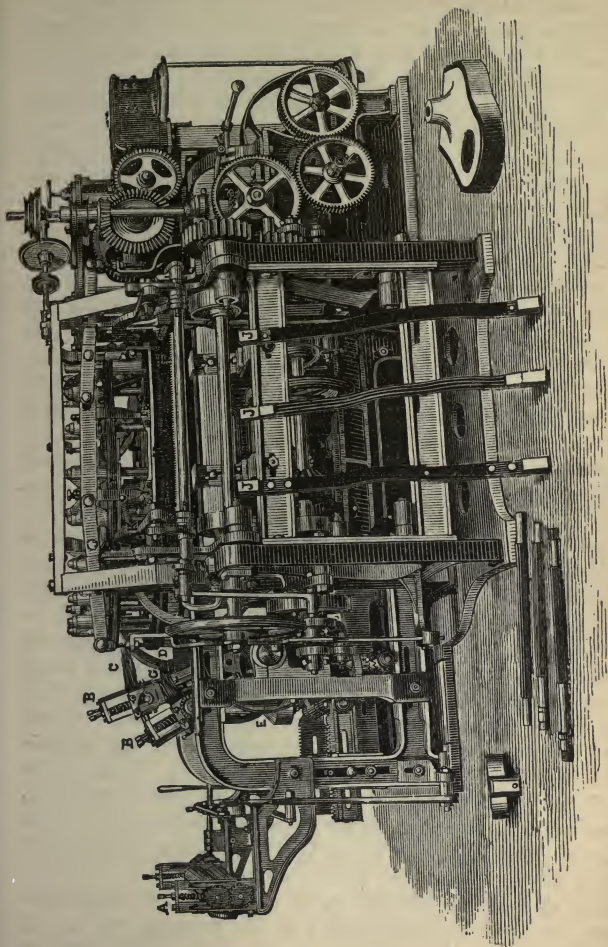

Fig. 26.

pressing plate is carried forward with the circle a couple of inches or so, and thus there is no danger of it cutting the wool as there would be if it were stationary and let the wool slip under it. During this time the square motion is acting. This is simply a set of seven fallers, straight at the ends, but with a concave curve in the middle to fit just into the convex curve of the circle. These fallers are alternately 3 up and 4 down, and 4 up and 3 down. They are rather more than an inch wide, and covered entirely with steel pins set as closely as possible. As each rises up it receives on its pins all the wool which was projecting outside the circle. As the fallers rise at the rate of about 100 per minute, their pins pass rapidly through the wool and comb it as they travel. The brush H is on a rocking shaft with an eccentric motion, the result of which is that it keeps brushing the wool over the faller points. The brush and fallers would indeed carry off all the wool from the circle were it not for the pressing-knife, which holds it back. As it is, all the wool, except just what is in the circle and close to it, is combed, and drawn through the faller pins F F. The fallers work in a manner similar to those in a gill box, though the mechanism is entirely different, and those at the top, of course, travel away from the circle, as they comb the wool held in it at the same time. The noil and other fibres which the fallers have combed out are removed from them by a little comb as they drop, and as these accumulate, they are tumbled over the rod at the back into a can, and are at once recarded. Three fallers, J J J, are shown in Fig. 26, reared up against the comb, and the curve in the centre to fit the circle will be seen. A very important part now comes into operation, namely, the intersecting comb, L L L. The object of this is to secure the perfect combing of that part of the wool which lies close to the circle on the outside, and which the fallers of the square motion have not been able to reach owing to the pressing knife. It is much the same as in the Noble comb, where there is

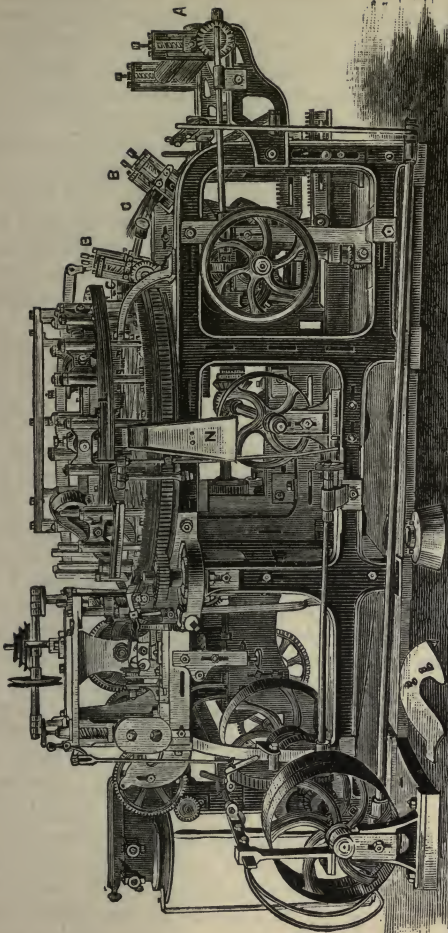

Fig. 27.

always a little space between the large and small circles which never gets combed at all. By the intersecting comb, however, this defect is easily remedied. It is made in sections of about a foot long, and travels all round the comb, for about three-quarters of the time being raised up on a high slide and steam chest, thus allowing it to clear the circle when the feeding rollers and pressing plate are at work. But as soon as the sections of this comb reach the right hand extremity of the high slide, they begin to descend, with the points of the pins downwards, and projecting slightly beyond the outer row of pins in the large circle, so that by the time any part of the main circle is opposite the drawing-off rollers, a part of the intersecting circle is between the two. To get the full benefit from this, the wool is pushed from the bottom of the pins of the main circle nearly to the top, and it thus enters the pins of the intersecting comb. This is done by a small vertical rod which moves quickly up and down with a plate on the top of it; it simply pushes the wool up from the pins of the main circle. The drawing-off rollers then catch all the wool they can and draw it off combed. It has really gone through three combings. First, when the feeding rollers B and brush C combed it through the main circle; second, when the fallers of the square motion combed all the fringe which lay outside the circle; and third, when the drawing-off rollers caught the wool thus combed, and drew the remainder through the pins of the main circle and intersecting comb. By this means every part of the fibre is thoroughly combed.

102. **Bailey's Noil Motion.**—The drawing-off rollers are variously made. In Figs. 26 and 27 they are concealed by heavy wheels which are now no longer needed; in other combs they are driven in a much more open way; but they are merely simple rollers with a coiler attached for very short wool. The circle now passes the rollers and the intersecting comb has to rise again, as shown by L<sup>1</sup>, in Fig. 27, to its higher level. Before it does so a little comb, not here shown, combs

all the noil out of it back on to the main circle, so as to have the former quite free of noil for its next round. The noil is then taken out of the circles by knives, and drops down the slide into a can. A great improvement has, however, been made at this point by Mr. Isaac Bailey, commission wool comber at Keighley; it makes much less noil than any other comb can work with, and yet the clearness of the top is no way affected, because it has all been drawn off previously. At about the place where the slide *n* is placed Mr. Bailey has another circle of one row of pins revolving in the opposite direction from the large circle, thus (Fig. 28), but turned upside down, that is, with the pins pointing downwards, and just set so that they are exactly above the pins of the large circle. A little comb works up and down quickly, and pushes the noil from the large circle on to the small one. The position of the noil is now reversed.

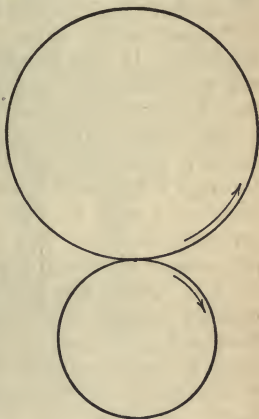

Fig. 28.

What was outside the large circle is inside the small one, and *vice versâ*; consequently all the long hairs which inevitably remained outside, or at the back of the pins of the large circle, are now outside the little one. These are caught and pulled off quite close to the circle, and thus separated from the noil, in which nothing is left but the very shortest fibres. These in turn are combed out by a vertical comb moving quickly up and down, and fall into a can. The longer hairs previously drawn off are carded over again and next time may pass into the top. This ingenious invention, which is patented, reduces the noil by one half when wool of

four or five inches long is being combed, but when the material is very short Botany, the advantage is not so great.

**103. Advantages of Holden's Comb.**—This comb, though at first appearing complicated, is very simple in its working and not liable either to accidental stoppages or to wearing out quickly. It is also less expensive to keep up than a Noble comb, as it has not the small drawing-off leathers, and its one brush (Fig. 26, H) does not wear out nearly so fast as the two dabbing brushes of the other machine. It also requires less power to drive it. It is not well suited for long or even medium wool, and therefore is not so much used in the English worsted trade as the Noble. It is confined to commission combers and Botany spinners. If long wool were to be dragged through the pins of the square motion fallers, the power required would be very great, and the fibres would be seriously broken. But there can be no doubt as to its advantages for Botany wool.

**104. Other Combs.**—There are also other combs, notably Messrs. Little and Eastwood's, made by Platt Brothers, and much recommended by them. Heilmann's comb is largely used in France for very short Botany, but is not popular in England; it has the merit of being very small and light, and of doing thoroughly good work. There is also a little-known comb, made by Mr. King, wool comber, of Bradford, which is well adapted for combing short wool such as East India; but all these and others it is impossible, within the limits of this book, to describe.

**105. Balling or Top-Making.**—One other process follows combing which all systems have in common, namely, balling, or making into "tops." After leaving the comb, the slivers are put up at the back of a can gill box to be straightened and levelled, and the cans from it are put up at the back of the balling box. This, as will be seen from Fig. 29, is an ordinary gill box; but instead of the sliver running into a can, it is wound



on to a ball, which is made on a bobbin lying between the upright guides, A, and on the rollers, B. As this balling head moves from side to side quickly, the ball is made by the sliver constantly passing from side to side. Some spinners, who are very particular, wind their

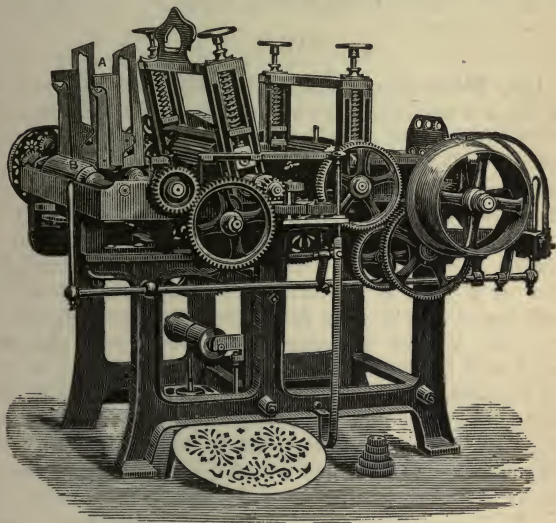

Fig. 29.

combed wool direct on to large bobbins instead of on to balls, which has the advantage of keeping it much smoother. It is, of course, a much more expensive way at the beginning ; but whatever tends to make work better in quality and to prevent waste is a distinct gain and should, if possible, be adopted.

## CHAPTER VII.

## DRAWING.

106. **Principle of Drawing.**—After combing, the next operation is drawing. There are three principal methods of drawing: open drawing, cone drawing, and French drawing. The first can be used for either long or short wool, according to the style of machines and sizes of their rollers, &c.; the other two are only used for short wool or, at the most, wool of medium length. The principle of drawing is very simple. It is merely to reduce a thick sliver or a number of slivers of wool down to one so small that it can be spun into a thread without an excessive draft, and at the same time to level it so that the thread will be all one thickness. This is done, and can only be done, by a pair of back rollers revolving slowly drawing the wool in and feeding a pair of front rollers which revolve quickly, and which draw the wool out. This operation is repeated a sufficient number of times, with an appropriate number of doublings, till the wool is brought down to something like a pith, called the roving, when it is ready to be spun. All sorts of drawing do this, but there are other differences in their methods which require our attention.

107. **Drafting Twice the same Way.**—In addition to the principle of drawing which is common to all methods, there is a point which is of importance alike to all, regarding the direction in which slivers of wool should be drafted. When the overlooker receives his tops, or balls of combed wool, which may either be all one quality, or mixed as may be needed for any given sort of yarn, he first unwinds them into cans, and it is necessary that they should be unwound from the centre and not

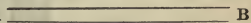
from the circumference, so that they may be drafted in the opposite direction from that in which they were drafted by the balling box. It must be remembered, as the first elementary rule in drawing, that a sliver must never be drafted twice running in the same direction, *i.e.*, with the same end first; for if this be done it will run the risk of being more or less twitted, or alternately thick and thin. This seems very curious at first, but the reason is clear. Take two straight lines A  B to represent any length of slivers, say 50 yards. These are passed through a box, either with or without fallers, and drawn out with the ends A first, and with 6 of a draft into 300 yards of sliver, just one-third of the thickness of either of the original two. Draw this one again, still with the end A first, and again with 6 of a draft, and it will give 1,800 yards, or 36 times the original length of 50 yards. Therefore, it is just the same in effect as putting 36 of a draft into the first box and drawing it all at once. Such a draft would, of course, be too much for any wool and would make the sliver twitty. But if in the second box the end B is put first, the end will come out to 1,800 yards perfectly smooth and level, because it is drafted in the opposite direction each time. It has, no doubt, still been drafted to  $\frac{1}{36}$  thickness of what it was at first, but the pull has not been all one way of the fibres; there has been a pull of 6 one way and of 6 the other, and the fibres have, relatively to each other, moved first forwards and then backwards instead of very violently all forwards. It is the moving back again in the second drafting that keeps the sliver level; and, therefore, the tops must be unwound into cans from the centre, so that the outside end may go through the can gill box first. If, instead of using cans, the tops are unwound from a creel, which many prefer, they must be unwound from the outside, as in this case the end of the sliver is fed directly into the gill box from the top.

108. **Open Drawing.**—We will take first open drawing for ordinary English wool from 8 to 12 inches long.

It consists usually of six operations : (1) the can gill box ; (2) the spindle gill box ; (3) the 4-spindle drawing box ; (4) the 6-spindle weigh box : (5) three 6-spindle finishing

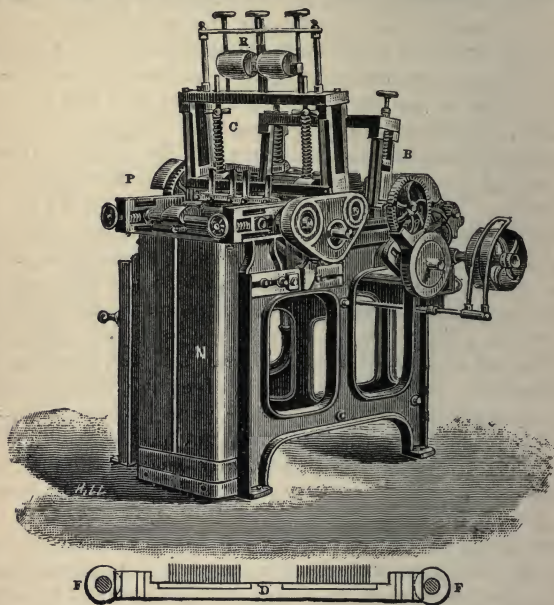

Fig. 30.

boxes ; and (6) the dandy roving boxes arranged in any number of spindles and boxes that are convenient.

The set of drawing machines, of which we give diagrams (Figs. 30—32), is as made by Prince Smith and Son, of Keighley, and is of the best construction. The can gill box here shown (Fig. 30) is a double one ; that is, the fallers are divided as shown below, the can, N, is also divided up the middle, and the rollers, B, C, and R, are in double sets, and also the press-rollers, P. Five or six tops are put up at each half box

and drawn through the box, precisely in the same way as in the preparing gill boxes, formerly described at length. They go in at the back rollers, B, travel forwards in the fallers, of which F F is one, are drawn out by the front rollers, c, and pass through the press-rollers into the can. The top rollers, R, are for leather aprons to run round. The front rollers, c, both top and bottom, are made of iron. If they ran uncovered as the back rollers do, their greater speed would make them cut the wool, and wear themselves out. An endless leather sheet must, therefore, run between them, and round one of them. In preparing boxes it always runs round the bottom one, its other extremity runs round a wooden roller below ; but in this and the next box the leathers run round the upper rollers and also round R R, as being the more convenient position. In some boxes, instead of the upper iron roller, c, and the wooden one, R, there is a large heavy solid roller, covered with leather ; but the box as here shown is the best, as it is possible by it to get the nip of the rollers closer to the fallers than in the other way.

109. **Two-Spindle Gill Box.** — The second box (Fig. 31) is similar in every respect save one, and that is that the sliver when drawn through the rollers is wound on to two large bobbins 14 inches by 9 inches of inside measurement. In the gearing of wheels and method of finding out and altering the draft, these two boxes are just like preparing boxes, but in their working there is one important difference. There must be no draft between the fallers and back rollers. If there were, the end would not be so even, especially if a short top be mixed among a number of long ones. The back rollers should be set back some way from the fallers, the distance depending on the length of the wool, and the wool should just be tight enough to lie nicely in the pins without being stretched. All the draft is done by the front rollers. As the sliver is wound round the bobbin a little twist is put in by the flyer,

which is a cross bar with two side wings hanging down, and is fixed to the spindle. The sliver passes through a

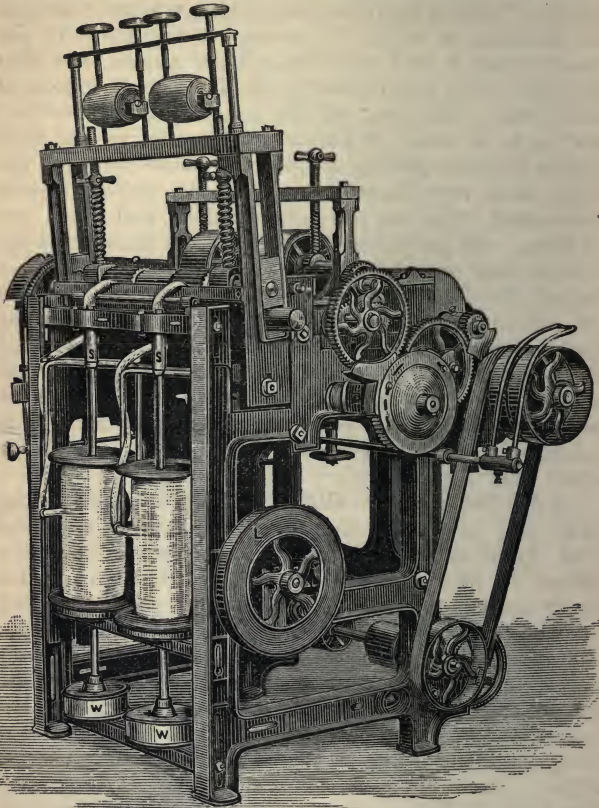

Fig. 31.

ring at the top of the vertical part or wing of the flyer, is wound round one of the wings once or twice to lessen the drag, and then passes through another ring on to the

bobbin, as shown. The twist is regulated by the speed of the spindle relatively to the speed of the front rollers; the faster they deliver the end of sliver the less twist can the spindles, at any given speed, put into it. The spindles are driven by belts round *w w* from a shaft seen at the back of the box. The amount of twist needed for this thick slubbing, as it is now called, is very small, a fraction of a turn per inch being enough. The slubbing should be strong enough to pull out easily when stretched by the hands. Of course, strong loose wools, and wool with no oil on, need more twist than fine wool, or wool well oiled.

110. **Varying Speed and Drag of Bobbin.**—The bobbins move up and down the length of the spindle on a lifter-plate worked by the “mangle wheel” *L*, and are thus evenly filled. This lifter, in all the operations of *open* drawing, goes at the same speed in any given box, no matter whether the bobbin be full or empty. Therefore, there is just the same length of slubbing wrapped round an empty bobbin for each rise or fall of the lifter as round a full one. But the diameter of the barrel of an empty bobbin is in this box three inches, while the diameter of the bobbin head or of a full bobbin is 9 inches, the respective circumferences being 9·4 and 28·2; therefore a full bobbin must revolve faster than an empty one, to let its greater circumference keep up with the rate of delivery of the slubbing. Between these two points the speed is constantly increasing. If the speed did not increase from what it is at first, the slubbing would break in its effort to get round the greater circumference in the same time; but instead of that, it drags the bobbin (which is quite loose and free on the spindle) round with it. By watching a box running this will be seen in a few minutes; but the point is worth noting here, and we shall refer to it again when considering cone-drawing, the object of which is to regulate the drag and speed of the bobbins. To regulate the drag of bobbins in open drawing, large cloth washers are put between the bottom of the bobbin and the lifter-plate. The larger

these are the heavier the drag. Also the heavier and fuller the bobbin, the greater the drag, because the greater weight makes greater friction at the bottom. Therefore, as the bobbin becomes fuller, it both goes faster and yet

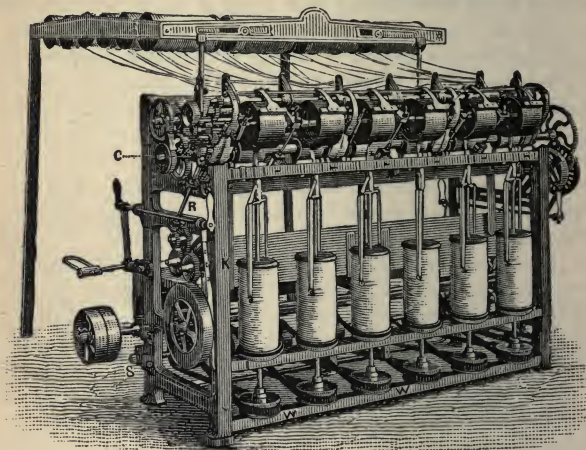

Fig. 32.

offers more resistance to its motion. For very short loose wool this is a great drawback, and it is to remove this defect that cone-drawing is often used.

111. **Open Drawing Boxes.**—The third, fourth, and fifth boxes are very similar to each other. A drawing of the fourth is given in Fig. 32.

Five bobbins are taken from the second box and put up in the creel at the back of each spindle of the third box, and the five ends are drawn out into one rather thinner than any of the five. Four of these are taken and put up per spindle at the fourth or weigh box here shown, and drawn again into one still thinner. Four of these are again taken to the back of the finisher and drawn into one thinner still, and two of these finishing bobbins are finally put at the back of the rover, and drawn into one



thin roving ready for spinning. All these drawing-boxes differ from the first two in having no screws and fallers; they have only rollers, back and front as before, and two rows of carrier rollers in between, which steady the wool, and run a very little faster than the back rollers, but have nothing to do with the draft. The draft is direct from the front rollers to the back ones. The top front roller is solid and covered with leather, and the bottom ones instead of being deeply fluted are nearly smooth, but with shallow little flutes cut in them. The method of altering the draft is the same as in spinning frames, and will be discussed at length when we come to them; we need only say here that it is altered by changing the speed of the back rollers, and not that of the front ones. The change wheel at the end of the front roller shaft is a driver, driving the back roller wheel by an intermediate wheel. The larger it is the more speed will the back roller obtain, and if the back roller goes faster while the front roller is the same, there will be less draft. Therefore a larger change wheel gives less draft to the box, but more speed to what it drives, viz., the back rollers. The danger of confusing drafts and speeds is great. Overlookers are too apt simply to remember that for the change wheel "more gives less," without thinking of the principle on which it works. In these boxes the exact twist does not matter; it is better to be guided by feeling how easily the slubbing will stretch than by counting the exact fraction of a turn per inch; it is usually altered by changing the wheel on the twist pulley, but it can also be altered by changing a wheel on the lower back shaft, which drives the spindles by the pulleys w w.

112. **Knocker-off Motion.**—The most important point in these three boxes is the length of slubbing put on to the bobbins at the 4th or weigh box. At the first or can box, the length is also regulated and fixed, and the cans weighed and balanced; but here it is done more closely. The apparatus by which it is regulated is at K. On the front roller is a worm-wheel with a toothed-wheel, say a

17, being turned by it at the rate of one tooth for each revolution of the roller and worm. This wheel is on the little shaft R, at the lower end of which is another worm, which revolves once for each revolution of the 17 wheel, *i.e.*, once for each 17 revolutions of the front roller. It drives a 60 wheel. This 60 has on its axis an 18 or any other wheel (for it is the change wheel), and this drives another 60, through a single stud intermediate wheel, which does not affect the matter. On this last 60, which is called the "knocker-off wheel," is a catch which, when it reaches a certain point, acts on the stop-rod of the box, and throws the belt on to the loose pulley. This it does after one complete revolution. To find the length of slubbing delivered during one revolution of this wheel, we must classify together in one group those wheels, &c., which, if increased, would cause it to run at a greater speed; and into another group those which, if increased, would cause less speed. The former are "drivers," the latter "drivens." We find the two worms and the 18 are "drivers;" for if the worms were increased into double worms, *i.e.*, turning the wheels in them two teeth per revolution, they would give more speed. The 17 and two 60's, if increased give less speed, and are "drivens." The front roller, which we will take at 5-inch diameter, if increased in circumference, would give greater length of slubbing per one revolution of the knocker-off wheel; diminishing the speed of the knocker-off and the other "drivens" will also give greater length of slubbing. Therefore the calculation stands

$$\frac{17 \times 60 \times 60 \times 15.7 \text{ in.}}{1 \times 1 \times 18} = 53,380 \text{ in.} = 1,482 \text{ yds. } 2 \text{ ft. } 4 \text{ in.}$$

on each bobbin. The bobbins are all previously made to weigh alike, and therefore any difference when full is due to irregular slubbing, and the bobbins are weighed and paired to make them as nearly alike as possible. This weighing is often done in another box as well, and it certainly cannot be done too often to ensure good level yarn.

113. Roving and Size of Bobbins.—From the finishing box the bobbins are taken to the roving boxes, and two ends are drawn into one; the operation

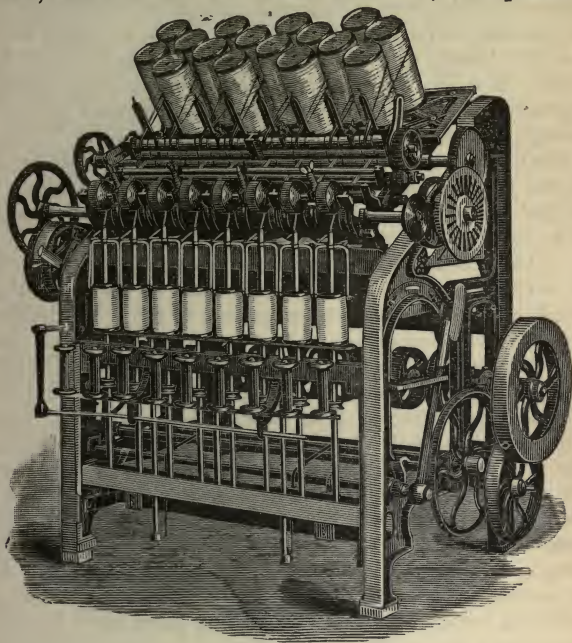

Fig. 33.

being just the same as in the drawing. As the bobbins are small, 6 in.  $\times$   $3\frac{1}{2}$  in., sometimes as many as 30 are put in one box or frame, but this is merely a matter of convenience. In Fig. 33 there are only 8. The finishing bobbins are in this case put on pegs instead of on a creel. The twist needed for rovings depends on several things. If they are to be spun new, more is needed than if they are to be laid aside for a

time, as they become stiff with age. Small rovings need more twist than thick ones. About one turn per inch is a common amount of twist ; but no rule can be given. The sizes of bobbins for English wool, except the very shortest, are usually as follows : Second box,  $14 \times 9$  ; third box,  $14 \times 9$  ; fourth or weigh box,  $12 \times 8$  ; finisher  $11 \times 6$  ; rover,  $6 \times 3\frac{1}{2}$ . These two last can be very largely increased with great advantage for all counts of yarn except the finest, and for thick counts (*i.e.*, 20 and below) the larger they are the better. For all these boxes the bottom front rollers are usually five inches in diameter, but for long lustre wool they are often six. For short wools they are three or four inches.

114. **Botany Open Drawing.**—The principles on which Botany wool is drawn are just the same as the foregoing, but there are nine operations instead of six. The following are the dimensions and number of boxes of the newest sets of Botany drawing made by Prince Smith and Son:—1st, two double can gill boxes ; 2nd, two two-spindle gill boxes ; 3rd, four-spindle drawing box, bobbins,  $14 \times 9$  ; 4th, six-spindle weigh box, bobbins,  $14 \times 8$  ; 5th, eight-spindle drawing box, bobbins,  $14 \times 7$  ; 6th, two eight-spindle drawing boxes,  $12 \times 6$  ; 7th, two 24-spindle finishers,  $9 \times 4\frac{1}{2}$ , or  $8 \times 4$  ; 8th three 30-spindle reducers,  $6 \times 3\frac{1}{2}$  ; 9th, nine 30-spindle rovers,  $5 \times 3$ . This is a large set quite complete. It is necessary to have a great many reducer and roving spindles, because for any fine Botany yarn, such as 60's and above, the rovings must be very small ; indeed, it may be said that the spinning is partly done in the roving. The front rollers of these boxes are 3 or  $2\frac{1}{2}$  inches in diameter as may be required, and the entire set is on a lighter scale than for heavy English wools.

115. **Drawing without Gills.**—In both these sets of drawing there are gill boxes for the first and second operations, as they are better for mixing the different sorts of tops that may be used than are "open boxes," *i.e.*, boxes without screws and fallers. For certain classes

of work, however, these boxes are dispensed with, and open boxes used throughout. The sorts referred to are low carded wools for coarse carpet yarn and knickerbocker yarn, a class of yarn which a few years ago was largely used, and was made by mixing silk noils with combed wool, by means of passing them through a card. Now these two sorts, though very different, have this in common, that they are filled with short fibres of noil, the former being, of course, full of its own short wool, or noil; and the latter of silk noil. If the ends of the carded balls of these sorts are passed through gill boxes, the slivers which come out will be marked in bars across with accumulations of noil; because as the rollers draw the wool out they act like the nip of the Lister comb, drawing the wool through the fallers, and leaving the noil behind; and so when each faller drops it leaves its own accumulation of noil, while the space between it and the next is comparatively clear. By putting very little draft in the boxes, this noil can be reduced to small dimensions, but it always remains, and tends to cause lumps in the yarn. By using open boxes entirely all this plucking is prevented, and the silk noil and short wool remain relatively just in the places they occupied when the carding was taken from the card. Care must be taken not to put much draft in at first, because the fibres are not straightened out, but are lying in all directions as they are carded. Without gill boxes they never get quite so well straightened all the way through, but the gain in the even distribution of the noil much more than compensates for this. For low carpet yarns this method, with small front drawing rollers, will be found very successful. If, however, it is desired to have something to support the wool, some spinners prefer "porcupine rollers," which take the place of the bottom carrier. These are small brass rollers studded with pin points of such length as the class of work may need, but usually about a quarter of an inch long. They are set as close as possible to the nip of the front rollers, and the wool

travels over them, lying in the pins. They are practically endless fallers, for they hold and support the wool like fallers, but being made in rollers there are no gaps such as must occur between each faller. By this method the plucking of slivers full of noil can be also avoided, and yet the short wool can be supported up to within a very little distance of the nip of the rollers. These porcupine rollers, as we shall see later on, are an essential part of "French drawing." Whether open drawing or porcupines be used, the other operations of the drawing are just the same as previously described.

116. **The Ratch.**—There are three points which a drawing overlooker must always keep mainly in view. The first is to have a level slubbing or roving free from lumps and twits; the second is to have the ratch of the boxes set at a suitable length for the wool; and the third to have the twist right. Of this last we have already spoken, and need say no more. The first depends on the second almost entirely, though by too heavy a drag short wool may be made twitty. The ratch is altered by moving the back rollers nearer to, or farther from, the front rollers. The rule generally given is to measure the wool in the top and set the ratch of the drawing boxes to the length of the longest fibres, so as not to break them, for in every top the length of wool differs several inches. This is a very great mistake. It is, of course, undesirable to break any fibres where it can be helped, and it is a good thing to have all the wool of as nearly one length as possible to make a level yarn. But when part of the wool is long, say 12 inches, and the bulk of it from 10 to 8, the only way to get a sound level roving is to break the long wool, and work at the average length of the lot. Therefore in the third box the ratch should be set at 11 inches for such wool; in the fourth box at 10 inches; and in the finisher and weigh box at perhaps  $9\frac{1}{2}$  inches. This is contrary to many preconceived ideas, and to much rule-of-thumb teaching; but it is, nevertheless, the right way, for what is lost to the spinning

properties of the wool by breaking the long fibres is gained in freedom from twits, for no yarn can spin well when it is twitty. If the ratch is set at 12 inches to suit the long wool, and gradually worked down to 11 only in the roving, then the larger number of fibres in the slubbing can not be held by either back or front rollers; thus, if the ratch be 12 inches and some of the wool be 8, the short fibres must travel 4 inches after they leave the back rollers before they are caught by the front ones, and have thus no support to prevent them from being drawn too quickly through by the front rollers when caught. This defect can never be wholly remedied, and all we can do is to reduce our ratch a little to prevent it from being serious.

117. **Amount of Draft.**—The amount of draft put in is also a point to be watched. A common rule is to put in one of a draft more than the length of the ratch,—*i.e.*, if the ratch be 11, put in 12 of a draft. This may serve as a basis to work on, but is really no guide. Long lustre wool will stand a very great draft, short wool must have but little. The rovings should not be made too thick. They are the cause of many bad spins and of uneven yarn, and it is better to err on the side of making them too small. To get a level roving have as many doublings as possible. The following are usually found a good number of ends to put up at the backs of the six boxes used in succession: 6, 6, 5, 4, 4, 2, These all multiplied together give 5,760 doublings. In Botany with nine operations the numbers may be: 8, 6, 5, 5, 5, 4, 3, 2, 2, which are equal to the enormous number of 288,000. When it is remembered that there have been at least two doubling operations between the comb and the top of say 10 and 6 ends respectively, the total doubling from comb to spinning amounts to 17,280,000.

118. **Calculations for Draft.**—Besides these various points, it is necessary to know how to work a set of drawing by calculating all the drafts required, beginning

at either end to obtain a desired result at the other. Given the weight of 40 yards of roving to be 10 drams, and the number of ends put up at the back of each box, and the draft for each box, it is required to find the weight of 40 yards of sliver in the can after the first box. It is more usual to proceed in this way backwards to the can than forwards from the can to the rovings, because, according to the counts of yarn required, the desired weight of roving can be at once determined, and therefore it is necessary to find the weight of the sliver. The rule is to multiply the weight by the draft and divide by the number of ends at the back of the box. The following calculation *in extenso* shows it :

	10 drams weight of 40 yds. roving
	8·5 draft of rowing box
Ends at roving box . . . 2	) 85
	42·5
	8 draft of finisher
Ends at finisher . . . 4	) 340·0
	85
	8 draft of weigh box
Ends at weigh box . . . 4	) 680
	170
	7 draft of drawing box
Ends at drawing-box . . 5	) 1,190
	238
	7 draft of 2 spindle-box
Ends at 2nd spindle-box 6	) 1,666
	16 ) 277·7 drams in 40 yds. can
	17·3 oz.    "    "    "

Now 510 is a good number of yards in a can, therefore we say, 40 : 510 :: 17·3 : 220·6 oz., or 13·7 lb. in each of the two divisions of the can. The draft of the can box is then set to give this, and it can be tested by weighing 40 yards till the correct weight is obtained.

119. **Test of Calculations.**—To test this in the operation, and see that the weight of sliver here found really



gives 10-dram rovings, a test may be taken the other way:—Weigh 40 yards off the third box, then always multiply by the ends at the back, and divide by the drafts, and the result is as follows:

	170	
	4	Ends at back of weigh box
Draft at weigh box	8 ) 680	
	85	
	4	Ends at finisher
Draft of finisher . .	8 ) 340	
	42·5	
	2	Ends at roving
Draft of roving . .	8·5 ) 85·0	
	10	Drams, weight required.

The shortest way to state these sums is the same as in taking drafts to multiply all of each denomination together and divide by the proper one, thus:

$$\frac{10 \times 8\cdot5 \times 8 \times 8 \times 7 \times 7}{2 \times 4 \times 4 \times 5 \times 6} = 277\cdot7.$$

$$\frac{170 \times 4 \times 4 \times 2}{8 \times 8 \times 8\cdot5} = 10.$$

From these two examples the principle will be seen and any other weights may be found.

120. Gauge points.—If in doubt as to the weight of roving required for a given count of yarn which must be spun—say, 30's—take a suitable draft, say 12; then divide the number of yards in one hank (560) by the proposed draft, and the number of drams in a pound (256) by the counts of the yarn required; then the quotients respectively will be a certain length of roving for a certain weight, and these can be reduced to a more convenient standard if need be. Let  $D$  be the draft, and  $c$  the counts; then  $\frac{560}{D}$  is to  $\frac{256}{c}$  as the length of roving is to weight of the same; e.g.,  $\frac{560}{12} = 46\cdot8$ ;  $\frac{256}{30} = 8\cdot5$ , or  $46\cdot8$

yards of roving weigh 8.5 drams ; as these are awkward numbers, we can say, As 46.8 : : 8.5 : 40 : 7.26 drams.

As 40 is the fourteenth part of a hank of 560 yards, it is a convenient number to work with, and does not cause so much waste in reeling to test weights. The simpler method is to use what is called a "gauge point," which is a fixed number obtained by condensing, as it were, the fixed quantities in the previous long process and the length chosen, and extracting from them their result. For example : instead of the above double calculation to get the weight of 40 yards of roving, we can use the gauge point for 40 yards, which is obtained by multiplying 256 by the length 40, and dividing it by 560 yards in a hank. Thus :—

$$\frac{256 \times 40}{560} = 18.3.$$

Then using 18.3 instead of its longer equivalent, and having the counts 30's and draft 12, we have :—

$$\frac{18.3 \times 12}{30} = 7.3,$$

which is the weight of the roving required. In other words, the draft multiplied by the gauge point equals the count multiplied by the weight of the roving ; and if any three be known the fourth can then be obtained. Another way of getting the gauge point is to divide 560 yards in a hank by the length chosen, say 40 ; and then divide 256 drams in a pound by the quotient, which in this case would be 14, and the answer, 18.28, or 18.3, is the gauge point for 40 yards. We shall refer to these rules again when treating of spinning, for they are as applicable to spinning as to any of the boxes in the drawing. The 40 yards is an arbitrary length, and may be altered at pleasure. The gauge point for 80 yards would be 36.6, and so on.

121. **Corresponding Speeds of Boxes.**—The following two rules will enable a drawing overlooker to tell whether his different boxes are running at corres-

ponding speeds, so that any one may properly supply the next succeeding one, and also will show whether the drawing is keeping the proper number of spinning spindles in work for the rate at which it goes. To tell what number of revolutions the front rollers of box A must make to supply the back rollers of box B, let A be a 4-spindle drawing-box with 5-inch front rollers, and B a 6-spindle weigh-box with  $2\frac{1}{2}$  inch back rollers, making 12 revolutions per minute, and with 5 ends at the back of each spindle or head. Then multiply the diameter of B's back roller, its revolutions, and the total number of its ends at the back together ( $2\frac{1}{2} \times 12 \times 30 = 900$ ) and divide them by the product of the diameter of A's front roller, and number of spindles ( $5 \times 4 = 20$ ); then  $900 \div 20 = 45$  revolutions of the front roller of A. To find the number of spindles in the spinning frame needed to follow one spindle in any part of the drawing, multiply the diameter of the front roller of the drawing box by the number of its revolutions per minute, and these by the weight of slubbing delivered in the same time (say  $5 \times 45 \times 200$  drams = 45,000) and divide this product by the product of the diameter of the back roller of the spinning frame, its revolutions per minute, and the weight of roving taken in during the same time (say  $1\frac{1}{4} \times 5 \times 8$  drams = 50); then  $45,000 \div 50 = 900$  spindles of spinning for each spindle of the drawing box. This, of course, varies according to the weight of roving and slubbing, and the speed of the rollers, but the method is shown here which applies equally to finding the number of spinning spindles, or the number of spindles in any other operation.

122. **Advantage of Cone Drawing.**—We have seen that in ordinary drawing the bobbin is loose on the spindle, and is dragged round by the slubbing, and that the bobbin increases in speed as it becomes fuller, and also increases in drag or friction, thereby subjecting the slubbing to a considerable strain. The lifter also moves up and down at a uniform rate, irrespective of whether

the bobbin be full or empty, so that for each traverse of the bobbin there is an equal length wrapped round it. In cone drawing, which we must now consider, all these defects are avoided. The bobbin is fixed upon a peg, and is turned round at an increasing speed the fuller it becomes; the drag on the slubbing is entirely removed, and the lifter, or builder as it is called, moves more slowly as each layer is placed on the bobbin, thus making the winding-on more even, and free from all tension. For short loose wool this is a very great advantage, as there are some kinds, such as low carpet wools, which are apt to be strained by the dragging of heavy bobbins. For drawing cotton cone boxes are everywhere used, but we shall note a marked difference in one respect between the finer drawings for cotton and those for worsted.

**123. Principle of Cone Drawing.**—Fig. 34 shows the elevation of a 4-spindle cone drawing box as made by Messrs. Taylor, Wordsworth, & Co., of Leeds, the chief makers of this machinery, and a plan (Fig. 35) of a 12-spindle box, kindly supplied by the same firm. The top part of the former box consists of a screw gill, similar in principle to the open set of drawing, but with four sets of rollers instead of two. The drafting motion, and the gills and fallers are, however, the same, and need no special description. The winding of the slubbing on to the bobbin is also done in the same way, by the flyer and bobbin revolving in the same direction at different speeds, the rate of winding-on being equal to the difference between them, and so far, in its effect, the principle of this box is the same as that of open drawing. But, as we have said, the bobbin is made to revolve at an increasing speed as it becomes fuller, quite independently of the flyer which here never drags it at all. The mechanism which effects this is the “differential motion.” The varied speeds of the bobbin are obtained primarily from two cones, *c c*, one of which is called the top cone, and the other the bottom cone. The former

drives the latter by a belt, s. They are each 5 inches in diameter at the thick end, and 2 inches at the narrow

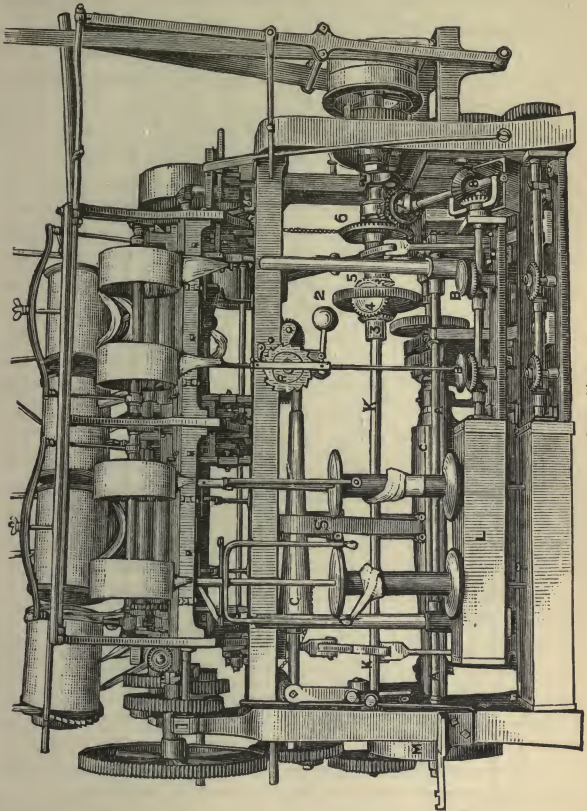

Fig. 34.

one, and are placed parallel to each other, but inversely, the thick part of the one being opposite the narrow part of the other. Therefore if the belt be on the thick part of the top one, which is the driver, we have a 5-inch

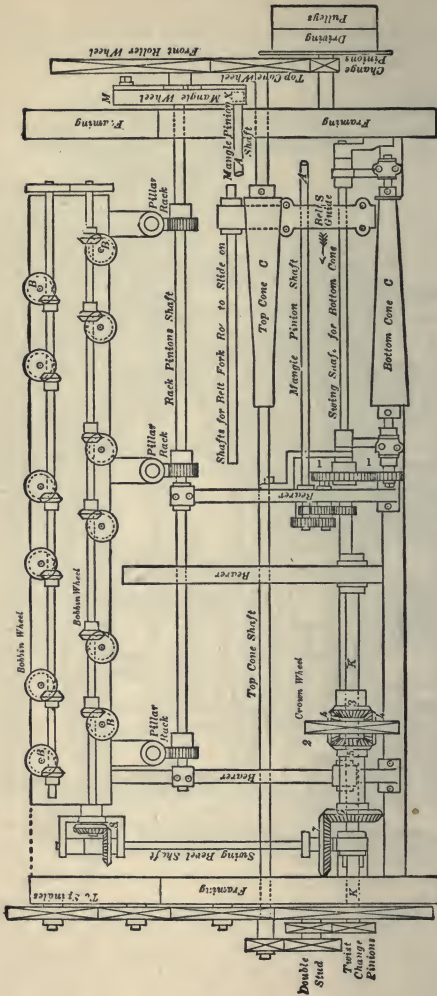

Fig. 35.

diameter driving a 2; but if the belt be at the other end, we have a 2 driving a 5, which gives a very different speed to the bottom cone. As the top cone is in direct connection with the driving gear of the box, its speed never alters; but as the belt guide, *s*, is shifted along, in the direction shown by the arrow (Fig. 35), a certain length for each traverse of the bobbin, it is plain that the speed of the bottom cone must be gradually reduced as the bobbin fills; and as the belt is on the thick end of the top cone when the empty bobbin is placed on the spindle, the cones then revolve at their greatest speed. The bottom cone is in gear, through the wheels marked 1 and 1, with the main wheel of the differential motion called the "crown wheel," or sometimes the "plate wheel," marked 2. The differential motion is also called the "sun and planet motion," because the large crown wheel revolves round two smaller bevelled wheels which also turn inside it. The analogy is not, however, a correct one, for obvious reasons. The crown wheel, as stated, has two small intermediate bevel wheels, 4 4, inserted one on each side of and parallel to its axle. The revolving of the crown wheel, which is regulated by the speed of the bottom cone, carries round these intermediate bevels, and as their centres bisect the radius of the crown wheel, they have twice its power; that is, for one revolution of the crown wheel, they—if held in gear with another bevel of their own size—will turn round twice on their own axles. Now, although the crown wheel is really driven by gearing from the bottom cone, it appears at first sight as if it were driven by the twist shaft  $\kappa \kappa$ , which passes through it, and on which it loosely runs, being itself only a socket wheel. The other wheels, 5 and 6, are also socket wheels and are not fixed to the shaft  $\kappa \kappa$ . The twist shaft, however, has its effect on the crown wheel by means of the small bevel, marked 3, which is the same in size and shape as 4 4 in the crown wheel. It is keyed on to the twist shaft, and geared on to the two inter-

mediate bevels 4 4 inside the crown wheel. It therefore always goes at a fixed speed, viz., that of the shaft. At the other side of the crown wheel is another bevel wheel, marked 5, which is also a socket wheel loose on the shaft, and similar in every way to 4 4, and 3. It is in gear also with the intermediates 4 and 4, and thus a square of four bevel wheels is formed, working round in the crown wheel. Thus the tight driving bevel 3 communicates its power through the intermediates 4 4, to the loose drum bevel 5. This bevel 5 is on the same socket as the large bevel 6, and this communicates through 7 and 8 with the small bevels which are fixed inside the builder or lifter L, and on which is the stand and peg for the bobbin. The driving bevel 3 does not, however, communicate its own speed to the opposite one, 5, because the crown wheel is revolving in the same direction as the former, gives the intermediate bevels twice its own power, and therefore neutralises to a certain degree the effect of the driving bevel. The reason this is called the differential motion is, because the quicker the crown wheel revolves the less power the driving bevel has on the driven, and therefore the slower the bobbins go. The slower the crown wheel goes the more power the driving bevel retains, and therefore the driven bevel goes faster, and the bobbins also go faster. But as the cone is made to go quickest, and thus to drive the crown wheel quickest when the bobbins are empty, it follows that they then revolve slowest; and as they fill, and the cone gradually goes slower and drives the crown wheel slower, the bobbins then increase in speed, so that the flyer may not have so far to travel in wrapping any given length of slubbing on the barrel. The belt is shifted along the cone by means of the wheel R, which — as shown in Fig. 36 — is moved half a tooth for each rise, and half a tooth for each fall of the lifter L. When it moves up, it pushes up the rod F by pressing the washer D<sup>1</sup>, and then loosens the catch E<sup>1</sup>, and lets the wheel R



slip half a tooth. As the lifter sinks again it lowers the rod by the washer,  $D^2$ , and releases the catch,  $E^2$ , so that the wheel  $R$  moves another half tooth, or one whole tooth for each rise and fall of the lifter. The wheel  $R$  has on its stud another wheel, 1, which drives a wheel, 2; this again drives a wheel, 3, while the large wheel, 4, is on the same stud. The wheel 4 has its teeth in the rack; as the wheel  $R$  revolves it draws the rack towards it, and this pulls the belt slides gradually along,

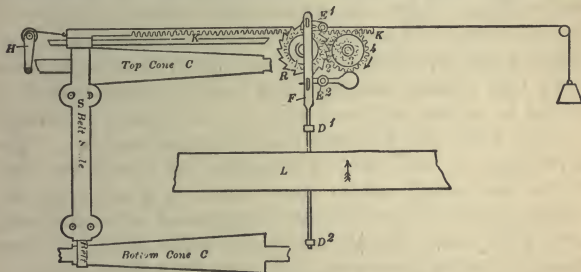

Fig. 36.

thus altering the position of the belt on the cones. Thus, each traverse of the bobbin is the primary cause of the belt sliding on the cones, and thus altering their speed. This mechanism is not shown in Fig. 34 or Fig. 35, but is so important as illustrating how the decrease of speed is obtained for the cones, and through them how all the differential motion is worked, that it is necessary to explain it that the box may be thoroughly understood.

124. **Effect of Cone Drawing.**—The motion of the lifter is regulated by the speed of the lower cone also, as shown in the plan of the 12-spindle box (Fig. 35). By a series of wheels the mangle pinion shaft  $A A$  is worked, which drives the mangle pinion  $x$ , and this drives the mangle wheel. As the cone goes slower, of course all these go slower too; and thus the lifter rises and falls more

slowly just in proportion as the bobbins fill and revolve more quickly. Therefore in a cone box the length of slubbing wound on to the bobbin varies with each traverse of the lifter, which is the reverse of what happens in the open drawing. In the plan of the 12-spindle box it will be seen that the mangle shaft A A is represented broken, but this is because the top cone is really above the lower one and not side by side, as necessarily shown in a plan. Were the box drawn as really seen from above, only one cone could be shown, and the machine could therefore not be explained so well. The spindles are driven always at one speed by wheels direct from the driving shaft of the box, and each spindle is driven by a pair of bevel wheels, but these have no connection with the wheels which drive the bobbins. The advantage of this sort of drawing can easily be seen. There are usually three cone boxes in a set, with two ordinary gill boxes at the beginning, and an open roving box at the end. The slubbing is therefore gilled in every operation up to the roving, and yet there is no drag on the end as it comes from the rollers; it can be wound on to the bobbins in the softest state, and thus there is no need for putting in any more twist than is just needed to make it keep together. The only drawback to this machinery is its initial cost, and the cost of keeping it in repair.

125. **Variation in Speed of Bobbins.**—To get the speed of the bobbins as compared with the spindles, and the increase as the bobbins become fuller, let us suppose in the 4-spindle drawing box the speeds of the twist shaft  $\kappa \kappa$  to be say 101, the spindles 101, and top cone 150. The speed of the bobbins, if the crown wheel were not acting, would then be also 101, for,

$$\frac{101 \times 54 \times 20}{27 \times 40} = 101.$$

The figures 54, 20, 27, 40 refer to the number of teeth in the various connecting wheels. The speed of the crown

wheel is found to be 43 when the cones are running at their quickest, the dimensions being

$$\frac{150 \times 5 \times 42 \times 25}{2 \times 90 \times 100} = 43.$$

As the crown wheel revolves once for the socket's twice, the socket revolves 86 times. The bobbin, without the differential motion, would go at 101, as shown above, therefore  $101 - 86 = 15$ , which is the number of its revolutions. The spindle goes at 101, therefore  $101 - 15 = 86$ , the difference between the speed of the spindle and the empty bobbin. If the cone were at the very slowest speed, viz., with the 2-inch end driving the 5, we should have

$$\frac{150 \times 2 \times 42 \times 25}{5 \times 90 \times 100} = 7$$

revolutions of the crown wheel, and 14 of the socket. But  $101 - 14 = 87$ , which would then be the revolutions of the bobbin, and  $101 - 87 = 14$ , the difference between the spindle and the bobbin. In reality, however, the belt never needs in these boxes to travel to the end, but only a small way along, till the speed of the crown wheel sinks to about 30, the socket to 60, and the bobbin therefore rises to about 40, when the difference between it and the spindle will be about 60. The principle of these ingenious machines will, however, be better seen by considering the use made of them in the cotton trade.

126. **The Bobbin can Lead the Flyer.**—We have thus far assumed that the bobbin always goes slower than the flyer—that is, that the flyer leads, as is always the case with all other drawing where the flyer drags the bobbin round. But it is the beauty of cone drawing that the bobbin, being driven independently of the flyer, may either go slower or faster, as may be preferred. If it goes slower, the slubbing is wound on by the flyer in the usual way; if it goes faster, the bobbin itself does the winding, and wraps the

slubbing on in the reverse direction, so that when it is unwound the bobbin will have to turn the opposite way from that in which "the sun goes." This method is not used in wool drawing, but very largely in cotton, especially in the finer operations of the drawing; and its advantages are that when the drawing box or roving frame starts, the spindles often start first, and, if the flyers are leading the bobbin, they give the slubbing a stretch which may pluck it; but if the bobbins are leading this cannot happen, as then the flyer would merely unwind a very little off them. Also in the former case, if an end breaks, the bobbin continuing to revolve unwinds its slubbing and causes waste. In the latter case this cannot happen, the slubbing being wound the same way the bobbin travels.

**127. Speeds with Flyer Leading Bobbin.**—To understand the principle of this drawing fully in the two cases, the following calculations of relative speeds of bobbins, with (1st) the flyer leading the bobbin, and (2nd) the bobbin leading the flyer, may be given. They are taken from the roving frames in a first-class cotton mill. The frame shaft runs at 365 per minute, the spindles at 1045, the front roller ( $1\frac{1}{8}$  diameter) at 138, delivering 433 inches per minute. The bobbin would revolve 1045 times if the crown or plate wheel were not in operation. The circumference of the bare tube or barrel is 3.73 inches, and the twist per inch 2.4. The circumference of the barrel of the bobbin when full is 11 inches. Then  $3.73 \times 2.4 = 8.95$ , being the twist for one revolution of the empty barrel. Take first the case of the flyer leading the bobbin; then the speed of the spindle,  $1045 \div 8.95 = 116.75$ , or the difference of speed between the spindle and the bare barrel, that of the spindle being the greater. Also,  $1045 - 116.75 = 928.25$  revolutions, or speed of the bare barrels. And

$$\frac{928 \times 365}{1045} = 324,$$

which is the number of the revolutions of the socket on the twist shaft;  $365 - 324 = 41$  being the dif-

ference of *decrease* in speed owing to the action of the crown wheel; and as one revolution of the crown wheel is equal to two of the socket,  $41 \div 2 = 20\frac{1}{2}$  gives the revolutions of the crown wheel. Taking the same figures again, the flyer still leading but with the barrel full, and its circumference 11 inches, we have  $11 \times 2.4 = 26.4$ , the number of turns of twist for one revolution of the full bobbin. The speed of the spindle,  $1045 \div 26.4 = 39.58$  which is the difference in speed between the spindle and full barrel, that of the spindle still being the greater. Then  $1045 - 39.58 = 1005.42$  revolutions, or speed of full barrel. And

$$\frac{1005 \times 365}{1045} = 351,$$

which is the number of the revolutions of the socket on the twist-shaft, and  $365 - 351 = 14$ , being the difference of decrease in speed owing to the action of the crown wheel, which now goes slower,—viz., at 14. Then  $14 \div 2 = 7$  revolutions of the crown wheel. The bobbin, therefore, when empty, goes at 928 revolutions, and when full at 1005, a difference of 77 per minute, and the crown wheel in the former case goes at  $20\frac{1}{2}$ , and in the latter at 7, a difference of  $13\frac{1}{2}$ .

128. **Speeds with Bobbin Leading Flyer.**—When the bobbin leads the flyer we see a different result. Taking all the same figures, we get again 116.75 as the difference in speed between the bare bobbin and the spindle, but in this case it is the bobbin which goes the quickest. Therefore, we add the speed of the spindle to the difference between it and the flyer, and get  $1045 + 116.75 = 1161.75$  as the revolutions of the bare bobbins. Then 1161.75, or, without the fraction,

$$\frac{1162 \times 365}{1045} = 406,$$

the revolutions of the socket, and  $406 - 365 = 41$ , the difference of *increase* in speed of the socket owing to the

action of the crown wheel, and  $20\frac{1}{2}$  the revolutions of the crown wheel in the reverse direction. Similarly we got 39·58, the difference in speed between the full bobbin and the spindle, with the bobbin going quicker. Then  $1045 + 39\cdot58 = 1084\cdot58$  the revolutions of the full bobbin. With the bobbin leading the flyers, therefore, its revolutions when empty are 1161·75, and when full 1084·58, a difference again of 77; but this time the bobbin runs faster when empty than when full, as it has to wind on the slubbing for itself, and therefore run faster before the flyer when its barrel is small. The cones consequently have their operations reversed, going slower when the bobbin is empty. In cotton drawing the change can be made by reversing the wheel on the short upright shaft, and driving it from below. This reverses the motion of the shaft, and also of the crown wheel, causing the bobbin to run faster than the flyer. The cotton drawing is, however, slightly different in its method of gearing from that used in worsted, one of the points of difference being the arrangement of the bevelled wheels marked 6, 7, and 8; but the principle is the same.

129. **French Drawing.**—In all the drawing hitherto described the main principle of the processes has been alike, namely, to draw the slubbing out and wind it on to a bobbin by twisting it round with a flyer, and thus making a number of ropes of wool, which are continually being re-drawn and made over again. The French system of drawing entirely differs from this. The principle adopted is to put no twist whatever into the slubbing or roving, but to keep each fibre as straight as possible until it is spun. To effect this a different class of machinery is used. The balls or tops are taken and mixed in the usual way in the can gill box, in whatever proportions may be necessary. The cans are then taken to the first drawing frame, and placed say two ends together. The back rollers receive them as usual, and the front rollers draw them out, but between the two is a porcupine roller such as we have already mentioned, and

over this the sliver passes, and is drawn through its pins. The porcupine goes a very little quicker than the back rollers, but nothing to speak of. It serves only as a carrier to support the wool between the back and the front rollers, for as there is no twist in the slubbing, if the drawing were entirely open, or with only wooden carriers, it might be plucked and made twitty. The pins of the porcupine pierce it like faller pins, and hold it steady while the front

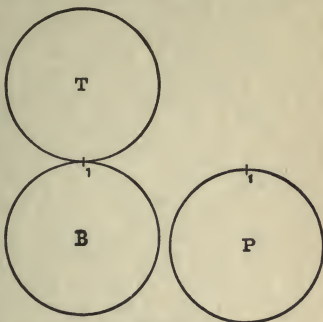

Fig. 37.

rollers are drawing it. The top of the porcupine is raised higher than the nip of the front rollers, for if they were on the same level, the distance between

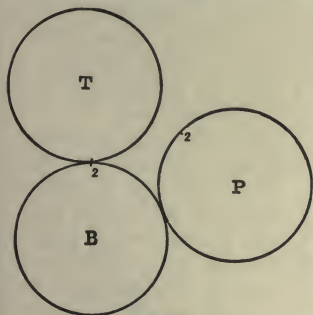

Fig. 38.

the two points would be the sum of the radius of each plus the distances which their surfaces are apart; that is to say, if T be the top roller (Fig. 37), B the bottom one, and P the porcupine, the distance would be from B<sup>1</sup> to P<sup>1</sup>, and the stretch of the wool without any support would be considerable. Besides which the wool could only be supported

just on the top of the porcupine and could not lap round it at all. If, however, the porcupine be raised, the nip of the rollers and the point where the wool leaves the porcupine are brought very much nearer together, and thus

the wool receives much more support both (Fig. 38) by being held to within half the distance from the nip and by having to pass over a much larger amount of the surface of the porcupine. The higher the porcupine is placed the nearer can it approach the nip; but if it be much higher than here shown (Fig. 38), the wool has to rest on too large a portion of its surface. Having been drawn out by the front rollers it passes between two rubbing leathers, similar to those of the condenser in a woollen card, and which will be more fully described when we come to that subject. It is enough here to say that they revolve to meet each other and carry the reduced slubbing through to the other end of their journey. Besides this, they have a motion, rubbing sideways, similar to the motion of the palms of the hands when rubbed flat together. By this motion, though they put no twist into the slubbing, they rub all its fibres together, and instead of a flat open sliver, a rounded pith-like thread is passed out. This is received by a guide wire and wound on to a bobbin lying horizontally, which, travelling at a good speed end-ways, causes the end to keep crossing backwards and forwards. This balling or winding on to bobbins is worked by an oval mangle wheel moving sideways instead of up and down. Two ends are usually run on to every bobbin or ball; so that if two are put up at the back, it is equal to four doublings in the first operation.

**130. Effect of French Drawing.**—Such is the whole principle of French drawing. There are nine operations, each one being in every way similar in its theory to the others, and merely differing in size as the rovings have to be made lighter. Two or three ends are always put together and drawn out, but no twist is ever put in. The rubbers make the pith-like slubbing, which is thereby wound off the bobbin without any trouble. Wool is so much longer proportionately than cotton that with this little rubbing it is all right and firm. There is something seemingly absurd in twisting long or any other kind of wool into a rope and then having to pull it



out again by machinery, just in order that it may be a second time twisted into a thinner rope. The fibres must often be broken in any drafting out combined with twisting, and this will happen just as the slubbing is twisted harder. When we twist the slubbing, the serratures in the fibres of wool tend to fasten into each other, and when they are again drafted, some of the points may be blunted or even broken off. But with French drawing this is not so. The rubbing is just enough to make the fibres hang together, and not enough to felt or squeeze them; indeed, no weight is applied by the rubbers—their function is to rub, and nothing more. This process is repeated nine times, with just as many doublings as may be required, and with suitable draft. In the last process or roving it is the same as the first, except that the bobbins on which the roving is to be wound are filled more slowly and evenly, so as to present on the creel of the mule the appearance of nicely wound bobbins instead of balls crossed from side to side. It is not necessary, therefore, to say more about the construction of these machines. In this country they have just come into use, and so far have been employed only for fine Botany wool, with very small rollers and fine porcupines. The French, however, use them with larger rollers for wool even ten inches long, which they afterwards spin on the mule. In spite of the objection just noted to twisting long fibres and then drawing them out again, it is doubtful whether the French system is so well suited to long wool as that employed here. In a word, the advantage of either system depends on the result it is desired to obtain. If a “foody” bulky yarn is wanted, the French system is best—and for this short wool is most suitable; but if a good, sound, level, thread, with the fibres well straightened and lying close to each other, be aimed at, there seems to be nothing to beat the ordinary method of English drawing, and it has this decided advantage, that a much greater variety of wool can be drawn on one set of boxes than is possible any other

way. To the spinner who lays himself out for all classes of work this is a recommendation that is not likely to be lost sight of, and one which goes far to counterbalance any gain for special sorts which may be obtained by French drawing.

---

## CHAPTER VIII.

### WORSTED SPINNING.

131. **Principle of Spinning.**—There are four methods of spinning worsted, three of which come under the head of throstle frames, viz. : flyer, cap, and ring. The fourth is the mule. We will take these in their order, first pointing out what they have in common. The spinning process is divided into three distinct parts:—(1) The drawing out or drafting ; (2) the twisting ; and (3) the winding on to the bobbin. The last, though necessary in any practical system of spinning, is, in the strictest sense of the term, not a part of it ; because the yarn is spun before it can be wound on to the bobbin, as is clearly seen by the operations of the mule and by the old hand spinning, and the winding-on is only done for convenience. The other two parts are essential, because if twist were put in without drafting, it would merely be twisting a given thickness of roving or anything else ; and without the twist, the roving when drafted has no cohesion, and becomes waste. The part which all four methods have in common is the drafting. In the three first it is literally and exactly the same, for the very same rollers can be used either for flyer, cap, or ring frames. The principle and operation of the rollers is the same in the mule also, but they are set rather differently. When we come to the second part—the twist—the divergence begins ; for though they are alike in so far as they all put twist into the yarn, yet each frame

has its own method of doing it, and also its own method of winding the yarn on to the bobbin.

132. **Flyer Spinning Frame.**—The drawing here given (Fig. 39) of an 8-spindle flyer spinning frame will show the principle of its working very clearly. Roving bobbins

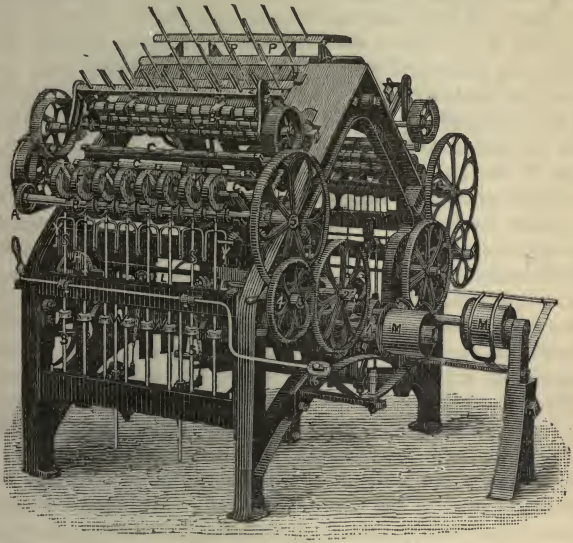

Fig. 39.

are placed on the pegs, P P, one to each spinning spindle. The ends are then passed between the back rollers, which revolve slowly; the lower one of these—the one that regulates the length drawn in—is usually  $1\frac{1}{4}$  inch diameter. The roving then passes between the three sets of carriers, C C C, and reaches the front rollers, F R, by which it is drawn out to any length required, the difference in the speed between the front and back rollers regulating the draft. The bottom front roller, R, is the

one whose diameter affects the draft, the top one being merely a wooden boss covered with leather, and running by friction, every pair being on one axis, which is pressed down by the screws  $\kappa \kappa$ . This is the whole principle of drafting as applied to every operation in the worsted or any other trade where draft is obtained by means of rollers. When the attenuated end comes through the rollers it is twisted once or twice round the wing of the flyer  $\gamma$ , passed through a twizzle at its lower end, and then wound round the bobbin which is on the spindle  $s s$ . The flyer is separate from the spindle, being screwed on to it at the centre of the cross piece. In all drawing boxes the spindle and flyer are joined together. The spindle always revolves at the same speed whether the bobbin be full or empty, and therefore so far as it is concerned, will always put the same twist into the yarn. The bobbin travels up and down on a lifter plate,  $L L$ , which moves up and down the spindle, being worked by the revolutions of a heart-shaped piece of iron,  $H$ , and a series of chains and pulleys. This heart varies in construction according to the shape of bobbin required. Three sorts of bobbins are used—the ordinary bobbin with a head at each end, which fills evenly from one end to the other and back again; the tube (made of paper) which requires a double motion to fill it, namely the ordinary one up and down, working about half its length, and a constantly lowering one which causes the tube ultimately to be filled over its whole length, but to be much fuller at the centre than at the ends; and, thirdly, the spool, which has a flange only at its lower end, and which requires a triple motion; a very short one at first filling the lower end, during which time the bobbin only moves a little way up and down, and then a longer “picking,” as it is called, up and down, with the constantly lowering motion the same as for the tube; so that a full spool gradually tapers from the bottom towards the top. Into a description of how these hearts are to be set, and their shape, it is not necessary to enter, our

object being to deal with the principles of spinning. The spindles themselves are driven by cotton bands from a tin cylinder, which is fastened to the main shaft that drives the frame, and, therefore, revolves as quickly as the driving pulleys. The bands run round the wharls, w w, on the spindles, and as the diameter of the former is 9 inches and the latter 1 inch, there is, of course, a great increase of speed.

133. **Flyer Spinning; Twisting and Winding the Yarn.**—We must now see how the flyer operates in twisting and winding the yarn, and we will suppose that there is on the spindle an ordinary spinning bobbin, 3 inches long inside the ends and 2 inches across. The diameter of the front roller is 4 inches, and the circumference, therefore, 12·5. It is revolving 20 times a minute, and therefore delivering 250 inches of yarn in that time. The spindle is revolving 3,000 times a minute, and there should therefore be  $3,000 \div 250$ , or 12 turns per inch in the yarn if nothing were lost by the slipping of the band. The spindle, or rather the flyer, puts twist into the yarn in the following way: It revolves “the way the sun goes,” the yarn is hooked into the flyer-eye, or twizzle, at its lower extremity, and as it revolves it carries the yarn round with it, thus twisting it, and putting in one turn for each revolution. If the bobbin and flyer went at the same speed, there could be no winding on, only twisting; but as the bobbin is loose on the spindle, its tendency is to stand still, and it is merely dragged round by the end of the yarn, which is passed through the flyer eye. This is the case with all open drawing as distinct from cone drawing, as we have previously seen; and it will be found that in the former and in flyer spinning the speed of the bobbin varies according to the circumference of the barrel, empty or full. If the bobbin stood quite still while the flyer went once round it (which could only be done if the delivery of the rollers were quick enough), there would be just one turn put into the yarn in the length equal to the circumference of

the bobbin; but as the bobbin travels round, being dragged nearly as fast as the flyer, any number of turns can be put in before the winding takes place. The rate of winding is in proportion to the difference in speed between the bobbin and the flyer, and this difference varies in proportion to the circumference of the full or empty barrel. If the diameter of the flyer be  $2\frac{3}{4}$  inches, with circumference of 8.63, and that of the

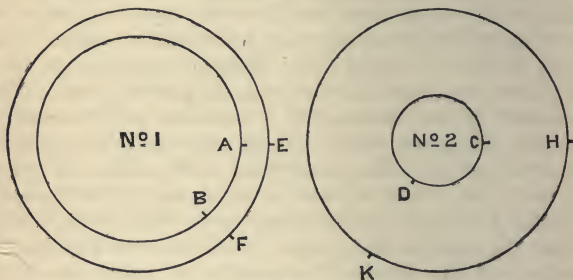

Fig. 40.

empty bobbin barrel  $\frac{7}{8}$ -inches with circumference 2.75, and of the full bobbin 2 inches, and 6.28, then it is clear, as shown in Fig. 40, that the flyer must travel farther from H to K to wrap an inch of yarn on the empty barrel than from E to F to wrap the same round a full one. Now, as here shown, the distance which the flyer travels round the bobbin varies exactly as the circumference of the barrel. In No. 1 the circumference of the full bobbin is 6.28; therefore, as  $6.28 : 8.63 :: 1 : 1.37$ , which is the distance the flyer travels to wind on 1 inch of yarn. In No. 2 the circumferences are, as  $2.75 : 8.63 :: 1 : 3.13$ , which shows the increase in the distance the flyer must go to wind 1 inch of yarn on to an empty bobbin. The diagram (Fig. 40) makes it appear as if the bobbins are standing still, but of course this is not the case. They revolve, and the yarn is not

laid on a whole inch at a time, but is constantly being wound as the bobbin drags behind. As, however, the same amount of yarn is wound on to the bobbin at each moment or for each traverse up or down of its lifter, it is clear that the fuller the bobbin the quicker it must run, and this difference in speed is proportionate to the circumference of the bobbin barrel. For if the bobbin went at the same speed when full as when empty, the flyer would break the thread in its efforts to get round. Therefore, the *difference* in the speed of the bobbin at these given circumferences is, as  $2.75 : 6.28 :: 1.37 : 3.13$ . This is also inversely proportionate to the distance the flyer has to travel to wind on one inch. The actual speeds of the bobbin depend, of course, on the speed of the frame. The amount of twist affects the rapidity with which the yarn can be wound on. The increase in speed of the bobbin when full has two awkward results. The bobbin is, in the first place, heavier when full than when empty, and this in itself would increase the friction as it is dragged round. In the second place, even if it were not heavier, the increased speed at which it must revolve increases the friction and also the drag. These two factors combined have this result, that when the bobbin is empty, or nearly so, it does not drag enough, and the yarn tends to "snarl" and curl, and cannot be drawn out straight; and when the bobbin is full, it drags too hard, and the yarn is pulled too tight and often snaps. Hence the spin is always worse in a fine count when the bobbin is full, because the thread being small it is pulled in two and broken; and it is worse in a thick count when the bobbin is empty, because then the thread snarls. It is one of the nicest points an overlooker has to decide, how hard he shall drag his bobbins; and as he judges so he will regulate his washers. The washers are small circular pieces of cloth or leather with a hole in the centre, which are placed on the spindle between the bottom of the bobbin and the lifter rail. Leather washers drag harder than cloth, and large ones harder

than small ones. The drag on the yarn can also be lessened by twisting the thread round the wing of the flyer, and increased by untwisting it and merely hooking it in the flyer eye. The reason of this appears to be that when the yarn is only hooked in the flyer eye the bobbin drags it all the way from the nip of the rollers, there being nothing to break the force of the pull. But when it is twisted say three times round the flyer wing, the drag of the bobbin is almost confined to the very short distance between the flyer eye and itself, the friction or the wrapping of the yarn round the steel flyer having the effect of preventing the tension from getting above that point, and leaving the portion of yarn between the top of the spindle and the rollers quite unstrained. By attending to this, and reducing the other drag of the bobbin by light washers, the amount of drag may be reduced to a minimum. The weakest point of the flyer frame is, however, the irregularity of the drag. As we shall soon see, the cap and ring frames are free from this evil; and the flyer will never be perfect until some cheap and effective method of dragging has been invented which will never vary as the size of the bobbin alters. Irregularity in twist is often caused by the slipping of the spindle-band. As a 9-inch cylinder drives a 1-inch wharfl, which is of smooth polished iron, there is not a great deal of surface which can make the band grip the wharfl, and if the band is a little slack, it will slip considerably. It is impossible to tell how much a band slips in this way except by counting the turns in the yarn—not an easy thing to do in single yarn, though quite easy in twofold. All that the overlooker can do is to see that slack bands are taken off, and that when new ones are put on they are properly tied. There is a right way and a wrong one of tying spinning bands. They must be so tied that all the knot lies on the outside of the band, so that when it passes over the wharfl the jerk caused by a knotted lump suddenly coming and stretching the band is avoided. To remove the danger of the



knots altogether, bands are now made just the required length with a loop at each end, and the loops are fastened together with a little wire hook, and thus they run perfectly smooth. Opinions vary as to the duration and success of these loop-bands, but there can be no doubt the principle of them is a great improvement on the old system of knots.

134. **Calculations for Twist and Speed.**—Having said so much about the twist, let us see how to tell what amount there is in any yarn, and how quickly the spindles revolve. To find the latter, take the dimensions of everything that affects it, and classify the “drivers” and “drivens” into two sets, according as an increase in size gives an increase or a decrease in speed. It will be found that there are five factors in the result. The speed of the driving shaft, the diameter of the drum on it, the diameter of the pulleys on the spinning frame end marked *M* in Fig. 39, and the diameter of the cylinder and wharl. The first, second, and fourth of these, if increased, give more speed; therefore they are “drivers.” The third and fifth, if increased, give less speed, and are therefore “drivens.” Let the speed of the shaft be 138 revolutions per minute; the drum be 40-in. in diameter; the driving pulley 20 in., and the cylinder and wharl 9 and 1. Then we get

$$\frac{138 \times 40 \times 9}{20 \times 1} = 2,484,$$

the speed of the spindle if nothing is lost by slipping. To save reckoning this up every time a gauge point can be taken, which is obtained by merely leaving out the varying factor, viz., the size of the pulley, and we get

$$\frac{138 \times 40 \times 9}{1} = 49,680,$$

the fixed or gauge point for the frame. It is well to have a large pulley on the frame end to prevent the belt from slipping. To obtain the twist of the frame other dimensions must be taken, but the same principle of

“drivers” and “drivens” employed. In Fig. 39 the frame is driven entirely with wheels, the advantage of which is that there can be no slipping of the twine wheel belt; but its drawback is a great increase of noise. The other way is to make the wheels marked 1 and 3, which are 24 and 60 respectively, into pulleys, usually 6 and 15 inches diameter, and drive the latter from the former. The wheel 2 is an intermediate single stud wheel, and counts for nothing. The wheel marked 4 is behind that marked 3; it is geared into 5, and is the change wheel. Suppose it to be a 48. No. 5 is a 215, and is fixed to the front roller. The front roller is 4 in. diameter, or  $12\frac{1}{2}$  in. circumference. The cylinder and wharl are 9 in. and 1 in. as before. All these wheels affect the speed of the front roller, and the quicker it goes the more yarn it will deliver, and the less twist there will be. By increasing the “drivers,” therefore, we get less twist in the the yarn but a greater length of it, because more speed. By increasing the “drivens” we get less speed, and therefore more twist. The cylinder and wharl are the reverse. They do not affect the roller, only the twist; if the cylinder be increased, the spindle will be driven faster, and more twist be given. If the wharl be increased, the reverse will be the case. Grouping these together and multiplying as usual, we get

$$\frac{9 \times 60 \times 215}{1 \times 24 \times 48 \times 12\frac{1}{2}} = 8.$$

If instead of driving the frame by gearing, the more usual form of a belt be substituted, with a 6-in. pulley driving a 15 instead of a 24 wheel driving a 60, the result is just the same. To save so much reckoning a gauge point can be used, which is obtained by leaving out the change wheel (the 48), when the result is 387. From this gauge point the wheel required for any given twist can be found by dividing 387 by the twist; and similarly the twist from any given wheel can be found by dividing 387 by the wheel.

135. **Calculations for Draft.**—The draft of the frame can be obtained by similarly taking the wheels which affect it; but in doing so it must be borne in mind that the front roller drives the back, not the back roller the front, and that when the draft is altered it is done by changing the speed of the back roller. A glance at the frame will show this. The driving power comes from the pulley M, through all the twine wheels, to the front roller, and through it to the draft change wheel A and three other wheels, and then to the back roller, where it stops. The front roller (4-in. diameter) is, therefore, the first “driver,” and the back roller (1¼-in.) the last “driven.” The four wheels between them are the change wheel A, which we will take as a 49; the stud wheel is 100, the plate wheel 84, and the back roller wheel 155. The first and third of these, if increased, will make the back roller go quicker, and are “drivers;” the second and fourth will do the reverse, and are “drivens.” But the faster the back roller goes the less draft there will be; therefore we have

$$\frac{4 \times 100 \times 155}{1\frac{1}{4} \times 49 \times 84} = 12, \text{ the draft.}$$

Thus, by increasing the change wheel, the back rollers go faster, and less draft is given. The gauge point can be obtained here, too, by leaving out the change wheel 49, and will be found to be 590. By dividing any wheel into this, the draft of it is given; or by dividing any draft into it, the required wheel is given.

136. **General Formulæ for Spinning.**—The above calculation and gauge point are only for the wheels of the frame. It will be well here, while on the subject, to give the general rules for finding the draft required, and in doing so we must refer to the calculations given in the chapter on drawing for finding the weight of rovings. There are four things, any three of which must be known to help to find the fourth—viz., draft of frame, called D; counts of yarn, C; length of roving, L; and weight of that

length, w. The complete formulæ are  $560 \times c \times w = 256 \times D \times L$ , and of these six any one can be got by multiplying the three together and dividing their product by the remaining two. To simplify this, instead of taking 560 and 256 (the number of yards in a hank and of drams in a pound respectively) take 35 and 16, which are the sixteenth part of each. For example, let c be 30, L 40 yards, and w 7·3; it is required to find D.

$$\frac{35 \times 30 \times 7\cdot3}{16 \times 40} = 12, \text{ the draft.}$$

These formulæ do for any length, counts, etc., but if a gauge point be used, it must be for some given length, and in that case the equation is simplified by leaving out the 560 (or 35), the 256 (or 16), and the length, and we have  $c \times w = D \times \text{gauge point}$ . For 40 yards the gauge point was found to be 18·3; therefore, as above,

$$\frac{30 \times 7\cdot3}{18\cdot3} = 12, \text{ the draft.}$$

As will be seen by comparing this calculation with the one immediately above, the gauge point for 40 yards, *i.e.*, 18·3, is merely 560 divided into  $256 \times 40$ ; or, which is the same thing, 35 divided into  $16 \times 40$ ; that is,

$$\frac{256 \times L}{560} = \text{Gauge point for any length.}$$

137. **Cap Frame.**—The flyer spinning-frame is chiefly used for worsted yarns of thick and medium counts, but for fine Botany yarns the cap frame is always employed. For yarns intended for twisting such as 32's and 40's, and for even heavier counts where roughness of fibre does not much matter, the cap frame is also very useful, as it can be run at a much greater speed than the flyer. The drawing here given of an 8-spindle cap frame as made by Messrs. Prince Smith and Son, of Keighley, shows the difference between it and the flyer (Fig. 41). It is merely a sample frame, for they can be made

any length ; 180 spindles, and even more, being now common. The upper part of the frame, its rollers, carriers,

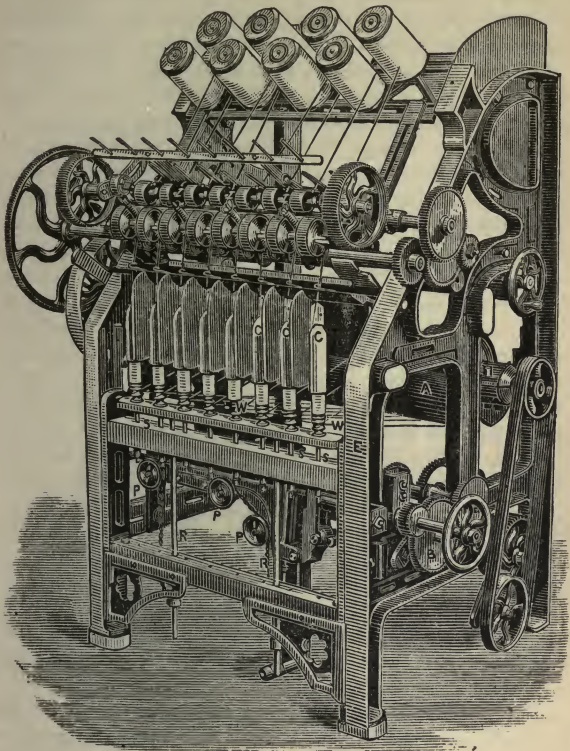

Fig. 41.

twine and draft wheels, are on precisely the same principle as those shown on the flyer frame, the draft wheels here being shown on the side which in Fig. 39 was occupied by the twine wheels, and the same calcu-

lations just given are applicable to this frame also. The difference, therefore, is in the spindles and caps. As will be seen, the spindles *s s* do not reach the bottom rail of the frame, as in the case of the flyer frame. Moreover, they do not revolve. They are stationary, and on them is placed a cap, *c c*, which is a steel cup, the shape of the bobbin, but slightly larger so as to admit it even when full. These caps can be taken off and on, and must be removed to change the bobbin, but while the frame is running they remain on. The rotatory portion is a small tube or shell, which fits inside the bobbin, and to which is attached the wharl, *w w*. This is placed on the spindle, so that we have—firstly, the spindle standing still; secondly, the shell or tube, with the wharl on it rotating round the spindle and resting on the lifter plate *E*; thirdly, the bobbin revolving with the shell, but fixed on to the top of the wharl by a little peg which stands up from the latter and fits into a groove cut in the bottom of the bobbin; and, fourthly, the cap resting on the top of the spindle and therefore remaining stationary. Instead, therefore, of the flyer revolving round the bobbin, and putting in the twist, we have the bobbin revolving round the spindle and inside the cap, and putting twist into the yarn for itself. The cap serves a double purpose, the bottom rim guides the yarn where to wrap round the bobbin, and the rest of it forms a smooth surface round which the yarn can revolve without much friction, and without rubbing against the upper part of the bobbin while filling the lower part. As we shall see presently, the action of a cap frame is very similar to that of a worsted mule; in both cases the bobbin puts in the twist; the cap in the one case and the faller and counter-faller wires in the other, clearing the yarn from the top of the bobbins prior to winding on. In the cap frame, however, the winding on is continuous; in the mule it is intermittent. The shell and bobbin revolve in the same direction as a flyer spindle, viz., “as the sun goes.” If twelve turns are to be put into the yarn per inch, the

bobbin must revolve twelve times while the rollers deliver one inch, and must also take up an inch of the yarn previously delivered, for here it is the bobbin that both twists the yarn and winds it on to itself by its own speed ; and the greater the speed the more tightly will the yarn be wound. Therefore when the bobbins are too soft, the only way of making them harder is to make them run faster in proportion to the speed at which the yarn is being delivered ; and to do this involves putting more twist into the yarn, which is the most serious drawback to this method of spinning. Owing to this method of winding, the yarn is wrapped round the bobbin in the opposite direction from that of a flyer frame because as it were, the bobbin drives the yarn before it, and then takes it up in the same way that it revolves.

138. **Drawbacks and Advantages of Caps.**—It will be seen that there is nothing to protect the yarn while it is being twisted. It revolves at a great speed outside the cap, and its friction against the air must be very great. To prevent the ends from flying into each other, tin shields are fastened between each bobbin, and against these the yarn must sometimes beat. The consequence of this is that the yarn becomes “wild,” and loose hairs stand out from it, so that it has, when wound on to the bobbin, a beard or fringe all round. With very fine Botany this fringe is not serious, as the fine hairs do not stand out ; but with lower yarns it is so large as to prove a serious objection, and make it worth less. The greater cheapness of spinning on the cap as compared to the flyer counterbalances this, for the speed at which the former can be run is about double that of the latter. The reason of this is that instead of the long flyer spindle which would become unsteady at a much greater velocity than 3,000 revolutions per minute, there is only the little shell and wharl to drive, which are supported inside by the stationary spindle, and can therefore be driven at any speed necessary. This is a great advantage for fine counts ; for if they were to be spun on the slow-running

flyer, the weight per day turned off would be sadly diminished.

139. **Movable Cylinders for Cap Frames.**—The fact that the wharl moves up and down on the lifter has until quite recently been a serious drawback, by making spinning bands irregular in their tension. The wheels regulating the lifter (Fig. 41) are at B, and the lifter is made to rise and fall by the action of the rods R R, which are worked by pulleys and chains, P P; when, therefore, the lifter E is at the top, the length of the spinning band is slightly different to what it is when the lifter is at the bottom, and thus its tension and driving power are constantly altering. When the bobbins are short, this is not very serious; but as every one now endeavours to spin on as large a bobbin as possible, the varying tension is found to be a great drawback, for of course the greater the distance which the lifter travels the greater will be the variation in the band. Mr. Prince Smith, Junr., and Mr. Smith Ambler, of Keighley, have taken out a

patent which overcomes the difficulty by making the cylinder travel up and down with the lifter, and thus keep the bands as uniform as in the flyer frame. The lifter motion is greatly strengthened, and heavy balance weights are attached to make the cylinder rise and fall with ease; but the principle of the lifter is not altered at all. It is worked on each side as before, with one large heart and with the chains and pulleys. The great difficulty has been that the driving pulleys of the frame have always been on the cylinder end, and clearly, they could not be made to rise and fall if thereby the

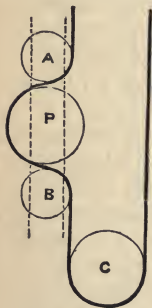

Fig. 42.

driving belt would be made slacker or tighter. By this invention, however, the driving belt is first taken round a fixed pulley, C, round a guide pulley, B, the driving pulley, P, and finally round another guide pulley, A; or the reverse



way, according as the belt may run (Fig. 42). The driving pulley P and the guide pulleys A and B are fixed by their axes on to a sliding-frame which moves up and

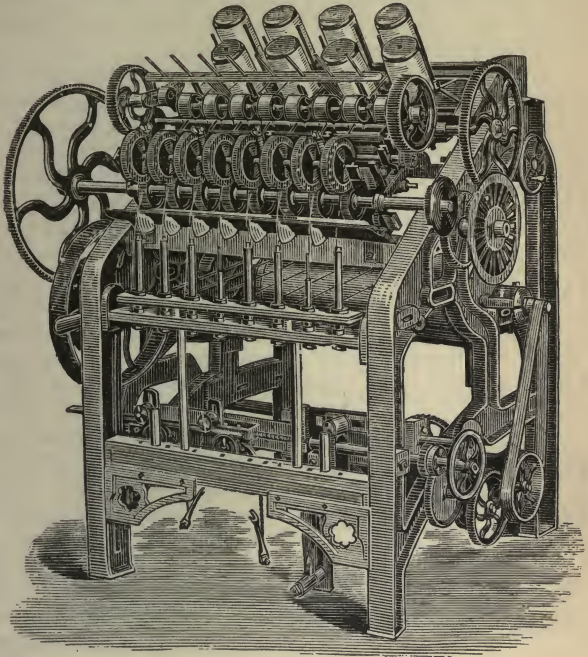

Fig. 43.

down with the lifter, and thus, whether P, A, and B are at the top or at the bottom, the driving belt is always kept at the same tension by the lowest pulley c. This simple but ingenious contrivance will enable much larger bobbins to be used than heretofore on cap frames. Indeed, there seems no limit now to the size of cap bobbins, because as they are fixed on to the shell

and revolve with it, the drag is always exactly the same whether they be large or small, full or empty; and therefore it has only been a question of the varying tension of the bands that has kept down their length. With flyer frames, the increased drag with large heavy bobbins is the main obstacle to increase in size.

140. **Ring Spinning.**—The latest development of throstle spinning is the ring frame, which is now superseding the flyer frame entirely in the cotton trade, and has been also used with success both for spinning and twisting worsted. The drawing here given (Fig. 43) of an 8-spindle sample ring frame, as made by Messrs. Prince Smith & Son, will show in what it differs from the flyer and cap. The spindles are short like those of the cap frame, but unlike them in operation, because they revolve, the wharfl being fastened to the spindle. Also fastened to it, but rather above, is a little plate with a peg in it on which the bobbin rests. By means of the peg the bobbin is fixed to the spindle and revolves with it, thus

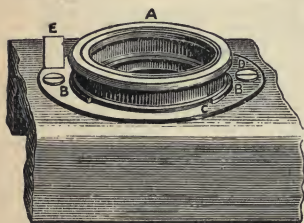

Fig. 44.

putting in its own twist. The bobbin in the ordinary ring frame does not move up and down on a lifter. The ring rail is the lifter, and as it moves up and down with the usual motions previously described, it fills the bobbin. The ring A (Fig. 44) is made of steel and turned perfectly true,

any flaw being a fatal defect in it. It is fixed on to a holder, C, by two rims, B B, and this holder is screwed on to the ring rail. The top of the ring has a flange, and on this runs the traveller, which is a small semi-circle of finely-tempered steel, with the ends somewhat closed together so that it requires pressure to squeeze it over the flange of the ring. The upright block, E, is the traveller clearer, which knocks off any fibres that may adhere to

the traveller. These rings are, according to the pattern made by T. Coulthard & Co., of Preston—the makers of the Booth-Sawyer spindle—perhaps the best and most extensively used of any. The yarn is passed under the traveller, and as the spindle revolves in the same direction as in the flyer and cap frames, the yarn is, of course, twisted round with great velocity and the twist put in. The bobbin and spindle, of course, do not vary in speed ; in this they differ from the flyer frame where the bobbin increases in speed as it gets fuller, and where the flyer always goes at the same speed. Here it is the traveller that alters slightly. Its duty is to wind the yarn on to the bobbin and to affect the drag, for the larger it is the more power the yarn needs to exert to pull it round, and therefore the greater the drag on the yarn, and the tighter it is wound on to the bobbin. By reducing the size of the traveller the drag can be made exceedingly slight, so that this frame is suited for very fine counts. In this it also resembles the mule, because the spindle puts in the twist, and as the bobbin revolves its action is constantly to be unwinding the yarn, while the drag of the traveller acts so as to wind it on again, and as this latter is the greater power of the two, the bobbin is filled.

141. **Improved Lifter Motion.**—The drag or tension of the yarn varies a good deal according as the ring rail is at the top or the bottom ; for if the bobbin be, say, four inches long, then when the rail is at the bottom there is a stretch of four inches more yarn to pull at than when it is at the top. To obviate this Mr. George Salt has patented a very simple contrivance, as shown in three diagrams (Fig. 45, I, II, III). He merely fixes the ring rail, H, by pillars, K K, or other fastenings to the frame, and places on the spindle a tube similar to that used in cap spinning. The bobbin fits on to the tube, and the tube rests on the lifter rail, F F, and moves up and down, with the whar, C C, also moving up and down just as in the cap frame, and thus the bobbin is filled. In fact he merely substi-

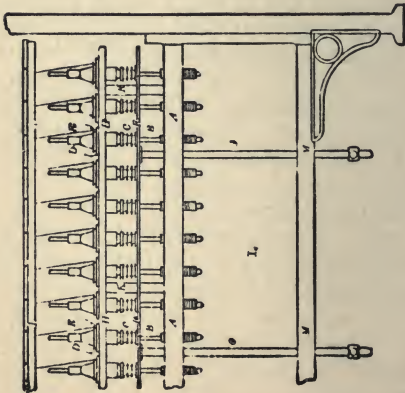
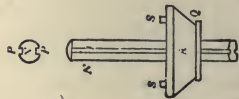
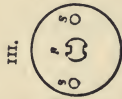
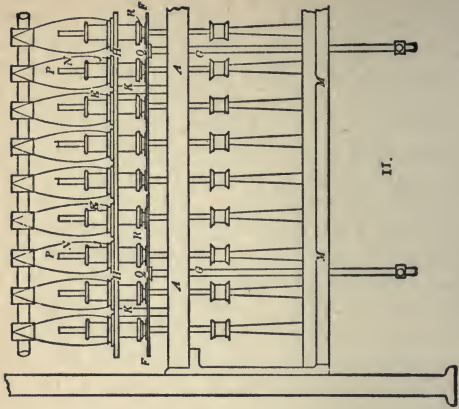

Fig. 45.

tutes a ring and traveller for the cap. Where, however, the spindles are long like flyer spindles he secures the ring rail as before mentioned, but in place of using short cap tubes to run on them, he cuts two longitudinal grooves or key ways, *p*, in the spindles the whole length of the traverse. On each spindle he places a washer, *q*, and collar, *r*, which rest on the lifter plate; each collar has two keys fastened to it, which slide up and down in the grooves of the spindle, and thus ensure that the collar and the bobbin which is fixed on to it by pins, *s s*, revolve at just the same speed as the spindle, and yet move free with the lifter plate.

142. **Important Points in Ring Spinning.**—It is one of the advantages of ring spinning, that an ordinary flyer frame can be converted into a ring without altering the spindles. All that is needed is to take off the flyers and the lifter rail, screw on to the spindles at the proper height collars with a peg standing up on which to fix the bobbin, and then to put on the ring rail to work up and down. The change is so inexpensive that it gives every one a good opportunity for trying ring spinning, and if it is found to succeed, the short spindles, which are better because they are steadier and can be run faster, can then be substituted. The most important points to attend to in ring spinning are to have the spindles perfectly true and upright; to have the rings also true and set exactly concentric with the spindles, *i.e.*, to have the centre of the spindle exactly in the centre of the ring; to have the travellers in good order and not worn sharp or uneven; and, lastly, to see that no waste is allowed to accumulate anywhere, and that everything is kept well oiled. The thread guides must also be set exactly over the top of the spindles so that the yarn when revolving shows a perfect cone. This is an important point in all spinning, for if the guide wire be on one side, the yarn will beat against the flyer or the spindle as the case may be, and will be apt to get broken and ruffled. In so delicate an operation as spinning, the greatest attention must be given to the

numerous small points, and according as they are cared for or neglected, so, other things being equal, will the spin be good or bad. There is probably a great future for ring spinning, and even for ring drawing in worsted, for so far as it has been tried it has answered all that can be expected from it. Its two strong points are that it can be run at a great speed and yet does not make the yarn so wild as does the cap frame.

143. **Fox's Ring and Cap Frame.** — A combination of the ring and cap frame has been invented and patented by Mr. Fox, of the firm of Messrs. W. Fison & Co., of Burnley, which is specially suited for lustre wool, and for which it is claimed that it makes better yarn than the flyer frame at a much less cost. Fig. 46 shows it in section and in elevation. We quote the following description of it from the *Textile Manufacturer*, which explains its action briefly and well; but with this additional remark, that the ring rail is fixed and stationary, the filling or building of the bobbin being done on the ordinary cap principle of the bobbin moving up and down:—

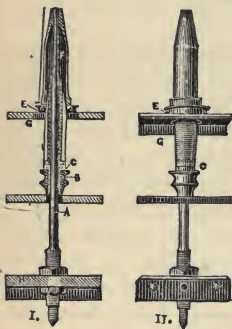

Fig. 46.

“By means of the invention we now illustrate the rate of spinning can be greatly increased over that of the flyer, in fact about double, without impairing the smoothness or brightness of the yarn, but on the contrary with a marked improvement in both. This remarkable result is obtained in a striking and simple way, by the combination, in fact, of two other systems of spinning, viz., of the ring and traveller with the cap. The ring and traveller are applied, of course, in a particular way. Fig. 46, I is a section of the component parts of the spindle; Fig. 46, II is an elevation. In

Fig. I, A is the spindle which remains stationary, being fixed by nuts to the lower rail, H. The wharve, B, together with sliding tube, C, runs loosely on the spindle and carries the bobbin. Upon the top of the spindle is the cap, F, covering the bobbin. So far we have the ordinary cap spindle, except that the bottom edge of the cap is shown thickened. Upon the upper rail, G, is carried the ring, E, with its traveller, and the principal point upon which the utility of the combination depends is the positions of the ring with respect to the lower lip of the cap. They should be so disposed that the yarn in its course from the traveller to the bobbin just passes underneath, and in gentle contact with, the widened edge of the cap. By means of the nuts this adjustment is readily made to the required nicety. The action of the whole is explained in a few words. The yarn is actually spun on the ring system, but the projecting fibres, which would make it stary and lack lustre, in passing beneath the cap get laid along the yarn and twisted into the body of it. We may say it is practicable to use a heavier traveller than usual. This effect of the application of the cap is easily demonstrated. By raising it slightly, so as to remove contact with the thread, thus practically converting the frame into an ordinary ring frame, it will be found at once that the traveller is too heavy, and probably the end would break. A lighter traveller may be substituted, and the spinning proceeded with, but the result will be that the yarn is rougher than that produced with the flyer. If now the cap edge is brought into slight contact with the thread, an improvement in smoothness will be noticed, and a heavier traveller will now be required to obtain the proper drag which, in a somewhat curious manner, is lessened by the application of the cap. With proper adjustment the yarn produced is smooth, soft, and lustrous."

The speed at which this spindle can be run for ordinary lustre is 4,500 per minute, while 2,500 is the outside for a lustre yarn on a flyer frame. For mohair

it can be run up to 5,000, and its production is proportionately increased.

144. **Mitchell's Caps for Spinning Bobbins.**—Another invention of great use to mohair spinners is that of Mr. Tom Mitchell, of Messrs. Mitchell Bros., Bradford, for preventing the formation of a beard on spinning bobbins (Fig. 47.) With mohair and other wools that contain strong hairs,

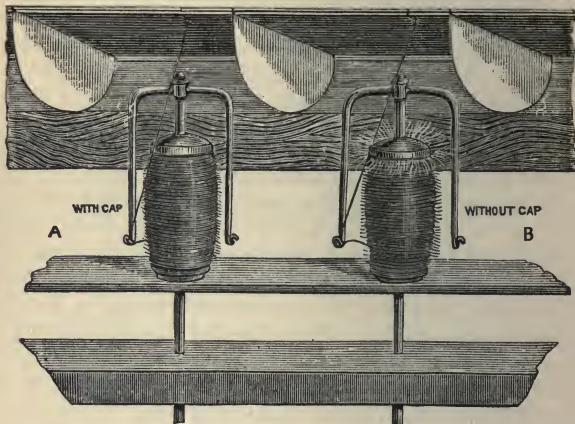

Fig. 47.

and especially kemps, there is always at the top of the bobbin a beard formed by the centrifugal force which throws the loose fibres outwards, and when the lifter is being lowered they will also be thrown upwards. During the traverse of the bobbin these hairs are bound in by the layer on the top of them, but at the top of the bobbin they fly outwards and upwards, so that there is nothing to bind them down. Consequently a wild beard is formed, which catches and often breaks the thread as it passes, and even gets entangled round the flyer wing. But by simply placing a metal cap over the top of the bobbin, with its edge bent down to just below the rim of the



bobbin, each layer of beard, instead of standing up, is bent downwards, and so gets folded in with the succeeding layer of yarn. The result is that the yarn is smoother; the long hairs are better twisted in; the flyer, instead of being very wide, as shown in B, to avoid the beard catching it, is made narrower, and fits close to the bobbin, thereby improving the spin, for nothing tends more to make a yarn spin badly than to have the flyer too large for the bobbin. In all these ways the yarn is improved, and a saving is obtained in the amount of waste made.

**145. Stop Motions for Spinning Frames.**—The greatest desire of all inventors in the worsted trade has been to make a spinning frame which can be doffed all at once mechanically, without each flyer having to be unscrewed, and also to make a frame which will cause no waste or lap when an end breaks. The former of these is far the more difficult; and though a very ingenious attempt was made to achieve the result a few years ago, and with considerable success, still other drawbacks were developed, and therefore the frame was not actually the saving which it proposed to be, and so it was not adopted by the trade. With waste-preventing machines much more progress has been made. The principle which any such frame must adopt is to stop the delivery of roving by the back rollers as soon as an end breaks, for even were it possible it would do no good to stop the front rollers. It is also impossible to stop the motion of the bottom back rollers, because to ensure regularity of draft they must be all fastened together. Therefore only three ways seem to be left: either the top back roller must be lifted up, and a catch operate to hold the roving from being dragged down by the front rollers, or else the delivery of roving must be stopped either by stopping the roving bobbin itself, or by stopping the top back roller without lifting it. The first of these would be the best, but is the most difficult because it would need two motions, one for raising the top back

roller, and the other for stopping the roving. But it is best, because the roving would not then be rubbed between the back rollers. To the second way the objection is that if the roving bobbin be stopped and the back rollers continue to revolve, they tend to grind the roving between them; while if the third way be tried, and the top back roller stopped while the bottom one revolves, the latter will tend to grind the roving against the former. Patents for these two stop motions have been taken out by Mr. Tom Mitchell, above referred to, and by Messrs. Crossley & Sutcliffe respectively; and it must be admitted that both seem to work well, and certainly prevent waste. Space prevents us from describing these and others of a similar kind at length; but we quote from the *Textile Manufacturer* again a brief notice of Mr. Mitchell's, which is the simpler of the two:—

In Fig. 48 “the old parts of a worsted frame are shown dotted, and the new in full lines. The top board, it will be noticed, is dispensed with; the delf or pottery eyes for the yarn are fixed instead, in levers, c, balanced in brackets attached to the front rail, as shown. The front pressing rollers, A A, are as usual; but the top carriers, J J J, instead of working in pairs, as formerly, are separated, so as to work independently. The bottom feed roller, B, is *smooth*; it may be made of the old feed-roller shaft, with the flutings turned away. The top feed-roller, B<sup>1</sup>, is also smooth, and to dispense with the springs commonly employed it is made solid, and gives the pressure on the roving by its weight alone. The substitution for the old roller weighted with a spring, of a solid one acting by its own gravity, is regarded as an improvement, because with springs the pressure put on the roving is scarcely ever uniform throughout the frame. The bobbin, κ, instead of turning in a peg, is mounted, in the arrangement shown in enlarged section. The cast-iron washer, F, has two pegs, G G, which enter holes made in the bobbin bottom; this washer is connected by bevel

gear with the spindle, E, made of stout iron wire, mounted as shown, and carrying at its lower end a toothed wheel, D. Following out the action of this mo-

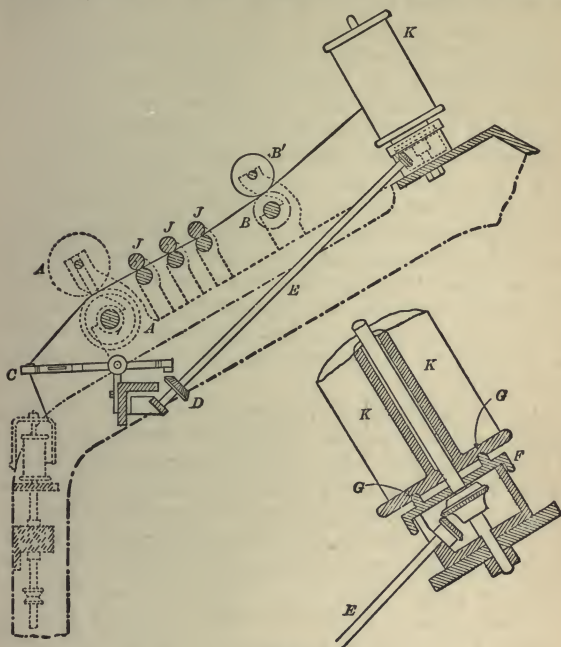

Fig. 48.

tion, it will be seen that as the roving is drawn off the bobbin the wheel D turns slowly round. But suppose an end breaks, the inner end of the lever C being slightly heavier, falls, and engages the teeth of wheel D, stopping its further revolution, and therefore that of the bobbin, which consequently delivers no roving, thereby preventing the formation of laps and waste. The feed-

rollers B B continue to work, but being smooth, the roving slips between them, and is consequently not broken. It might be thought that there is a defect here in the friction of the rollers on the roving, but we are informed that even with the softest Botany roving at present spun it is found not detrimental to any appreciable extent."

The principle of Messrs. Crossley and Sutcliffe's patent is very similar, but is applied to the top back roller, which is caught at one side by a lever when an end breaks. They also use two bottom back rollers, set rather far apart, so that the top one sinks in between them, and gets a firm grip of the roving, and when it is standing prevents it from being drawn through. At the present time when economy in production is so necessary, other attempts at stop motions are sure to be made, for when waste occurs in the spinning process it is not merely the material that is depreciated in value, but the cost of bringing it to the stage of roving is entirely thrown away.

146. **Worsted Mule Spinning.**—In the preceding chapter we described the principle of what is known as "French Drawing." It is necessary to say a few words here on the process which follows it, mule spinning. So far as the drafting of the yarn on the mule is concerned, it is in every way the same as in throstle spinning; there are the back and front rollers and the carriers in between. They are placed differently, being in the mule all horizontal, while in the throstle they are set at an angle of about  $45^{\circ}$ . But this in no way affects the work. Similarly with the throstle, the twist is being put into the yarn all the time the rollers are delivering, and during the same time the carriage must, of course, be travelling outwards to keep the yarn stretched. So far it is hard to say where the difference in principle is between the mule and the throstle, for the worsted mule is entirely different to the woollen mule, to which we shall refer later on; the latter has only one pair of rollers, the draft being obtained between the

spindle and rollers during the second half of the journey of the carriage when the rollers have ceased to deliver ; but the former closely resembles the cotton mule, the draft being entirely obtained by the rollers, and the spindle being only used for twisting and winding. When the carriage comes to the end of its journey, the counter-faller wire drops, and the yarn which was partly up at the top of the spindle to allow the twist to be put in, is now guided to its proper place, and the spindles, which had stopped for a moment, begin to wind on the yarn as the carriage returns to its starting point at the rollers. Now the difference between mule and throstle yarn spun off the same wool to the same counts is that the former is more bulky, more spongy than the latter ; and when it is woven it makes a softer, fuller piece of cloth, one which seems to have more body in it. The reason for this seems to lie partly in the previous drawing, and partly in the spinning. As we have seen, the French drawing has no twist to put into the slubbing ; it rubs it, and thus is always working the fibres sideways, as well as pulling them lengthways. This will help to make them round and springy, instead of flat and dead, and thus give a fuller thread. The same is seen in the spinning. On a throstle frame the yarn is first passed through and rubbed against the "pot-eye" of the wire-board, and then tightly wound round a hard bobbin, the whole thing being done in 7 or 8 inches at the most after it leaves the nip of the rollers. In addition to this, on a flyer frame the yarn is twisted round the wing, and through the flyer eye, while in a cap frame it is whirled round in the air, and then drawn under the hard edge of the cap bottom. Every one of these operations must have a distinct effect in flattening the yarn, and in stretching it, thereby taking out a large part of what little elasticity was left after the drawing. In the mule all this is avoided. From the time of leaving the rollers to being wound on to the bobbin the yarn touches nothing ; one small part of it is constantly

slipping over the spindle-point, but this is only an inch or two out of a reach of about four feet, and therefore can have no effect on the whole. Nor is there any severe tension. The carriage goes at the same speed as the rollers, and just keeps the yarn level without stretching it at all; and at no period does the drag alter in the least degree, whereas in the flyer frame it is never the same for five minutes together. The whizzing through the air caused by cap spinning is also avoided, for instead of describing a large circle as cap yarn does, it revolves to receive the twist almost on its own axis. It cannot fly round in a wider circle, because the carriage travelling keeps it tight. The result is that for each journey of the carriage we have, say, four feet of yarn in its natural state unrubbed and unflattened, with as much of the elasticity and spring of the wool preserved as possible. Where, therefore, it is of the first necessity to have this soft bulky yarn, the mule must have the preference, whether the yarn be spun in England or France. Where economy is more important, the balance seems to incline to the cap frame, for mules take up just twice as much room, do not turn off the same weight of yarn per spindle, and require men and boys to mind them. To set against that loss, the same quality of wool can be spun to a higher count on the mule than on the throstle, which in many cases is a very great advantage. But as in drawing, so in spinning. The style of frame used for spinning must ultimately depend on the sort of yarn that is wanted, and this, rather than any other considerations, will determine whether the worsted mule is to take its place along with the throstles in English mills.

147. **Calculations for Yarn.**—It remains only now to give the calculations for the weights of worsted yarns. The method on which the counts are reckoned is very simple. In every hank there are 560 yards, and the count of the yarn is the same as the number of hanks per lb. avoirdupois. Thus 1's is 1 hank of 560 yards per lb.; 36's is 36 hanks of the same length per lb. A

gross is 144 hanks, and therefore the weight of the gross varies with the count. To find the weight of one hank, divide the count into 256 (the drams in 1 lb.). Thus,  $256 \div 36 = 7.11$  the weight of one hank. To find the weight of a gross divide the count into 144. Thus  $144 \div 36 = 4$  lbs. It will be found that if a number of yards the same as the count of the yarn be weighed, they will be the same weight whatever be the number; thus, 1 yard of 1's, 36 yards of 36's, 60 yards of 60's, all weigh alike, and the weight is  $12\frac{1}{2}$  grains troy. This is called the count weight. To be more accurate, it is better to weigh half a hank or 280 yards, which can best be done by reeling 40 yards of each of 7 bobbins, and its weight will be half 256 divided by the count. Another test is to divide 1,000 as a constant number by the number of hanks per lb. avoirdupois, and the quotient will be the weight of 80 yards in troy weight. Then 80 yards can be reeled and weighed to see if correct.

It may be useful here to give the tables for reckoning yarn of other materials and countries. Woollen yarn is reckoned in skeins, the scale being based on the number of yards per dram. Thus, 5's or 5-skein yarn contains 5 yards per dram, or 80 yards per ounce, and so on for any count. This is the Leeds and Yorkshire system, but there are others in other districts which are irregular and not based on any good principle. For cotton yarn the scale is:—

$1\frac{1}{2}$	yards	=	1	thread			
120	,,	=	80	,,	=	1	lea or rap
840	,,	=	560	,,	=	7	,, ,, = 1 hank.

The counts signify so many hanks per lb. To find the count of any yarn, weigh any number of leas, add three cyphers to the number, and divide by the weight in grains, and the result is the count. If 1 lea weigh 20 grains, then  $\frac{1000}{20} = 50$ , which is the count of the yarn. It will be seen that as a worsted hank is 560 yards, and a cotton one 840 yards, one yard of worsted

will weigh the same as one and a half of the same count of cotton.

For English linen-yarn the scale is :—

$2\frac{1}{2}$ yards =	1 thread			
300 „ =	120 „ =	1 lea		
3,000 „ =	1,200 „ =	10 „ =	1 hank	
60,000 „ =	24,000 „ =	200 „ =	20 „ =	1 bundle.

For Irish linen-yarn :—

$2\frac{1}{2}$ yards =	1 thread			
300 „ =	120 „ =	1 lea		
3,600 „ =	1,440 „ =	12 „ =	1 hank	
60,000 „ =	24,000 „ =	200 „ =	$16\frac{2}{3}$ „ =	1 bundle.

The count in both cases is the number of leas per lb., thus 40 leas = 1 lb. = 40's counts.

The following table of lengths of hanks of different yarns in different countries appeared in the *Textile Manufacturer*. It is given for single yarn “in the grey,” *i.e.*, undyed and unscoured. We shall see later on that yarns lose a good deal in dyeing, scouring, and also in twisting; and therefore it is impossible to tell, after the two former processes at any rate, what the actual count of the yarn originally may have been.

		YARDS.
Worsted yarn.....	German .....	840
„ „ (weft) ..	English .....	560
„ „ .....	French.....	787
Woollen „ .....	Prussian .....	1,604
„ „ .....	Saxon .....	495
„ „ .....	Austrian .....	1,500
„ „ .....	Elbeuf .....	3,938
„ „ .....	Sedan .....	1,633
„ „ .....	English .....	560
Mungo „ .....	German .....	1,604
Vigogne „ .....	„ .....	407
Cotton „ .....	English .....	840
„ „ .....	French.....	1,094
Flax „ .....	English .....	300
„ „ .....	French.....	300
„ „ .....	German .....	300
„ „ .....	Austrian .....	12,268



	YARDS.
Silk, Organzine or Trame.....	525
Spun Silk.....	840
„ .....Swiss .....	547
Mohair Yarn .....	560
Alpaca „ .....	560

---

## CHAPTER IX.

### WOOLLEN CARDING.

148. **The Woollen Trade.**—So much has been written, both recently and in past times, on the processes of woollen manufacture, that very little can be said here which has not been said in one form or another before. With worsted the contrary is the case. Though the operations of the worsted spinner are much more numerous and complicated than those of the woollen spinner, very little has been written on the subject; and we have, therefore, explained at considerable length the principles of the various processes of the trade. But though the preliminary operations in the woollen trade previous to spinning may be said to consist merely of carding, they are none the less important; for where there is only one process, if it be spoilt, the whole work is ruined; but where there are many, the faults of one may be covered by those which follow. In the woollen trade everything depends on the carding, and the workman must therefore be thoroughly acquainted with every detail of his machines.

149. **Shake Willey.**—We have seen the wool washed and dried, and have now to work it up ready for the scribblers or cards. In order to free it from any dirt or dust which may still be adhering to it, and also to shake loose any matted pieces, the wool is usually passed through a shake willey or willow, which, without doing anything that can be called carding, opens it and makes

it light. Fig. 49 represents one of these machines in its front view and also in section. The wool is placed, an armful at a time, on the grating, D, which is then lifted up by the handle so as to bring it close to the spiked swift seen inside, which revolves 400 or 500 times a minute in the direction shown by the arrow. The three spiked workers, c c c, revolve above it in the opposite direction, and as the wool is carried up by the swift rapidly past them it gets torn and shaken. As it falls again it is beaten against the grating, D, and a great part of the dirt and dust in it falls through into the box beneath. There is also a chimney at the back with a circular fan at its lower end driven very rapidly by the shaft E, which blows the dust out, and thus between the two the wool is greatly cleaned, and yet is very little, if at all, broken. This machine is often used before washing for dusty wools, such as skin wool, and by its means large quantities of lime and sand are blown away, and a saving in soap is effected. No wash-house where dusty wool is used should be without this machine. To prevent the dust coming out in front a curtain is attached to the front bar of the grating, D, which covers the mouth when the grating is raised. The only objection to this machine is the danger to the workers, for the swift is not stopped with each change of wool. The man who feeds it simply lets down the grating when he thinks the wool is sufficiently shaken, and carefully putting his arms inside gathers up all the wool that is lying on it, and then throws in another armful. It is clear that want of care would cause a very serious accident in this case, and to remove the danger another machine has been invented which is fed by an apron, and which automatically empties itself into another apron at fixed intervals. It is not so simple as the above, and more costly, both serious drawbacks to its adoption.

**150. Blending and Oiling.**—When the wool has been thus willeyed, the important process of blending and oiling takes place. We have seen that in worsted draw-

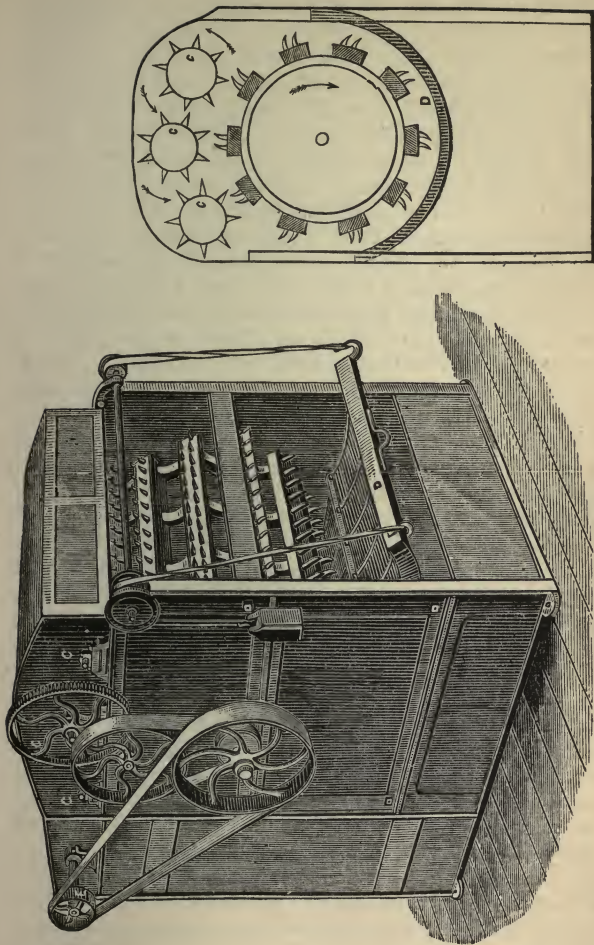

Fig. 49.

ing the blending can most conveniently be made in the top, that is, after combing ; but here it must be made before carding, or not at all. It is one of the most important operations in the whole manufacture ; for if not properly done, the thread will be uneven, and the different qualities or colours not properly mixed. Blending may mean many things. It may be different colours of dyed wool, or wool and shoddy, mungo or flocks, or wool and cotton, or wool and silk, or all these together. But whatever the materials may be, there is one elementary rule to be followed, viz., to spread out each layer of material as thinly as possible on a large clean floor, laying one over the other, so that no great thickness of one material can ever be found together. As each fresh layer is put on the whole should be beaten down with sticks to press it into those below, thus helping the union of the sorts. When the pile is made—we are assuming now that it is all of wool in some shape—it is taken away by pulling off one side, and not off the top, and is then passed through a mixing machine, which is another form of willey, but which is sometimes called a “fearnought,” presumably because it is so powerful that it can tear up whatever is put into it. After this operation the blend is again spread on the floor and oiled, and, if necessary, also watered ; but it is better to have the wool damp from the dryer rather than to dry it thoroughly and wet it again, as a second wetting is never so uniform as the moisture left in after washing. The oil, of which we have spoken in Chapter III., is sprinkled on the wool by means of an ordinary watering-can with a T-shaped rose—if the expression can be allowed—and as each layer is spread on the floor more oil is sprinkled. The quantity used varies very much, but for blends half wool and half shoddy 10 lb. of oil per 100 lb. of wool is a common allowance. When the shoddy is increased more oil must be used to help the spinning. The blend is again passed through the fearnought, and is then ready for scribbling. Some persons prefer to oil the blend as it is first made,

and probably there is not much difference in result between the two methods, though by the former it seems as if the wool would be more ready to mix than when it was made rather sticky and heavy with oil.

**151. Mixing Wool and Cotton.**—For mixing wool and cotton together for Vigogne yarn, such as is largely made in Belgium and Saxony, the method is different. The wool must be freed from all dirt, etc., by willeying and thorough washing, it must then be oiled and again willeyed to spread the oil over all the fibres, and it is all the better for being passed through a preliminary carding machine. The cotton, which must be clean and long in staple, must also go through an opening machine and a card to straighten the fibres. The requisite quantities are then weighed and blended together in the usual way. The cotton absorbs a little oil from the wool, but if it were not for the preliminary working of the latter, the cotton would absorb nearly all. The blend thus made should be passed more than once through some machine like the fearnought to have it well mixed before carding. These somewhat elaborate mixings are hardly needed where just a little cotton is mixed with the wool, as is very often the case in those mills where cheap cloths are made, but still the wool blend must always be oiled first, and willeyed once before the cotton is added. In mixing wool and silk waste the same course must be followed, and care must be taken that the oleine oil is of the best quality, and free from acid.

**152. Care Needed in Blending.**—It is not enough to see that the blend is properly made. That is the duty of the workmen; but the master must take care that suitable materials are used. Naturally much depends on the style of yarn desired, but it is a good rule not to mix different qualities too much. A short fine wool is lost among that which is long and strong; and though it may have its use in feeding the yarn and making it look bulky, its full value is partly lost. Another point to be attended to is not to run the quality down so much as to

have a bad spin and much waste, that is, not to try and spin the wool beyond its limits. Waste is such an expensive item, that it is often cheaper to use better material at a greater initial cost, and thus make a greater percentage of yarn and less waste. It may be difficult

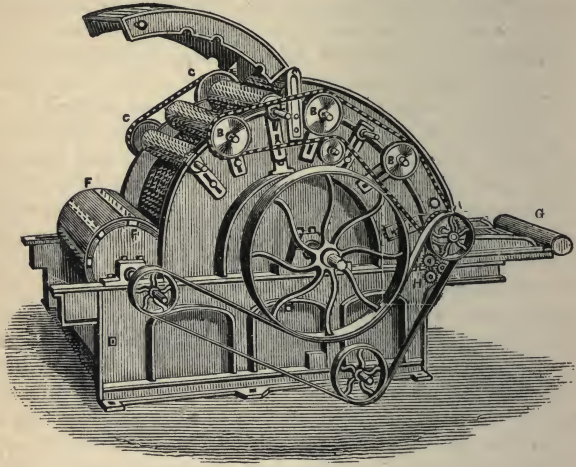

Fig. 50.

to realise the importance of careful blending when all the wool, etc., is one colour, but if three or four shades very different from each other are blended imperfectly as an experiment, the result will be a streaky yarn and a spoilt cloth. The damage is then visible, which is not the case when all is one colour; but this test shows that the yarn, when the blending is imperfect, is streaky and unequal, whether it can be seen or not.

153. **Mixing Willey.**—The fearnought willey, to which reference has been made, is shown in elevation in Fig. 50 and in section in Fig. 51. The feeding apron is at G, the feed rollers at H. The swift, which is covered with strong tenter-hook teeth, revolves rapidly, carrying

the wool upwards to the workers, B B, by which it is caught and drawn out. The strippers, c c, in turn take it from the workers, both of these revolving the opposite way from the swift, and the swift again catches it and takes it on. Finally, a hollow drum, F, with straight spikes on it, beats the wool off the swift, and throws it out into a box at the other side.

154. **Shoddy, Mungo, and Flocks.**—A few words must here be said on re-manufactured fibres, known to the

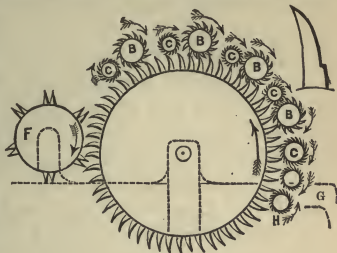

Fig. 51.

world under the common name of "shoddy." There are few more unreasonable and foolish prejudices than that against shoddy, and so far from it being a term of reproach, it should really be one of praise; for the man who first brought shoddy into use has conferred an incalculable benefit on the world, and enabled millions of persons to be warmly and cheaply clothed, who must otherwise have been shivering with cold. It would be as reasonable to despise paper-makers because they use up linen rags, or to despise dyers who use colours made from coal-tar, as to despise manufacturers who use up waste woollen rags as shoddy. It is said that 125,000,000 lbs. of shoddy, mungo, etc., are manufactured into cloth every year in England alone. If this immense quantity were wasted, it is difficult to estimate the increase which would take place in the price of wool, and the consequent dearness of cloth, but the result would be that countless persons would be unable to afford proper clothing. *Shoddy* is the worked-up waste of soft woollen goods which have not been milled and felted, such as stockings, flannels, and soft merinos, etc., and is also made from hard spinning waste. *Mungo*, on the other hand, is made

from hard spun and felted cloth, such as broad cloth, and generally all cloth used for men's clothing which is free from cotton. *Extract* is the wool derived from waste materials which have had cotton or linen in them; and *Flocks* are the waste from the finishing machines in cloth mills, and are little better than dust. Shoddy is the best of all these, being longest in fibre, but when it is examined under a microscope, it is seen that the scales are destroyed to a great extent, and the fibre uneven as if it had been stretched too much in previous operations. Consequently it is not so good for spinning or for felting as new wool of the same length; but as it is very short, it is found to work up and be held sufficiently well by a very little new wool mixed among it. As shoddy is made largely from combed wool, it would appear that the fibres are, to some extent, damaged by the many operations of the worsted trade. The best and longest shoddy is made from hard worsted spinning waste. Mungo is shorter, and has almost to be ground up if the cloth from which it is made has been much milled, and it consequently is not so valuable. It is a saying, however, in the district where it is used, that any fibre can be spun if it only be long enough to have two ends, and this is apparently true from the fact that waste which seems little more than particles of dust can be mixed with a little wool, and made into a handsome, warm, and really substantial cloth. Extract varies in length according to the cloth it is made from. It is extracted by the method of carbonisation previously described, either before it is re-manufactured or afterwards. In the former case the cotton is first burnt out, and the wool which is left is worked up like shoddy; or the whole material is worked up and the cotton from it only extracted when the cloth is made. But this latter can only be done when there is little cotton in it. Flocks, as already stated, are made by the cloth finishing machines, and are like powder when made. They are chiefly used for stuffing mattresses, but can be mixed in with shoddy



and wool for low thick cloths. The machines by which the first three of these materials are made are various. The one for opening the looser waste is called a Garnett, from the name of its maker, and is in principle like a fearnought, with two swifts and two sets of other rollers, but is covered more closely with strong teeth. The machine for making mungo is popularly known as a "devil" from the way in which it tears up and maltreats whatever it gets hold of. In effect they are all much alike, and do not need further description. The manufacture of these waste products is a trade by itself, and the woollen spinners buy their shoddy, etc., in the same way as they buy their wool.

155. **Burring Machine.**—We have assumed so far that all the wool used for the blends of which we have spoken is free from burrs and all other vegetable matters. But this is not the case until something has been done to remove them. In the wool-sorting a good deal can be done, but when wool is full of burrs, seeds, etc., and is what is generally called "shivey," sorting and shaking can do little. The wool must either have the burrs, etc., chemically extracted, or be passed through the burring machine. The former is the best way when the "shivs," etc., are small, the latter when there are only burrs to contend with. Some object to extracting, because it damages the fibres, making them harsh and brittle, but when carefully done, they do not suffer; and on the whole it is the most economical way. The burring machine is, however, so extensively used, and is so different in its construction from all the class of willeys, that it must be described. The outside is very similar to a fearnought, and therefore need not be shown, but a view of a section of the inside is here given (Fig. 52). The wool is fed in at the right-hand side, and received between two small rollers, which pass it on to a spiked drum or beater, A, revolving downwards. This separates it and lays it on a travelling apron, B, which carries it to C, a similar brush. This brush lifts it up to the swift, D, which is curiously constructed.

It is covered with steel plates  $1\frac{1}{4}$  inch wide, which have fine steel needle teeth sticking out of them on the side towards which the swift revolves. These needle teeth slant slightly upwards, but do not rise above the surface of the swift; therefore they are not shown in a sectional diagram. As the swift revolves quickly the reverse way of the circular brush, *c*, and as the bristles of the latter

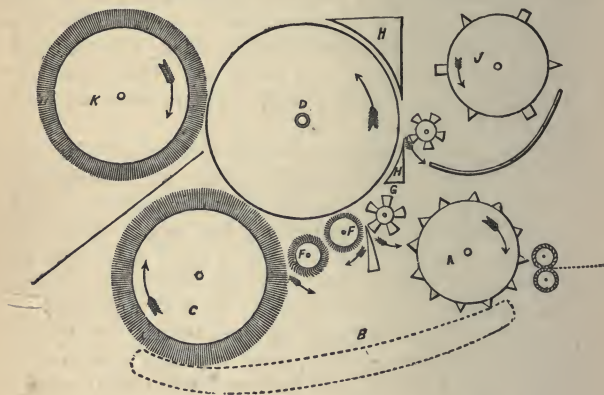

Fig. 52.

touch the face of the former, the needle teeth catch the wool and carry it on. The two small rollers, *F F*, take any wool still remaining on *c*, and carry it to the swift; the lower roller, *F*, being covered with steel card clothing, the upper one being a stiff brush to press the wool on to the needles of the swift. The wool is now in these needles and the burrs are hanging on outside, when the swift passes the first burring roller, *G*, which knocks off a number of the burrs. The longer the wool the nearer must the burring roller be set to the swift; the shorter it is the farther off must the roller be. This is because the long wool has a better hold of the needles, and can bear to be beaten better, and also because the

long wool has a firmer hold of the burrs. But with short wool the roller must be put back or it would knock out the wool along with the burrs. For very short wool this roller is not used at all. The wool then passes under *н н*, called ledger blades, which are flat pieces of iron, made pointed. Between these two is the second and more powerful burr roller, which knocks off all the burrs on to a grating, through which they are beaten by the roller *ж*. Passing on, the wool meets another circular brush, *к*, which revolves more quickly than the swift, and so brushes the wool out of the needle teeth and throws it out into a box beyond. Of course a good deal of wool adheres to the burrs, but this can be extracted by carbonisation in the usual way.

156. **Card Feeding Machines. Evan & King's.**—We now have the wool ready for the scribbler, or first carding machine, and will describe the apparatus for feeding it before the working of the machine as a whole, or its various parts. The old-fashioned way was to spread the wool by hand on the apron at the back of the feeding rollers. A pair of scales was fixed to every card, and the minder had to weigh each lot of wool as he or she spread it on the apron. The apron was marked in certain spaces, so that a given weight of wool might be spread on a given space. This depended, of course, on the attention and care of the minder, a very doubtful quantity, the only certainty being that it would be deficient, and therefore the result always was that the feeding was irregular and the delivery at the other end equally so. This did not matter so much in carding before combing, or even in carding before drawing, for low worsteds, because the drawing levelled the sliver. But for woollens it was a very grave fault, as uneven work at the beginning was felt at the condenser, and therefore in the yarn. A mechanical feeding apparatus was therefore necessary, and the one most used in this country is the invention of Messrs. Evan & King, of Glasgow, now made by Mr. John Tatham, of Rochdale.

The principle on which it works is that a large hopper is filled with wool; at fixed intervals a drum with beaters attached to it revolves rapidly against an opening near the top of the hopper on the side next the card. These beaters knock down a given quantity of wool into a tin scale or trough, which reaches across the card feed apron. When a fixed weight has fallen into the scale, the beater automatically stops; the tray is, by a contrivance of wheels, tilted up so as to drop the wool down on to the apron; and in a short time the tray rights itself, and the beating drum re-commences. This has two drawbacks; one, that the wool may not always fall into just the same space on the apron as it should do, and the other, that if the wool be lumpy in the hopper, if, for instance, there is a lump of waste roving or card waste in it, this piece may be beaten out all together into the scale, thus making up the required weight, but really falling all on one place on the feed apron. These faults are not very serious, but they are enough to make another machine bear away the palm for all except blends which have hardly any wool in them, and are chiefly shoddy, etc.

#### 157. Bramwell's Weighing and Feeding Machine.

— The Bramwell automatic weighing and feeding machine, shown in Fig. 53, is an American invention, and is described by its inventor somewhat as follows: The wool is put into a large box, A, having a grating at the bottom for the exit of refuse, and an apron, C, covered with sharp spikes revolving vertically, but with the upward motion in the box, A. The sharp spikes lie nearly along the plane of the apron, but project enough into the wool to carry a considerable quantity up with it. Near the top it is brought into contact with a slowly oscillating comb, A<sup>1</sup>, which has a slow but long sweep down the apron. The teeth of this comb carry off the surplus wool from the apron, dropping it back among the rest in the box, and what is left is evenly distributed over the apron. This is carried over the top roller and

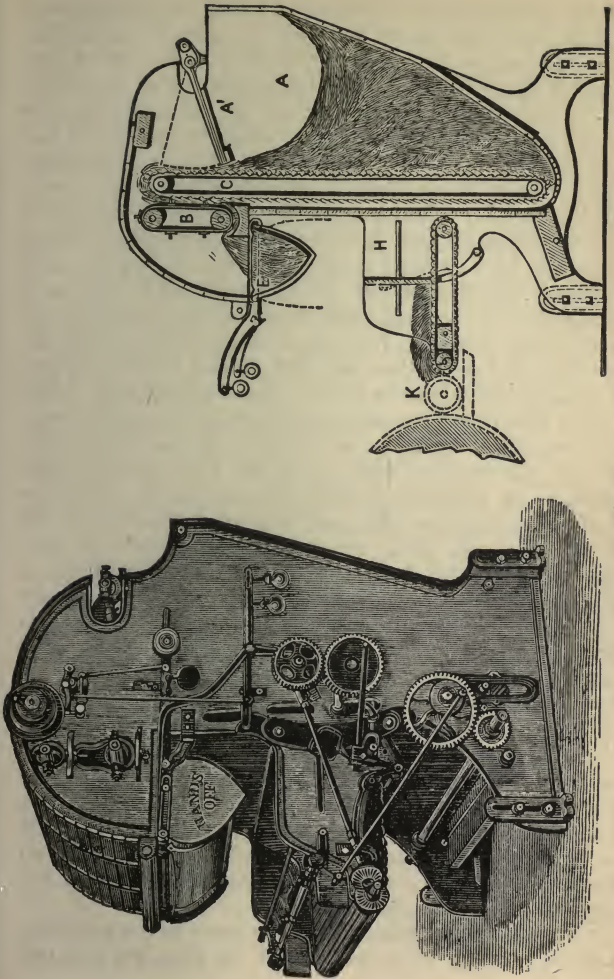

Fig. 53.

there meets another apron, B, which revolves more rapidly and sweeps off the wool under its bottom roller into the scale or trough, E. This scale is formed of two curved wings held together by weights, and the whole suspended on steel knife edges, and balanced with weights which can be fixed to weigh any weight required. When the scale has received its proper amount, it liberates a small trigger which causes a projection to catch on one of the small teeth of a revolving disc connected with a novel automatic clutch, which disengages the driving belt (not here shown), working the toothed apron, then instantly stopping further delivery of wool to the scale. The wings of the scale open in a definite time, and the wool drops on to the feed apron well opened out by the combing it has had on the first spiked vertical apron. The scale then closes and the process begins again. But in the mean time the partition, H, which, when the wool fell was back against the frame of the box, moves forwards, pushing the wool along the feed apron to the position in which it is here shown, and then it moves back for another supply, and the wool passes on to the feed rollers, K. This gives a perfect supply of well opened wool, and is free from the defects of Evan & King's feeder, for it feeds regularly a given quantity into a given space in a given time. Owing to this great regularity and to the well opened state of the wool, the cards are said to do from 20 to 30 per cent. more work than under the old system of hand feeding. That it deserves the praise given to it we know from observation. Whether it will do for blends made almost entirely of shoddy, etc., is not quite certain, as the fibres would be so short that the comb, A<sup>1</sup>, might knock too many of them off the apron, C, and thus the supply of wool to the feed rollers might not be regular. For all longer wool, and for cards in the worsted trade, it is undoubtedly a great improvement.

158. **The Scribbler.**—We now come to the scribbler, and to give an accurate idea of its form we give two

illustrations, the first a sectional side view (Fig. 54), without wheels or belts, to show the position of the rollers relatively to each other. It represents a card made by Houghton, Knowles & Co., of Gomersal, near Leeds, consisting of breast and two swifts, with three workers and strippers on each swift. Its feeding apron is shown at the left-hand side, the portion marked Blamire's Feed being the finishing end of the card. The other illustration (Fig. 55) shows a similar card in perspective from the other side, made by John Haigh & Sons, of Huddersfield. Its feeding apron is shown at the right-hand side; thus the two plates show different sides of a card. Each machine is lettered the same. N is the feed apron, at the end of which are three small rollers to receive the wool. B is the licker-in, and A the angle stripper between the licker-in and the doffer. The other two rollers farther on, marked A, are angle workers between the doffers and the following swifts. The rollers marked s are strippers, w are workers, F fancies, and D doffers. It may be noticed that in Fig. 54 the ends of the workers are large, while in Fig. 55 it is the ends of the strippers which are so. This is because in the former we see the wheels by which the workers are driven, and in the latter those by which the strippers are driven. The driving apparatus is seen in the latter. The main driving belt is on the other side, and turns the first swift, which drives the breast on that side also. The first swift turns the second; the breast and each swift turns its own doffer by a belt and two-toothed wheels, the smaller and lower one being the change wheel which regulates the speed of the doffer. The workers are driven on the other side by a chain that works on star wheels—that is, wheels with spokes standing out to catch the chain, from the doffer ends, and the strippers are driven by a long belt that winds in and out on the side here shown. Some cards have three swifts, with other rollers to match, and some have even four. In both cases the driving is the same.



Fig. 54.

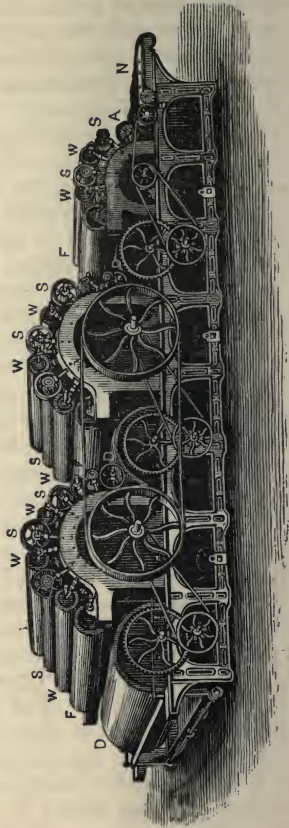

Fig. 55.



159. **Functions of the Various Rollers.**—The following diagrams (Figs. 56, 57) show so well the action of the various rollers in opening the wool, and the passage of the wool through the cards, that they are worth reproducing from the *Textile Manufacturer*, along with the description. The process is well known, and has been often described by other writers; but any book on the

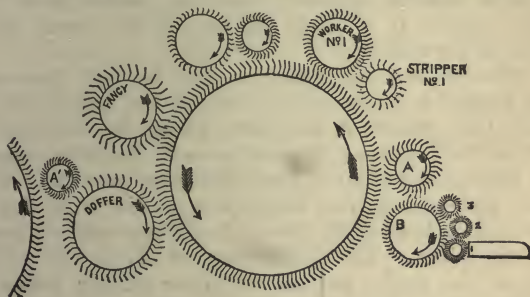

Fig. 56.

subject would be incomplete were it omitted, and it is here very clearly given:—

“The wool, weighed out and spread evenly on to the lattice feed board, passes between Nos. 1 and 2 feed rollers, where it is met by the licker-in, B, which, wholly stripping No. 1, commences the carding process in conjunction with No. 2, taking a part from, and leaving a part on it, which latter part is taken off and delivered to the licker-in by No. 3 feed roller. A, the angle stripper, by its quicker speed, clears the licker-in of the wool, to give it up immediately to the cylinder, which is rushing past at a speed of from 50 to 70 revolutions per minute, or a surface velocity of about 800 feet per minute. With the impetus derived from its speed, the cylinder carries forward the wool into the slowly retreating teeth of the first worker, which is revolving about six times per minute. Here we have the first real

combing process, the quicker speed of the passing cylinder causing the different cards to work point against point. By this combing, worker No. 1 gets its share of the wool, which is brought round and given up to stripper No. 1, to be in its turn relieved by the active cylinder. The second worker and stripper now repeat the task first performed by their companions, and the cylinder, regaining possession of the wool, carries it a little farther to the next roller, which is the fancy."

The duty of the fancy is not to work the wool, but merely to raise it up out of the wires of the swift, into which it has been forced by the velocity of the swift passing the strippers. For this purpose the wires of the fancy are set a little way into those of the swift, and as its surface velocity is greater than that of the swift, it brushes up the wool a little to make it ready for the doffer. The doffer revolves slowly the reverse way of the swift, and as the latter quickly passes, it deposits its wool on the doffer, which carries it round till in its turn it is relieved by the next angle stripper

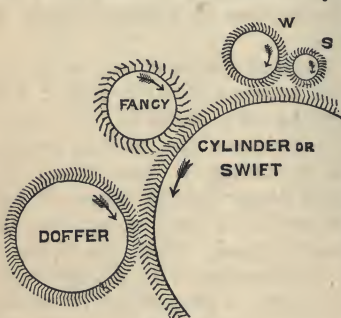

Fig. 57.

A<sup>1</sup>, which strips the doffer and passes the wool on to the next swift. Fig. 56 shows the breast and its workers, etc., but the principle is the same as when we came to the swifts proper. In Fig. 57 a portion of a swift is shown with one worker, stripper, and the fancy and doffer belonging to

it, and will make perfectly clear the action of the various parts, and the way the wires are set. The swift bears the wool to the worker which carries it

round away from the former till the stripper removes it and gives it back to the swift again. In each of these three changes the fibre is combed out, first by the worker as the swift goes by; secondly, by the stripper as it takes the wool from the worker; and, thirdly, by the swift as it in turn strips the stripper. The fibre is then probably so well straightened that it lies flat on the swift till the fancy raises it, and the doffer finally removes it altogether.

160. **Relative Action of the Card Wires.**—It will be clear that the success of all these operations must depend on the way in which the wires are set in the cards, and the way in which they point and work on each other. Owing to the form of the card teeth, which are made of wire with a bend about half way down them, as in Fig. 58,

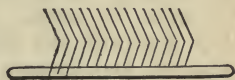

Fig. 58.

there is in every card what is called the point side and the smooth side, the former being the side towards which the wires point. If the card roller revolves with the points first, it presents, of course, the sharp points of countless wires, which catch at whatever they pass. If it revolves with the bend or smooth side first, it presents no catching surface, but acts like a brush. There are three ways in which the cards work on each other:—Firstly, point can meet or rather overtake and pass point; secondly, point can pass smooth side; and thirdly, smooth side can pass smooth side. The result to the wool depends on which of these three is done. We will take each roller and see its effect in working. The swift revolves rapidly, point first, carrying the wool forwards. Its points meet or overtake and pass the points of the worker, and the wool is combed between them, being left on the worker. This is called working point against point. The stripper, which goes quicker than the worker, is said to be working point against smooth side, for it revolves with its points first against the smooth side of

the worker, and in doing so it combs all the wool off the latter. The swift again operates in the same way on the stripper—namely, works point against smooth side, and also combs the wool off the stripper. Arrived at the fancy, we find it working with its smooth side to that of the swift, because it revolves faster than the swift, and therefore it does no combing, but merely brushes the wool up from the wires of the swift. A comparison here between the worker and swift on the one hand, and the fancy and swift on the other, shows the curious fact that though their effects are entirely different, they appear quite correctly in Figs. 56 and 57 to be in similar positions to each other. It is therefore simply owing to their relative speeds that the difference is made. Because the worker goes slower than the swift, the latter in effect runs point to point with it; and because the fancy goes faster than the swift, they run smooth side to smooth side, and the fancy acts only as a brush. If the relative speeds of the worker and fancy were changed, the worker would become a fancy and the fancy a worker. Coming at last to the swift and doffer, we see they work point to point just like the swift and worker, and hence the doffer receives all the wool. All this is rendered possible by the swift revolving in one direction, and the other rollers in the reverse; and therefore, whenever any roller and the swift are working together they run in the same way as a pair of press rollers, drawing the wool between them and sending it in the direction of from the beginning to the end of the card.

161. **Setting the Rollers.**—The foregoing descriptions should make clear the principle of carding; and it remains now to be stated how the various rollers should be placed or “set” relatively to each other. The old method of setting was to judge by the eye whether the rollers were near enough to each other, but, considering the delicacy of the operation, and the disastrous results to the work if the setting be either too near or too far

apart, it is better to use a gauge. These are made of thin flat pieces of steel, an inch wide and about eight inches long, varying in thickness from No. 24's to No. 32's cardmakers' wire-gauge counts, in mills where fine wool is used. For coarse wools thicker gauges are needed. On the breast the workers, strippers, and doffers are set farthest off, on the first swift they are set nearer, and so on, growing nearer and nearer as the carding advances, and the wool is better worked. The following recommendations may be taken as an example of the ratio of distance which the rollers bear to each other :—

“Set the licker-in, B, a quarter of an inch from the cylinder ; the bottom No. 1 feed roller so that a No. 24 gauge will pass between it and the licker-in ; feed roller No. 2 is set the same distance from the licker-in, and slightly resting on the feed roller No. 1 ; feed roller No. 3 set so that the same gauge will pass between it and No. 2, and between it and the licker-in. The angle stripper, A, must be set so that a No. 26 gauge passes between it and the cylinder, and so near the licker-in as to clear the wool from it. The strippers and workers should be set so that No. 26 gauge will pass between them and the cylinder, the strippers to the workers till you hear a slight ‘whizz’ caused by the abrasion. The ‘fancy’ must be set to dip slightly into the cylinder, and will thus keep a working point on the latter. The doffer to be set to the cylinder with a No. 26 gauge, very close fit. This system of setting continues throughout all the remaining parts of the machine, increasing in nearness at each succeeding cylinder. For example, No. 1 or first cylinder after breast part may be gauged with a No. 28, and No. 2 with a No. 30 ; the first cylinder on the condensing engine which comes next with a No. 32, and the last cylinder with a No. 33 gauge. The setting given is for fine and short wools ; for long and strong wools the setting must not be quite so close as the foregoing.”

It will thus be seen that nothing actually runs in, or even touches, the swift, except the fancy. No rule can be

definitely given as to its setting. The carder must judge by ear and eye, and may gradually set it closer as it becomes more worn. The belts should always be put on the cards before setting, for if they are tight and put on afterwards, they may slightly alter the distances and spoil the setting. As the doffers take the wool off the swift they should be set very close, but must not run into it. Regarding the last doffer of the entire set, the ring doffer, we do not say anything here. It will be mentioned later on. In the condensing card, the swifts can be set rather nearer together than in the scribbler, or than in the intermediate card if the set contain three. These remarks apply equally to worsted cards.

162. **Lickers-in and Breast.**—A few words may now be said about the functions and special points of each part of the machine. The first in order are the small and often neglected feed rollers and licker-in. It is exceedingly necessary that these should be true and level, and set straight to the breast or swift. If they feed unevenly, the delivery at the other end cannot be perfect. As they are small in diameter they should all be made of iron or steel, wood being apt to warp. Their teeth must be very strong and upright, for they have to hold the wool when first caught by the breast or swift, and thus have to bear a great strain. They are generally covered with diamond point wire. The two sorts of clothing used for the strong rollers before the breast are called diamond point and needle point. The latter, as the name implies, is pointed like a needle. The wire is round, and as it is cut into lengths for the card cloth each end is sharpened *all round* till a point is obtained, which is sloped up to on every side as is the case in a pin or needle. Diamond point is sharpened on one side only; that is, the end is ground down all on one side, so that while the wire is quite straight up to the very point on the lower side, it is bevelled off on the upper one to make the wire sharp. The size of the wire must depend on what is to be carded, but 22's is common for the feed

rollers, and finer counts for the others. The breast, when one is used, must also be covered with strong wire, between that of the licker-in and the first swift in thickness.

163. **The Swift.**—The main swift is, for some reasons, the most important part of the machine, as it certainly is the most expensive to cover and keep in order. It is almost always covered with sheets, and care must be taken that these are tight. From its great size, its superficial velocity is great, and therefore by centrifugal force its clothing has a tendency to become loose and baggy in the middle. When this happens, the sheets should be taken off at once and re-nailed, the swift itself being examined to see if it is still true. It is clear that as any part of a sheet which is loose must project out beyond that which is tight, the wires will be ground off by the rollers which it will rub against, and when it is again made tight, there will be a hollow in the same place owing to the wires being rubbed short. The swift does not do the main part of the carding; that is done by the workers and strippers. It really carries the wool forward to the workers and from the strippers. Hence, there is no advantage in running the swift too fast. It does not regulate the amount of work turned off, though it may help to regulate the carding the wool receives. But if it runs very fast, the fancy must run faster, too, and the result is an immense increase in waste, which flies all over the machines. To take the revolutions per minute of the swift, without considering its circumference, is, of course, absurd, though it is often done; it is the superficial velocity which is the real speed, and 1,000 feet per minute is quite enough for medium or even long wool, while for short wool and shoddy three-quarters of that is the outside that is needed.

164. **The Fancy.**—The fancy, as already stated, is merely used to brush the wool up from the wires of the swift to enable the doffer to take it. To do so it must have a greater surface velocity than the swift, but it is not necessary that the difference should be very great;

more often than not, the speed of the fancy is unnecessarily high, and much waste is caused. It is this waste from "fly" that makes carding so costly in the combed wool trade. In preparing there is practically no fly—merely dust falls out; but in carding before combing, or in carding by itself, the amount lost, or reduced to mere card waste, is very great, and the resultant cost of the "top" is increased. Too great care cannot be taken of the teeth of the fancy; they are long and elastic, having to serve the purpose of a brush. When once they are ground, they should remain sharp, and can be set closer into the swift as they wear down. The clothing must, however, be renewed long before they are actually worn down to any thing like the level of the wires on other rollers, for when they are enough worn to prevent them from being elastic, they either press too heavily on the teeth of the swift, wearing them out, or they do not raise the wool up enough for the doffer, and then the wool goes round and round. There are various sorts of fancy clothing now made, the object of which is to reach lower down into the swift with a few teeth than can be done with them all. A few wires are therefore inserted at intervals, projecting beyond the others, and the fancy is set so that they go very nearly to the bottom of the swift wires. Two of the leading sorts may be mentioned. One is to have perfectly straight pins at regular distances standing out about a quarter of an inch beyond the rest of the clothing, and fixed in the usual way in the same piece of leather or vulcanite as all the other wires. The other method is to have two strips of filleting, one the usual width, say,  $1\frac{1}{4}$  inch, with the ordinary wires in it, and the other a very narrow strip with one or two rows of teeth across which stand farther out. These are wound round side by side so that every alternate row projects; and as they are necessarily very slightly spiral in the winding on, the whole surface of the swift is covered as the fancy revolves. The two merits claimed for these are, firstly, that all the wool is raised from the swift at



each revolution and therefore all is received by the doffer, and none goes round the second time; and secondly, that in consequence of this the swift never needs cleaning or stripping, because there can never be any waste left in. These claims are well substantiated, and the fancies deserve much praise, for it is a great saving, both of time, wool, and card clothing, not to be obliged to strip the swifts. Many swifts are spoilt with bad stripping, the comb being pulled slanting towards the side instead of perfectly straight parallel to the sides of the roller and at right angles to the shaft. If they have a drawback, it is that they have a tendency to make more fly waste, and this must be guarded against by not running too fast.

165. **The Doffer.**—The doffer is second to nothing in importance. On it depends the amount of work turned out, or, in other words, the speed at which the wool travels through the card. The larger the doffer, or the greater its surface velocity, the quicker the wool passes. Of course it is the feed-rollers which determine the actual quantity put into, and therefore taken out of, the card. In the first place, the doffer should be as large as possible in relation to the swift. To increase the swift at the same time as increasing the doffer is, of course, no use, though it is sometimes done. But the object of a large doffer is to have as much of its surface in contact with the surface of the swift as possible, so that there may be more combing in the process of transferring the wool from the latter to the former. If it were merely a question of speed in delivering, a 20-inch doffer run twice as fast as a 40-inch one would do as well; but the doffer should be run very slow, and increase in size must make up for it. In the next place, the points of the doffer's wires must always be kept very sharp and smooth. They are very liable to wear by the action of the swift because, as will be seen from Fig. 56, representing the position of the rollers, the swift and doffer run point against point, and the greater speed of the former wears

away the latter. In order to keep them sharp, a little roller is often run on the top of the doffers; sometimes it is a small slow-going emery roller, sometimes a sort of short-wired fancy which brushes its wires and preserves the points. In any case, the points of the doffer's wires should be sharper than those of the swift, because the former has to receive the wool and the latter to part with it. The doffer after the breast and first swift may be clothed either with sheets or filleting, but the last doffer should have filleting to let the sliver come off with perfect regularity, and without the breaks in it which, as we shall see, sheets must always cause. Many carders, however, cover the last doffer of the scribbler with sheets; but in a worsted card this is never done.

166. **The Workers and Strippers.**—The workers are the main carders and must therefore be kept sharp and smooth; they should be as large as possible, and there should be as many of them on each swift as there is room for,—four is a common number. The larger their circumference, the more points will there be in contact between them and the swift, and therefore the more combing of the wool. They are often driven by chains off star wheels on the doffers, but this necessarily gives them an intermittent jerky motion which is not good. It cannot, perhaps, be said to do any harm, but the regular motion of a belt is always better, provided that the belt does not slip on account of its slow speed. Nothing need be said regarding the strippers. Their function is simple—to carry the wool from the worker back to the swift, and they must be set sufficiently near each other to do this properly. All the rollers of the card need cleaning from time to time, according to the sort of wool being carded. On an average twice a week is enough, but if the wool is dirty, oftener may be needed, though the remedy for that is to see that the wool is properly washed. Two instruments may be used for cleaning, either a doffing knife with about 18 teeth per inch for a medium card, or a hand card, which is a

piece of old card cloth stretched on a wooden frame. If the wires of this are still a good length, this is the safer instrument to use. The chief point to be attended to is that the comb or hand card is drawn straight over the wires, so that they are not bent in a slanting direction.

167. **Grinding.** — More important even than the cleaning of the cards is their grinding. When any roller is newly covered, the ends of the wires (except for

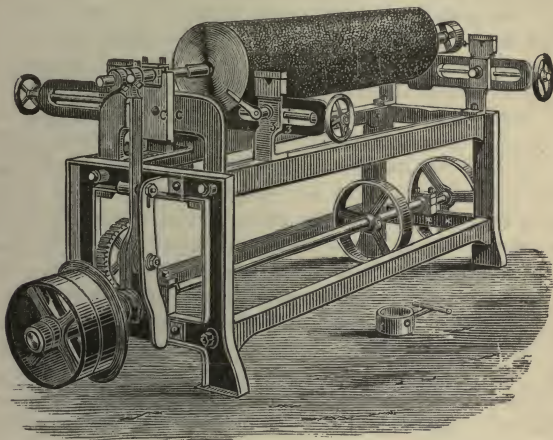

Fig. 59.

needle and diamond point) are square and rough, just as they have come off the card-making machine. They must be ground to a point before they can be used. The grinding frame (Fig. 59) consists of a stand with a roller of 8 to 12 inches diameter or even more, running in it at a great speed. The roller is covered with emery powder glued on, and is made with great care to ensure that there are no lumps projecting beyond the rest which could over-grind and damage the card rollers. Generally these rollers are sent to the makers to re-cover as they are

worn out, because of the care needed to make them perfect. The rollers of the card, fancy, workers, and strippers are brought to the grinding frame, and placed in stands, one on each side of the emery roller, and the three are then set in motion, running in such a way that the emery roller grinds against the smooth side of the wires. The roller traverses about 2 inches, to prevent it always grinding in stripes in the same place. For swifts and doffers, the emery roller is taken to the card, and the grinding takes place there. A great deal of harm can be done by over-grinding. The fancy only needs it once, and thereafter keeps itself sharp. Regarding the other rollers there is much dispute. The case of those who argue against grinding after the first sharpening of the cards may thus be summed up. It is better to have the card points *smooth* than *sharp*. When they have once been ground sharp, and set properly, they work themselves smooth with needle points. As the swift keeps the fancy smooth, so the fancy must keep the swift, and hence the latter will not need grinding. The doffer can be kept both sharp and smooth by the roller which runs on it as above-mentioned, and will be hurt by grinding. The workers can be kept sharp by letting the strippers rub slightly against them; and though the strippers may thus lose their points, it does not matter, as they will become very smooth and equally useful. Instead of grinding, a piece of emery cloth stretched on a wooden frame is held by the carder to the rollers once a week or so to throw out dust and dirt from among the teeth, and this also gives any little polish that may be needed to the points. There is no doubt that when this method can be carried out it is far preferable to grinding, and there seems no reason why, with good wool, it should not be the rule instead of the exception. That it is an immense saving both of time and card wire is clear, for cards are worn away much more by grinding than by natural wear. Those who favour grinding (and once in three months is not an unusual time for the operation) contend that the

points get too blunt, even though they may be smooth, and that they hold and comb the wool better when newly sharpened. Both will agree, however, that there should be as little grinding as possible, and that if the process is carried on too long, and the point thus made too thin and fine, it curls over downwards, and forms a hook which catches the wool, and the roller can hardly be made right again. If the roller is covered with coarse emery, the wires are ground at the sides as well as the back, for the grains run between the points of the wires, and not merely over them. If the emery be too fine, it cannot do so, and merely runs over the top or back which causes the wires to be ground into something like diamond point rather than needle point, which latter is the thing desired. Some grinders hold it to be a good thing in the first grinding to run the emery roller the reverse way, *i.e.*, to grind against the points of the teeth in order to make sure that they are all reduced to one level before beginning to grind the point on the right way. It certainly is necessary to have all the wires on one level, but the perfection of card-making almost ensures this now, and the risk of face grinding is great. Where the card is uneven it can, however, be done with advantage if done very gently.

168. **Turning and Covering Rollers.**—Card rollers are now often made of iron, which possesses the great advantage of always being true and never warping. They are, of course, much heavier. With wooden rollers, whenever they require to be re-covered, they have to be turned to make sure that they are level. The process of turning or trueing them is simple. An iron rod, perfectly level, is screwed to each side of the bend in which the roller runs, at an equal distance all the way from the roller. The turner then fixes his knife at the right length, sets the card roller in motion, and as it revolves against his knife any parts which are untrue are shaved off. The card sheets or fillet can now be nailed on. Various mechanical contrivances are used for

stretching them to ensure tightness and uniformity of tension, and any one will do which gives this. For filleting, the best method is to pass the fillet over and round a roller to give it a good deal of friction, and then to wind the card roller slowly till the fillet is wrapped round it, when it is fastened down with tacks.

169. **Card Clothing.**—We have now only to add a few words regarding the card clothing itself. It consists of wires stuck into leather or cloth of some kind, which is called the foundation. Leather is undoubtedly the strongest and firmest foundation for swifts and doffers, but has three drawbacks. Being very firm, all the strain is borne by the wire, and none by the leather; the holes in the leather for the teeth have to be made rather larger than the wire, and thus leave the wire loose; and thirdly, it is very dear. It is not spoilt with oil, however, which is an advantage for woollen carding. For worsted carding vulcanite cloth is used, which is more pliable and relieves the wires, and also holds the teeth better, the holes being made a trifle smaller than the wires. It is made of cotton and linen cloth cemented with vulcanite india-rubber. For cotton carding this is always used, and the only reason it cannot well be employed for woollen is that the oil spoils it. The small quantity of oil used for worsted carding seems to have no effect on it, nor is it hurt if the wool is damp. The wires are, however, injured by damp, but a patent has been taken out for tinning the wire so that it cannot rust, and this is found to be a very great improvement. During the last few years iron card wire has nearly gone out of use, and steel is everywhere preferred. It costs more, but retains its point better and is much more durable, doing better work. No suggestion would be of use here regarding the size of wire and the “counts” and “crowns” used, because these must depend on the class of wool carded. It is, however, a perfectly safe rule to prefer finely-covered cards to coarse ones. No harm is done to the wool by fine cards, and as the

coarsest wool is so much finer than the finest wire it is possible to use, it is a mistake to lose carding surface by reducing the number of points and increasing their size. For lickers-in, opening rollers, breasts, etc., the wire must, of course, be strong. Still we do not advocate carding coarse wool on a Botany card, but merely point out that it is better to lean to fine setting rather than to coarse. Wire is drawn to numbers from one upwards, according to a regularly graduated scale, but cards are not ordered by the number of the wire but by counts and crowns. The standard width of a card sheet in England is 5 inches, and the count of the sheet is the number of wires in a straight line *across* it. The crown, on the other hand, is the number of wires in 1 inch *along* it. But every wire along the sheet is equal to two points, because the wire is bent to form three sides of a square, the centre part being at the back of the sheet, and the two sides piercing it, and standing up as the card wires. These always run lengthways of the sheet, so that supposing there are ten per inch at the back they really give twenty points on the face of the card. This would be 10's crown. If there were 100 wires across the 5-inch sheet, this would be 100's count. The count and the crown usually correspond in this way, and are written  $100 \times 10$ ,  $120 \times 12$ , and so on, unless otherwise ordered. Now as the 10's crown represents 20 points per inch, and the 100's count 100 points per 5 inches, it follows that there are 20 points of wire each way, or 400 per square inch. This scale is used for all card clothing; and even in the case of filleting, it is reckoned on the basis of 5 inches in width, though it is usually  $1\frac{1}{4}$  or  $1\frac{1}{2}$  inch only. All card wires are bent at a third or half way up, to give them the necessary spring and elasticity. This is called the "bend" or "knee," and it depends on the temper of the wire how efficient the cards are. When by grinding or other causes the wire is worn down to near the bend, the card is quite done, and indeed it should be replaced before it has got to that state. Very short and worn clothing

makes more card waste, and within a brief period the loss in card waste and bad work will be as great as the cost of new clothing. The wires must all be kept well up and in their proper places, or the work done will be bad. Being tender and easily bent, they will get pressed flat or sideways if care is not taken in the stripping and grinding. In woollen carding, in order to preserve the wires and make them rather firmer, the cards are filled up with a composition of flocks and oil as high as the bend of the wires. This becomes quite firm in time and helps the wires to resist the strain of the wool. It also keeps the wires oiled and therefore free from rust. In woollen carding the wool, shoddy, etc., are usually carded damp as well as very oily, to prevent them from making too much fly. This damp would otherwise rust the wires and cause them to break at the bottom. In worsted carding, the wool is not so damp, and tinned wires are often used. Where vulcanite is the foundation of the cards this stuffing is impossible, as the oil would spoil it. When card-rollers are covered with filleting, the covering is continuous, because one strip is wrapped round and round the roller. But when they are covered with sheets, there must be a gap of about a third of an inch between the wires on one sheet and those on the next, to leave room for the edges by which it is nailed. We shall see later on one drawback of this in the last swift.

**170. To find the Amount of Clothing Required.**—To obtain the number of running feet of filleting needed to cover any roller, multiply the length of the roller by its circumference, and divide by the width of the fillet. It is best to reduce all these to inches, as filleting is  $1\frac{1}{4}$ ,  $1\frac{1}{2}$ , or 2 inches wide. To find the number of square feet on a swift or other roller, multiply the length by the circumference and divide by 144 (the square inches per foot) and the answer will be given. To find the number of sheets 5 inches wide for a swift, divide the circumference by  $5\frac{1}{3}$  or  $5\frac{1}{2}$ , *i.e.*, allowing for the space for nailing between every sheet.



## CHAPTER X.

## FEEDING, CONDENSING, AND SPINNING.

171. **Intermediate Feeding Machines.**—In the last chapter we explained the principle of Bramwell's and Evan and King's card-feeders, for supplying the first card or scribbler with wool. We must now consider the best methods for supplying the second card and condenser. It must be remembered that woollen carding has to take the place of preparing, combing, and drawing in the worsted trade, and therefore it is not only necessary to card the wool properly to open out and mix the fibres, but also to reduce them to level rovings for spinning. If the wool from the first scribbler were taken by hand and fed into the second scribbler, or even fed by Bramwell's feed, no levelling could be done, for the levelness gained in the first machine would all be lost. It is necessary, therefore, to employ some other machine which will feed regularly, preserve the level end from the first scribbler, and facilitate as many doublings as possible, to make the result from the second machine still more level.

172. **Blamire's Feed.**—There are four intermediate feeding machines commonly used, each of which has its own merits. The oldest is the Blamire feed, of which a drawing is given (Fig. 60), as made by John Tatham, of Rochdale, a well-known woollen and cotton machine maker. The last doffer of the first scribbler is shown. The wool is taken from it by a roller which combs it off, and passes it on to an endless lattice, marked "upper lattice." This travels forwards, bearing over its whole surface the film of carded wool. When the wool arrives at the end, it is passed down by other rollers on to a lower lattice, the same length as the width of the upper one, which travels

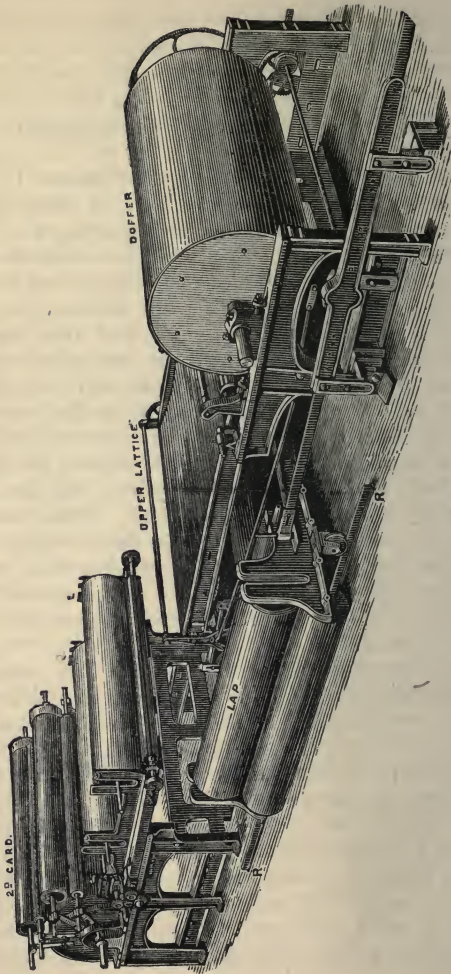

Fig. 60.

backwards and forwards along the rail, R R, and by this means the lap is evenly spread in layers all over it, being folded at each edge as the lower lattice comes to either end of its journey and begins again. But while the upper lattice travels forwards, the lower one, relatively to it, travels sideways towards the lap-roller, moving very slowly, but continuously, and so carrying the accumulated layers of carded wool to be automatically wound on to the lap roller. The lap may be made any thickness, according to the speed at which the lower lattice travels, and every fold makes one more doubling to level the wool. When the lap is large enough, it is taken off by the card minder, and an empty roller put on to be filled. Two lap-rollers are placed to feed the second card, as shown at L L, and it is usual to time them so that one is full when the other is half empty, so that two joints never come together. A common number of layers in a lap is 30 or 40 for heavy woollens, so that by placing two of these to feed the second card, from 60 to 80 doublings are obtained. This is the best feed motion for heavy woollens which contain much short wool or shoddy, etc., because there is no tension on the material, and it has not to support its own weight at any place. It also makes a good solid lap, very suitable for feeding a card. In common with all other feed-motions except one, the fibres are delivered into the card in a direction at right angles to that in which they came out of the previous one, because the lower lattice travels across the upper one. For long wool this is a drawback which all share in common, but for short wool it is of no consequence, as the fibres are lying in every direction. The chief drawback of Blamire's feed is the amount of room it requires; for besides the length of the upper lattice, the lower one must travel out a distance equal to the width of the rollers it has to feed. There is a form of this machine, however, known as Ferrabee's, which takes less room. In it the lower lattice does not travel on the rail, R R, but remains close to the doffer. The

upper lattice is made double, like a pair of tongs, with the low end of one tong fixed at the doffing-roller. The wool travels up one leg, so to speak, and down the other, and this latter leg moves backwards and forwards over the lower lattice, spreading the wool on it. By this way the wool has farther to travel, but space on the whole is saved. The other motion is, in spite of this, preferred.

173. **Balling Head and Creel Feed.**—The balling head and creel motion ranks along with Blamire's as the best. A drawing of the machine, also Tatham's make, is here given (Fig. 61), which shows the working at once. The sliver before going into the baller can be drawn off the doffer in two ways. If it is combed by the doffing-comb and gathered up *in the middle*, passing through a revolving funnel to give it enough twist to make it hang together, then the fibres retain the position in which they left the doffer, and are fed from the balls *lengthways* into the next card. For longish wools this is the best way, because it helps to preserve the length of the fibre, but it is only done at a sacrifice of the number of doublings. For if the wool is taken from the doffer by *side drawing*, —*i.e.*, taken from it at one side and rolled into a loose rope as it is drawn across the face of the doffer to the other side, then by the mere fact of its passage across the face of the doffer it receives a number of doublings. Supposing certain fibres, A, drawn off the right-hand side of a 40-inch doffer, take 10 seconds to reach the rollers shown at the left-hand side and are rolled over ten times in the passage across, and suppose the doffer revolves three times a minute, or half its circumference every 10 seconds, then it is clear that when the fibres, A, which left the right-hand side, reach the left-hand side, they will be joined by fibres, Z, which were exactly at the other side of the doffer, when fibres, A, were taken off, and the group of fibres which make up the rope with A and Z are those which were lying on the doffer in a line drawn diagonally half round it from A to Z. When

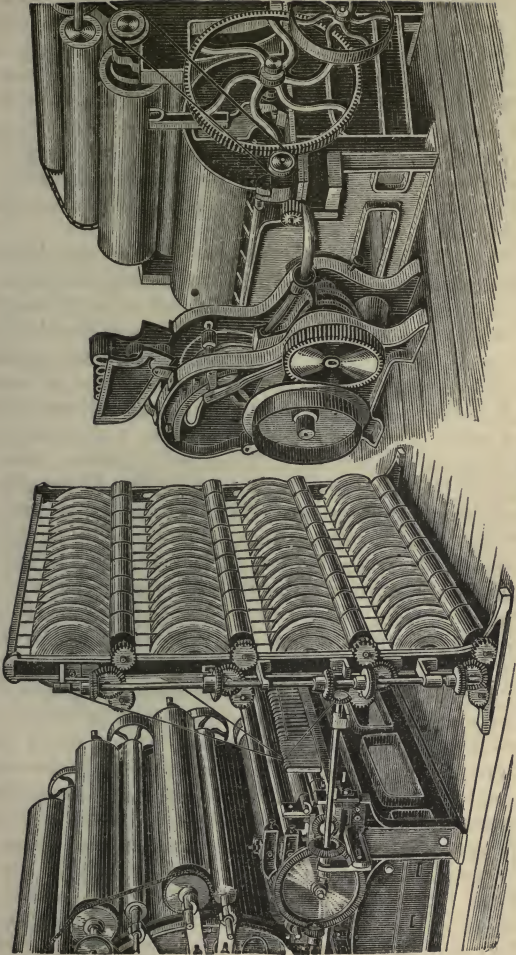

Fig. 61.

we consider the number of revolutions which the swift has made to cover half the surface of the doffer, we can see that the side-drawing method secures a very large amount of doubling, which is lost by drawing from the centre; and it is for the carder to decide whether he will have the extra doubling with increase of levelness, or keep his fibres lengthways. For all very short wool there can be no doubt the former is best. The figures here given are merely chosen for clearness of illustration.

The slivers, however drawn off, are automatically wound on to wooden rollers in the balling machine, and by an ingenious motion, when the ball is large enough, it is thrown out and another bobbin drops down to take its place. These balls, or cheeses, as they are generally called, are set in a rack, and their ends fed in to the next card as shown, and are wound off by the rollers on which they rest. There are 64 cheeses put up at once, and therefore 64 doublings if the sliver is drawn from the centre. If from the side, with 10 turns in the passage, then the doublings are 640, which is a startling difference, and a greater amount of doubling is obtained by this means than by any other possible. It has two weak points: it is not continuous, for the balls have to be renewed from time to time; and it takes nearly a day to make a complete set of full balls. Hence the second card must be a day behind the first in its work; the first one will run out a day before the second, and all the waste made during that day cannot be used again in the same blend. For small lots, too, which fancy manufacturers have in great abundance, this machine cannot be used at all, as one lot might not make more than a quarter of the number of balls needed, and it is important to work up all the waste at the time. For large lots, and for an *intermediate* card, it is the best system. It should not be used for a condenser card, because as the slivers are put endways into the feed-rollers, and as they come out in rovings off the condenser,

each one or two ends would go straight through the card, and the benefit of the 64 being together would be lost. For a condenser there is probably nothing to beat the Blamire laps.

174. The Scotch Feed.—The Scotch feed (Fig. 62)

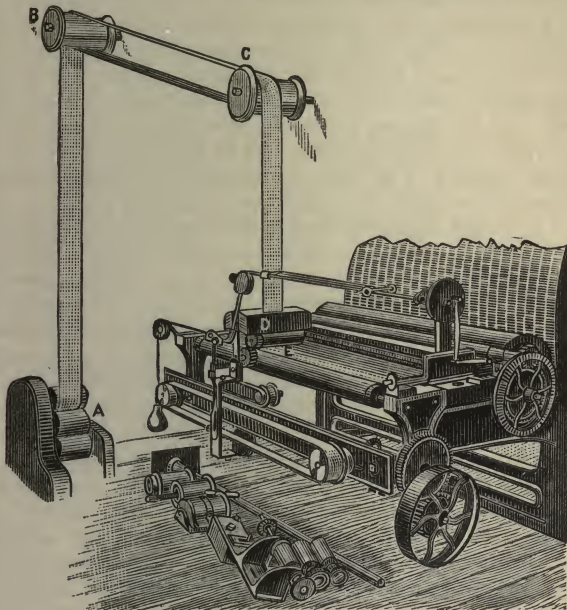

Fig. 62.

is, however, preferred by some. The doffer is not shown, but the wool is laid from it on to a lattice travelling across the width of the card, and is drawn off in a flat sliver by the rollers, A. This is carried up to the rollers, B C, which are always revolving, and down again to D. The rollers, D, travel across the feed lattice, E, and deposit the sliver in layers on it. The lattice, E, travels at such

a speed that one layer of sliver just overlaps half the layer which has gone before it, and is thus made two-fold. This is a side-drawing system, and, on our former supposition of speeds, would have the same number of doublings per sliver as in the baller, but only two slivers go together into the card instead of sixty-four, though, being laid sideways, they represent a longer time in drawing from the doffer. In this motion the sliver is not twisted at all; it is a ribbon, not a rope. Its great advantage is that it is continuous, and that the second card can be started a few minutes after the first one, and all the waste therefore can be used up. For heavy loose material it is not very suitable, the drag on the fibres as it rises to the rollers, B C, being too great.

175. **The Apperley Feed.**—For low material the Apperley feed is the best continuous motion, and, indeed, it is very largely used for all classes of work. The sliver is drawn off by side-drawing, and twisted in the process, like the side-drawing of the balling method. It then falls down naturally in coils on to a travelling strap near the ground, which conveys it to the second card. There it rises up and is taken by a pair of rollers and laid diagonally across the feed lattice. In the Scotch feed the wool is laid on the lattice nearly straight, being only diagonal to the extent of the distance which the lattice travels as the rollers go across. But here it is as diagonal as possible, the rollers travelling from the corner of the lattice farthest from the feed rollers to the diagonally opposite corner nearest them. This is in effect the same as feeding by the ball system, only that instead of sixty-four balls, it can only have about twenty ropes going in at once, and therefore the doublings cannot be so numerous. It is suitable for the intermediate card rather than the condenser for the same reasons which apply to the ball machine, but it has the advantage of being continuous, and enabling the second card to run along with the first. Continuous feeding is, however, not the unmixed benefit which might be supposed. With this system, small lots



can be best worked, and when both cards are running it is very good. But the moment one machine stops for any cause, the other must stop too; now cards have to be stripped and cleaned, and with the Blamire and balling systems one card can run while the other is standing, and therefore in them a great saving of time is effected. This is such an important matter that it seems to turn the scale in favour of these methods of feeding, and therefore we would say that for large lots and the intermediate card the baller is best, while for the condenser, and for small lots, Blamire's carries off the palm.

176. **Last Swift to be Covered with Filleting.**—We may here draw attention to a point which is overlooked by nearly all carders, but which is of some importance considering the necessity for having the roving, which comes off the condenser, perfectly uniform and free from weak places. It is usual to cover the doffer of the scribbler and of the intermediate card with sheets which, as we have noted, involves leaving spaces of say one-third of an inch between each sheet. If these doffers feed on to a Blamire lap, it will be seen that when the film of wool is on the top lattice, it represents exactly the surface of the doffer; *i.e.*, at every five inches of film there is a thin place, or a break altogether. As these are laid layer on layer and then fed in the transverse way, it does not matter much, though it seems as if it would be better to cover the last doffers always with filleting as is done in worsted cards. But when we come to the condenser it is more important. The ring doffer is, of course, always covered with continuous rings without any break, but the swift which supplies the doffer—and this is the point requiring attention—is nearly always, like all other swifts, covered with sheets. Now we have seen by looking at the Blamire upper lattice that wherever the space between two sheets comes, at that point there is a break in the film. But as the Blamire lattice is to the scribbler's doffer, so the ring doffer is to the last swift, and as on the former there are breaks in the film of wool

laid on to it, so on the latter there must also be breaks in the film. They are invisible no doubt, because the swift goes so quickly that it crowds on to an inch of the doffer's surface what has spread over several feet of its own surface, but the breaking of the film is there all the same, and may or may not be mended by the rapid passage of the swift. The point is, perhaps, a small one, but when the roving is stretched out on the mule every little weakness is felt, and whatever tends to prevent it from being perfectly uniform is distinctly bad. By covering the last swift with filleting, very carefully stretched and nailed on, this risk will be avoided, the roving will certainly gain something in strength, and the spinning be by that much improved.

177. **Ring doffers.**—We have now finally to consider the last doffer and the condenser before coming to the spinning. The English method is to cover the last doffer with rings instead of continuous filleting. These rings are simply circles of filleting, just large enough to be put on the doffer at one end and then pushed down it to the other, and so on till the whole roller is covered with these rings. Though this is the main feature of the ring doffer, it is divided into several varieties. (1) The double rubber condenser; (2) the single rubber condenser, both of these being worked with single ring doffers; (3) the double ring doffer. For the first two there is just one doffer; it is covered with rings  $\frac{1\frac{3}{8}}$ -inch wide, and between each ring the space is filled with strips of leather or vulcanite  $\frac{3}{16}$  of an inch wide, as high as the top of the wires on the rings. It is difficult to get the rings all of quite uniform leather, and all equally tight, and to meet this some persons now cover with filleting, which is wrapped on very carefully, and then enough wires are cut away close to the foundation to make the spaces above referred to, and these are filled with leather, etc., in the usual way. This doffer then works against the last swift, clearing  $\frac{1\frac{3}{8}}$  of every inch of it. To prevent the  $\frac{3}{16}$ , which are left forming into ridges, two of the workers on the

swift have a traverse motion, so that they catch and spread over again the fibres left by the doffer. This is a wasteful way, in so much as the carded wool thus left, although ready to be doffed, has to be sent back to the

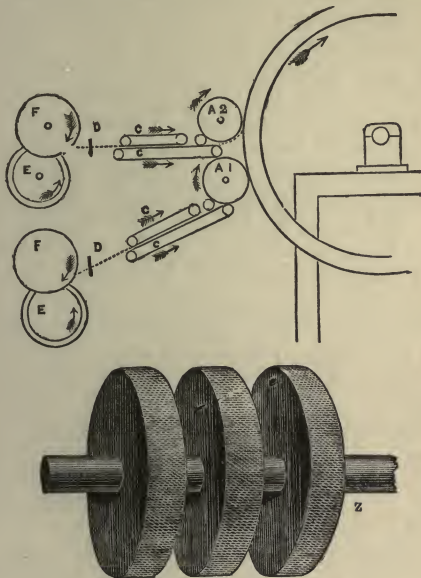

Fig. 63.

swift to be again worked and placed on the doffer at the next opportunity.

178. **Double Rubber Condenser.**—The double rubber condenser works against the single doffer as here shown (Fig. 63):  $A^1$  and  $A^2$  are the rubbers, of which a perspective view is given at  $z$ . The lower one clears every alternate ring of the doffer, and the upper one clears the others, each rubber taking an alternate ring. They revolve in the direction marked by the arrows, and as the wool comes

off with them, it is passed between the rubbing leathers, c c. These have a double motion. They are endless leathers travelling as marked, so that they carry forward the thin ribbon of wool which is between them, and they also have a side motion which makes the one rub against the other, and condense the ribbon of wool into a round pith-like roving without any twist in it. This is the portion of the machine which makes it possible to spin direct from the card, for if the roving were not rubbed strongly and quickly together, it could have no consistency, and would remain a mass of loose fibres, quite useless for the purpose. It is this same rubbing leather motion which plays a leading part in French worsted drawing. On leaving the leathers, the end passes through a guide, D, round a roller, E, and on to the bobbin, F, when it is ready for spinning. This system is used for coarse wool which has many fibres standing out, because it is necessary to separate the rovings thoroughly, and not leave stray hairs to catch from one roving to another. Its drawback is that it is difficult to get each rubber set exactly alike on the rings of the doffer. If the lower one is nearer, it will get more wool, leaving the upper one rather bare, and in any case the lower one, which clears the doffer first, has a tendency to catch the long hairs, and so take more than its proper share, and thus be rather heavier and make thicker yarn.

179. **Single Rubber Condenser.**—The single rubber condenser (Fig. 64) avoids this, but still it is not so well suited for long wool, because the stray hairs catch each other in the rubbing leathers, and break the rovings. For it the ring doffer is the same as before. The rubber, A<sup>1</sup>, is a roller with bosses on as in the former case, but there is only one instead of two, and it clears every ring of the doffer at once. The small ribbons of wool which it strips off are passed under the grooved roller B, the ridges of which (see B<sup>1</sup>) separate effectually the different ends of the condensed wool. All the ends then pass through the leather rubbers as before, and on to the bobbin. As

these roving ends are only an inch apart, it will easily be seen that only short fine wool should be worked in this

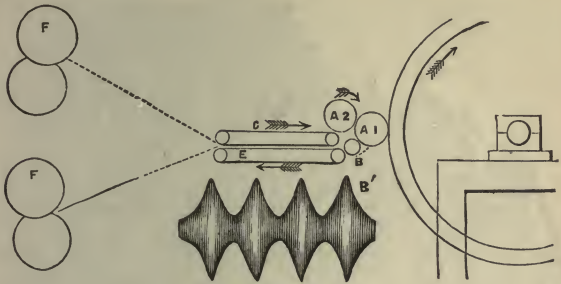

Fig. 64.

way ; but given this material, it is the best method, as the roving must all be one weight.

180. **Double Doffer.**—The third method is the double doffer double rubber condenser, made by Tatham, of Rochdale, of which a full drawing is given (Fig. 65). The body of the card is the same as usual ; but instead of one large front doffer to clear the swift, there are two small ones, about fourteen inches in diameter, covered with rings an inch wide, with an inch space left blank between them. The doffers are so placed that the ring of the one is above the blank space of the other, so that they entirely cover the surface of the swift, and take all the wool off it, which is an improvement on the single doffer, where some wool is always left. The drawback of this system is that it is always impossible to get the roving from each doffer alike, that from the upper one being the heavier because the swift meets it first. There are always some loose hairs thrown off by the fancy, which fall on the swift. These the top doffer gets, and it will also probably get some of the projecting hairs which belong to the part that has to be stripped by the bottom doffer. This will be seen from the positions

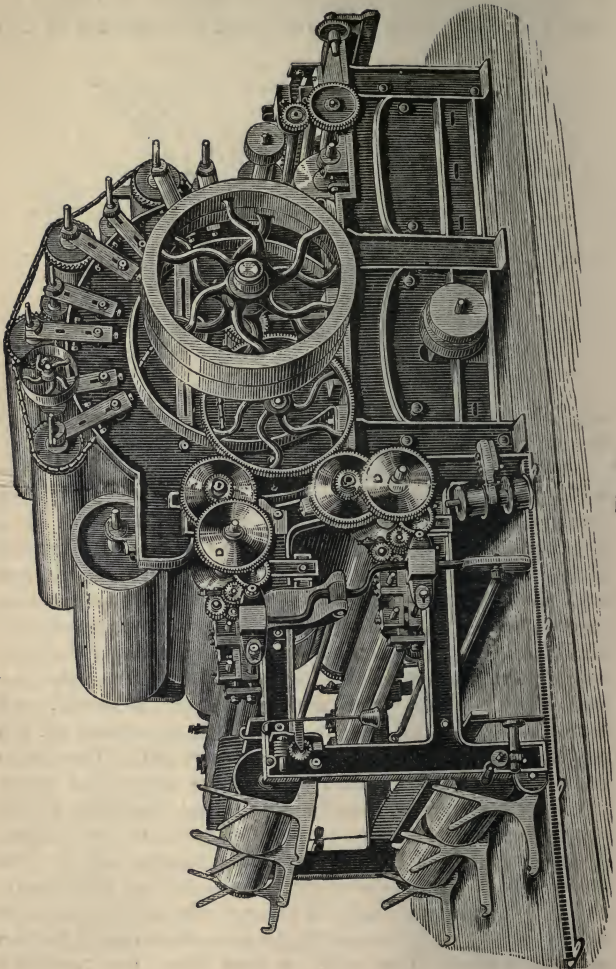

Fig. 65.

of the two doffers, marked D D. They are driven by toothed wheels from the cylinder shaft, and their speed can be altered by changing the wheels which drive them. If the yarn is to be kept regular, the top rovings should always be spun separately from the bottom ones; but the thickness can be regulated to make them nearly alike by altering the speed of either. There is no other way of affecting the difference satisfactorily, as each should be set as close as possible to the swift without touching it. From the doffers, the ends are taken in the regular way to the rubbing leathers, and on to the bobbins. This method is used for very coarse wool, where even the double rubber does not separate the fibres sufficiently. It is also used where two thicknesses of roving are wanted from one blend; by altering the driving wheels, the speeds can be changed to any extent.

181. **Belgian Condenser.**—The Belgian system, invented by Celestine Marten, differs from all these. There is no ring doffer. The doffer is covered with filleting, in the same way as any other fillet-covered doffer, and the film of wool is taken off in one broad sheet. This sheet has to be divided or condensed into rovings. It first passes between two iron rollers, made with alternate solid rings and grooves, somewhat like the one shown above, but not cut so deep. They are in appearance like two small ring doffers placed on each other, the ring of the one against the groove of the other. In each groove is a leather strap, which just fills it up, so that when the rollers are together there is a series of leather straps continuously all along them. Each leather strap, groove, and ring, represents one end of roving to be made. As the film of wool passes through these rollers it is divided into ribbons, and is so twisted by the leather straps that what was in a groove is now carried down to a solid ring, and what was in a solid ring is carried up into a groove of another pair of rollers in front. Owing to this crossing backwards and

forwards, the condensed ends are thoroughly separated, and can then be passed through the rubbing leathers and on to the bobbin. This method is said to be much superior to the English one, and has been further improved by J. S. Bolette, of Pepinster, in Belgium, who, instead of rollers, after the first pair, employs twisted endless leather straps that divide the rovings, and pass them on to the rubbers. A better spin is obtained from this method, but it does not appear yet to have made much progress in this country.

182. **Belgian Carding.**—As we have given this brief account of Belgian condensing, it may be well to state the system of carding they have adopted, as it is totally different from what is seen here. As is well known, the Belgians have entirely beaten the English woollen spinners in one, if not more, branches of the trade, the one here referred to being in fine all-wool yarns chiefly for the Glasgow market. It is not a question of hours and wages, but of power to produce the yarn. They use Buenos Ayres wool chiefly for it. The following extract, describing the Belgian cards, is from a letter by Mr. T. Lister, of Huddersfield, addressed to the *Textile Manufacturer* :—

“In the continental system we will take as our example the machinery of M. Marten, a large Belgian maker, machinery admirably adapted in every respect for the production of the yarns under our notice. This set consists of three separate single cylinder engines, 10 inches wide; the breaker comprising 1 licker-in, 50 inches diameter, with burr roller, 1 small breast, 10 inches diameter, with 2 workers and 2 strippers, each 3 inches diameter, all of which are covered with garnet saw-tooth licker-in wire; 1 cylinder, 44 inches diameter, 8 workers, 7 inches diameter, 8 strippers, 2 $\frac{1}{4}$  inches diameter, 1 angle stripper, 6 inches diameter, 1 fancy, 15 inches diameter, and 1 doffer, 16 inches diameter, stripped with a fly comb; the intermediate and condenser carder are of the same dimensions as the



breaker, without the breast, all clothed with the stiff Belgian cards. The condensing machine is M. Marten's strap patent, which dispenses with our usual doffer covering of separate rings, or ribbons, thus saving so much of what to us is wasted space, and enabling it, by utilising the whole of the doffer surface, to turn off the large number of 120 good threads from this narrow width of 50 inches. This machine, condensing to 20 skeins, and saving the intermediate process of roving, is capable of turning out 110 pounds per day of ten hours. Compare, or ought I not to say contrast, this set with our usual bulky carding machinery, 60 inches wide, containing 4 cylinders and 4 doffers, each one of which is larger than a Belgian one, with the addition of a breast large enough to entitle it to the name of a cylinder. Let any one take the separate dimensions of the two sets, and he will find that the Belgian set requires fully one-third less card covering, and one-fourth less motive power."

The difference is striking enough to need no comment, but to make it desirable that the facts should be known.

183. **Mule Spinning.**—We come now to the final operation of spinning on the mule, and shall see how entirely different it is from even the mule form of worsted spinning. It is not necessary to give a complete description of the various parts of the mule. The aim of this book is to describe processes and machines just so far as to enable those who work them to have a thorough knowledge of how they should be worked, and therefore we do not need to describe at length motions which never alter, and which are fixed by the machine maker. It is enough to indicate their general functions. Any full account of the mule would occupy too much space, for it is one of the most intricate and complicated of machines. The drawing here given (Fig. 66) of one of Tatham's woollen mules—which are very different from cotton mules—will give a general idea of the machine. The long rolls of condensed roving from the card are set

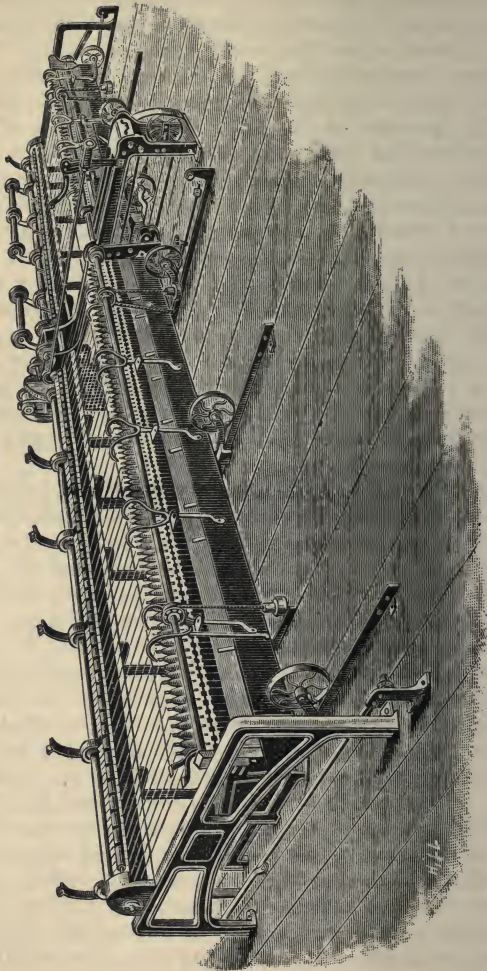

Fig. 66.

on the upright stands at the back, which are here shown empty. As they unwind the ends pass through the rollers. There is only one pair of rollers for woollen spinning, and they correspond to the *back rollers* of a throstle spinning frame, and not to the front ones, for they do not draft the roving. The ends are fastened round the spindles to the little paper tubes, on to which the yarn is usually spun for warp, or on to the spools, which are used for weft. The carriage in which the spindles are placed, and in which they run, being driven by bands concealed in the lower part of the framework, is at the commencement close up to the rollers. As soon as the rollers begin to revolve, delivering the roving, the carriage also starts, and travels on the rails, as shown, away from the rollers, at such a speed as to keep the roving nicely stretched, but without drafting it. The spindles also begin to turn comparatively slowly, putting a little twist for the first time into the roving. When the carriage has gone about half its journey, *i.e.*, about a yard, the rollers cease to deliver any more roving, but the carriage proceeds, nevertheless, to the end. The draft is now being put into the yarn, for the one yard which was delivered by the rollers is drawn out to two, and it is being twisted during exactly the same time that it is being drawn, and by the same means, namely, the spindle, as that which draws it. When the carriage stops the yarn is spun, but if it is necessary to put more twist in it, which is usually the case, the spindles continue to revolve, and at a greatly increased rate, to save time. This extra twist shortens the yarn, and therefore the carriage has to return slowly a few inches, the length being proportionate to the time the spindles continue to put in twist; but care is taken that the yarn is always kept at its full tension. There is no flyer on the spindle, but the yarn is raised up to above the level of the spindle top, and afterwards lowered again by two wires running the length of the mule, called the *faller* and *counter-faller*. But for this the

spindle in revolving would wrap the yarn round itself; but as it is raised the yarn at every turn slides over the spindle top, and so receives twist without being wrapped on. When the twisting has ceased, there are a few inches of yarn always wrapped too high on the spindle, and these must be unwound and then rewound along with the two yards of new yarn just made. The spindles reverse themselves a few turns, the faller and counter-faller change positions, being lowered to keep this unwound yarn straight, and then the carriage begins to travel back to the rollers, and the spindles wind on the yarn in its proper place on the spool, the position of the counter-faller determining on what part of the spool it shall be wound. In doing this it takes the place of the lifter motion of the throstle frame. All these many and complicated motions are worked automatically, the spinner having nothing to do with them. It is for this reason these mules are called self-actors, to distinguish them from the hand mule, whose different motions were regulated and worked by the spinner. There is not much alteration in the draft. The usual course is for the rollers to deliver during half the journey of the carriage, which gives a draft of two; but for thick yarns this is often reduced to a draft of one and a-half—*i.e.*, the rollers deliver during two-thirds of the journey of the carriage. The draft can be altered in the simplest way, that is, by altering the length of time during which the rollers deliver the roving. This is done by moving what is called the “setting finger,” in a groove on the face of the “slubbing wheel,” to the figure required, which is indicated on its face. The position of this finger determines the number of inches turned out by the rollers. There are, therefore, no change wheels, and no reckonings-up to find the draft. A similar contrivance, by altering a peg in a wheel, determines the twist which shall be put in after the carriage has stopped; and thus, though the machine is really much more complicated in its construction than a throstle, it is very

much simpler to work, and no calculations are needed by the minder or overlooker. The rovings are made thick or small by the speed of the ring doffer, and by the amount fed into the scribbler and card, according as the yarn to be spun is coarse or fine in counts; and, as above shown, the size of the yarn can be again altered by regulating the length turned out by the rollers.

184. **Difference between Worsted and Woollen.**—So much for the actual operation of spinning. It is worth while now to consider again the difference between a worsted and woollen yarn, by noting the action of the fibres as each is being made. We have seen the difference in the preparation for each. In every sort of preparation for worsted yarn, including the French system previous to the worsted mules, the sliver, slubbing, or finishing, as the case may be, is drawn out from one end, and as fast as that end is drawn, more is supplied, and the fibres are kept smoothed straight out. In the rovings made on the condenser there is no attempt at drawing out either at one end or anywhere else. The fibres in the rovings are just in the same condition as when they left the ring doffer, except that they are rubbed by the condenser leathers, to make them hold together. So too with the spinning. In worsted, in every kind of spinning machine, the drafting is entirely separate and independent of the twisting, and either can go on, so far as the machine is concerned, without the other. That is, the rollers can deliver the yarn though the spindles may be standing (in which case it becomes soft-waste), or the spindles can revolve though the rollers are standing (when the part thus hard twisted becomes hard waste). The front rollers which draft the yarn, draw it out inch by inch from the end of the roving which is being continually supplied by the back rollers, and only those fibres are being drawn out which are in the nip of the front rollers at any given moment. The fibres which have not yet reached, or have entirely passed through these rollers, are not being interfered with by them. As

fast as the fibres pass through the front rollers, they are twisted and in throstle frames are wound on to bobbins. In the worsted mule they are wound on after the twist and drawing have ceased. Thus in all these frames there are three distinct operations carried on successively but simultaneously (except in the winding on the mule); these are drafting, twisting, and winding on to the bobbin; and only the fibres which are passing through the front rollers are being drafted at any given moment. With the woollen mule all this is different. Part of the twisting is done before any draft is applied, part while the drafting is going on, and the rest after it has ceased. The winding-on is done after both drafting and twisting have ceased. But in the drafting itself we see the main difference. A whole yard is drafted at one time into two yards. The instant the rollers cease delivering, every fibre in the roving begins to move both with a rotatory and longitudinal motion, the result of the combined twist and draft. As the yarn depends for its strength on the longest fibres, these form themselves into the core, and gather as they twist the other fibres round them. If there be a thin place in the roving it is drawn out thinner, and then the twist runs up to it, for twist will always run to the thinnest point in a thread or rope. By this natural means, the thin place is hardened and resists any further drawing, while some thick place which is short of twist gets pulled out, and so the whole length is equalised. Thus the operation is completed. The long fibres tend to go to the centre and gather the others round them; they all lie in whatever direction they happen to have left the condenser, subject to such alteration as the draft may have caused; but there is no attempt to make them smooth and parallel, as is the case in the worsted thread. The method of the drafting taking place throughout the entire length of the delivered roving at the same moment, precludes the possibility of this happening. We thus see that the definitions we

previously gave were correct, viz., that worsted is a thread spun from wool, in which the fibres are so arranged as to lie smoothly in the direction of the thread and parallel to each other; and that woollen, on the other hand, is a thread in which the fibres are arranged so as to lie in every direction, and to cross and overlap each other that they may present their serrated surfaces in the greatest variety of ways.

---

## CHAPTER XI.

### TWISTING, REELING, AND SCOURING.

185. **Winding.**—We have followed the course of the wool through its various processes which were common to both worsted and woollen, and also through the more numerous and complicated ones which each division has for itself. The two may now be again united so far as the purpose of this book is concerned, though the special methods in each trade may somewhat vary. Want of space, however, precludes any lengthy description of the processes of twisting, reeling, and scouring; and dyeing is not within our present scope.

It is a disputed point whether yarns should be wound on to large bobbins before being twisted. The advocates for it urge, with reason, that if very large bobbins can be placed on the pegs of the twisting frame, there is much less risk of single yarn being allowed to run, or of waste being made in pulling it back. Also one girl can mind a greater number of spindles. The opponents allege, also with reason, that to wind the yarn is putting it through an extra process, which may ruffle the fibres, and that it is better to twist it by drawing it off the spinning bobbin the reverse way from that in which it is wound on, which is done when there is no winding, as the loose

fibres then wrap into each other better than when it is pulled off and twisted in the same direction as it is spun. This latter takes place when the yarn has been wound on to other bobbins. The objection seems to be somewhat

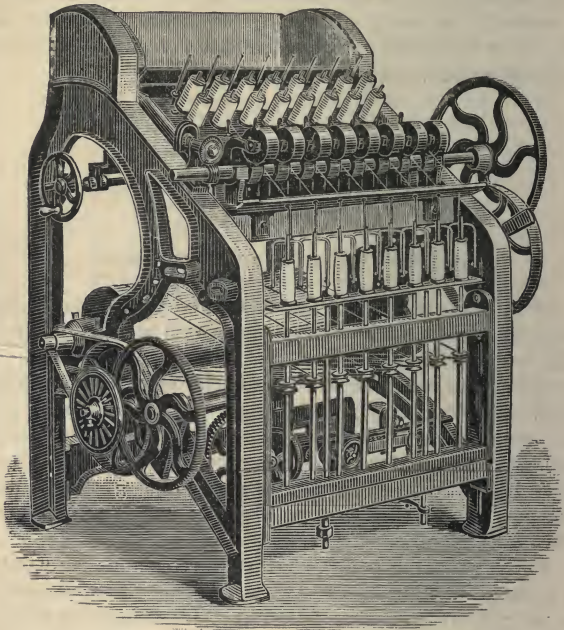

Fig. 67.

the same as that against drafting twice in the same direction, though there is, of course, no draft in twisting. The most satisfactory conclusion seems to be that when the spinning bobbins are large it is hardly worth while to wind the yarn, but where they are small, and the ply more than two-fold, the saving in waste by winding is greater than the expense in wages, and counterbalances



any possible ruffling of the yarn. There are many trap winders for winding either single threads or two or more together, but it is not necessary here to describe them.

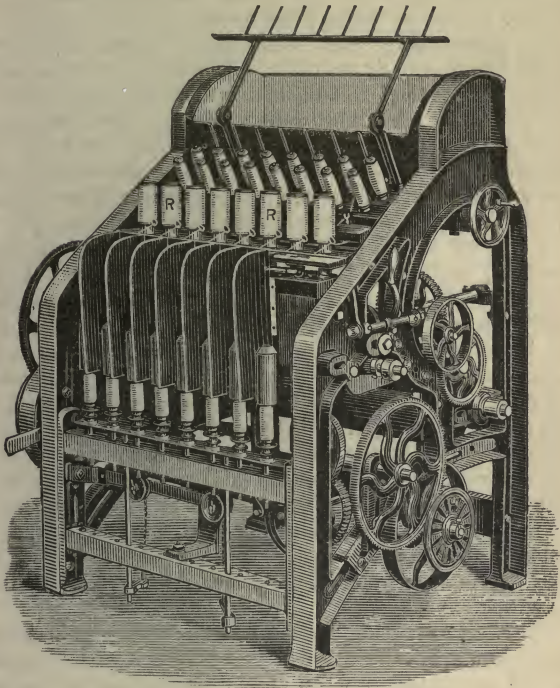

Fig. 68.

186. Roller and Trap Twisters.—Better than any winders for saving waste are trap twisters where the yarn is not very soft, and can support the slight weight of a detector. The old roller twister (Fig. 67) is still found to be best for very soft yarns. It is simply

the spinning frame without the back rollers and carriers, and therefore without the draft, the front rollers and the spindles being the entire machine. The twist is reckoned the same way as in a spinning frame. A better frame is Illingworth's trap twister, which is here shown (Fig. 68) with caps instead of flyers, either being equally suitable. The yarn is wound once round the vertical rollers, R R, which take the place of the ordinarily horizontal rollers of the other frame and regulate the twist by the speed at which they run. They are driven by small bevel wheels below each one, but yet run by friction. A detector is attached to them on a lever; the yarn passes through an eye at one end of it, keeping it down. The roller, R, then revolves, delivering the yarn at a fixed speed; if the thread breaks or runs out, the detector is freed and rises up. The catch in its other end stops the roller, R, but the bevel wheels are not stopped, the friction which communicated motion from them to the roller not being strong enough to stop the wheels, though quite enough to drive the roller when it is free from the action of the detector. This is the commonest form of trap twisting frame for all two-fold yarns, and is one which works well. But it has this defect, that when one end of yarn breaks or runs out, the other must be broken too, and what is called a bunch-knot tied. For most two-folds this does not matter much, though for thick counts it is a drawback.

**187. Stop-motion Twisters.**—The only way in which bunch-knots can be avoided is by stopping the spindle as well as the rollers when an end breaks, and these two must be stopped at precisely the same time, or the broken end cannot be prevented from running down the spindle. The three chief inventors of these stop motions are Messrs. Prince Smith and Son, of Keighley, Messrs. J. and T. Boyd, of Glasgow, and Mr. Unsworth, of Manchester. We cannot here describe in detail the stop motions, and it is the less necessary as their working does

not depend on any adjustment made by the overlooker, but chiefly on their being kept perfectly clean and in good repair. For two-fold, that of Messrs. Boyd is the best; for four to six-fold, that of Messrs. Prince Smith and Son seems to us most serviceable. In the woollen trade Mr. Unsworth's is largely used and much liked. The methods by which they act are, of course, different, but in their main features they are all the same. Each thread passes through a very light detector, which is raised by it. When an end breaks, the detector falls, and is hit by either a rocking bar or a revolving shaft with beaters on it, and is knocked up against a catch which is thereby loosened. This catch is attached to two levers; one works on the front top roller, and the other on the spindle. The former when dropped or raised, as the case may be, lifts the top front roller, and thus prevents the delivery of more yarn. The latter stops the spindle. This can be done in a variety of ways. Messrs. Prince Smith and Son drive this spindle by the friction of a very heavy collar on it against a large leather washer, which rests on the wharl, and they stop the spindle by inserting a wedge which raises this collar up, and at the same time holds it from revolving farther. Messrs. Boyd have two methods, either by slackening the bands by lowering two little pulleys on which each has been running, or by having a tight and loose wharl on each spindle like the pulleys on a frame end, and having a guide fork to knock the belt off the former on to the latter. This is a way which works very well, and is free from some of the objections which can be urged against friction driving. Whatever plan may be adopted, the spindle must stop suddenly and entirely, and yet care must be taken that the bobbin does not overrun itself with the sudden stoppage. The saving in waste from any of these machines is such as to pay for them in a comparatively short time, and they will ultimately entirely supersede all the old twistors. There is a second form of twisting called re-doubling,

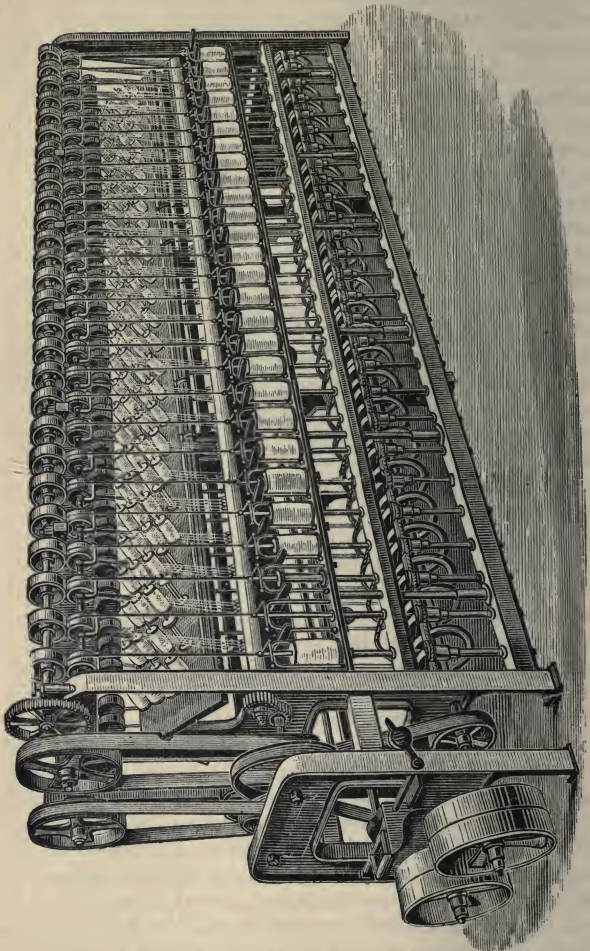

Fig. 69.

which is chiefly used for carpet yarn. It is for twisting two or more threads together that have already been each made into two-fold, the object being to keep them together. For this purpose it is only necessary to put from six to twelve turns per yard into the yarn. The best frame for doing this is Messrs. Boyd's redoubler, of which we give a drawing (Fig. 69). The yarn is taken first through the detectors, and then over the lower top rollers, and down to the bobbins. Owing to the great length between the bobbins on the pegs at the back, and the receiving bobbin, the broken end never can slip down the spindle before it stops. The length between the rollers and the bobbin also ensures regular twist. When the frame traps, the lower top roller falls, and the spindle band is passed from a tight wharl to a loose one, and thus the trap is complete and effective.

188. **Effect of Twisting.**—The twist in a twisting frame must always be put in the reverse way from the spinning twist, or else it would not remain in. The effect, therefore, of twisting is to untwist the single yarn while twisting the two-fold, and this must always be borne in mind, when it is desired to have both a hard single and a hard two-fold, that the harder the two-fold the more twist will be taken out from the single. Yarn must always lose a little length in twisting, the loss being proportionate to the thickness of the yarn and the hardness of the twist, and therefore, of course, varying with every count. If two bobbins of the same counts are twisted together, the count will, of course, become half of what it was before, just as the weight will be double. Thus two-fold 40's is equal to single 20's, not allowing for running up of the twist. When different counts are twisted together, to find the count of the combination multiply the numbers of the two counts together and divide the product by the sum of the two added together. Thus, if 16's and 32's be twisted together,

$$\frac{16 \times 32}{16 + 32} = \frac{512}{48} = 10\frac{2}{3};$$

or if it be desired to obtain a given count in two-fold, and one of the two single threads is known, but not the other, then multiply the known thread and given count together, and divide the product by the difference between these two numbers, and the answer will be the unknown count which was wanted. Thus, if it is desired to have a 36's yarn in two-fold, of which one thread must be 60's, then

$$\frac{60 \times 36}{60 - 36} = \frac{2160}{24} = 90,$$

which is the other count required.

189. **Reeling.**—About reeling not much need be said. The length varies from one to twelve yards, and the forms of making up, leasing, and tying are endless. The common form for single yarn on a one-yard swift is to reel a full hank of 560 yards, divided into seven leas or raps of eighty yards each. There are wheels at the end of the swift which work round at any rate they may be set to, and at the end of every revolution cause the guide rod of the reel to shift a short distance to mark the commencement of a new lea or rap. To set these wheels, and find the proper change wheel, it is necessary always to bring them round to the point they started from, when the reel is ready to be doffed. To find the number of revolutions two wheels geared into each other must make before they return to their original position, divide the product of the number of teeth in each wheel by their greatest common divisor; and this quotient, divided by the number of teeth in each wheel, will give the number of revolutions which that wheel must make to return to its starting-point. Take a 36 and a 48; then  $\frac{36 \times 48}{12} = 144$ . And  $\frac{144}{48} = 3$ , and  $\frac{144}{36} = 4$ , which are the number of revolutions these wheels must make to return to their original positions.

190. **Gassing and Scouring.**—Gassing, or genapping, and scouring yarn are operations requiring much care. The former process is used for heald and other yarns, to

remove all the loose hairs, and make them perfectly smooth. The yarn is wound very quickly off the bobbin on to a swift, and in its transit passes through a gas flame, which slightly singes, but does not at all destroy, the main part of the yarn. After this process it must be scoured or dyed. The gassing can, however, be done with advantage after the dyeing for dark colours. The method of scouring depends on the nature of the wool and the amount of twist in the yarn. For short wool not hard twisted, it is best just to dip the yarn loosely in the warm sud, and then either pass it through rollers or "whiz" it in a hydro-extractor. The softness of the twist prevents it from "jumping" and having a cockled curly appearance. For yarns that are hard-twisted either in the single or two-fold, this simple method will not do. They have so great a tendency to curl and jump that means must be taken to keep them straight. Some persons prefer to scour the yarn on the swift just as it has been reeled, and for this purpose keep a large number of short swifts, so that as fast as one is filled with yarn it can be placed in the suds, rapidly revolved there, then taken out, and made to revolve again quickly, and finally placed in a hot room to dry, after which the yarn is taken off the swift. This plan has the merit of preventing the yarn from shrinking, and also of keeping it quite straight; but sometimes it is desired to let it shrink a little, to give it a fuller or more pearly appearance, in which case another method must be employed. In this the yarn is first well stretched on a sort of rack which can be screwed outwards, so that the yarn is stretched to a slightly greater extent than it was before. Then it is taken off and scoured loose, in a sud not too warm, and wrung out in the hydro-extractor. For hard yarns this is better than press rollers, especially for crewel yarn, which should look full and pearly, for rollers flatten it too much and also wring it unequally. From the hydro-extractor it is taken to the setting frame, an iron stretching apparatus, on which it is

placed, and then screwed out as tight as possible, to stretch out all the curls. This is lowered into a vat of clean boiling water, and the yarn boiled for a short time to set it, after which it will never curl any more. It is then taken off, wrung, and placed on rods, hanging down, with another rod at the bottom of the hank to keep it straight, and it is taken to the hot drying-room, where it is left for perhaps twelve hours till thoroughly dry. By thus being allowed to hang comparatively loose the yarn can shrink without risk of curling, and thus a much fuller appearance is obtained than when it is scoured on swifts. If it is not well dried, the ends will mat together and be spoilt. If it be over-dried it will come back by the natural moisture in the air to its normal condition. In England there is no standard of condition; but in France there are public and official testing establishments where the condition of tops and yarn is tested. It has been found that from the most absolute and perfect dryness which can be obtained without scorching the wool, it will regain  $18\frac{1}{4}$  per cent. of moisture, and that that is its proper and normal condition. Without efficient testing apparatus, it is not easy to be sure that absolute dryness has been obtained, but when the conditions are fulfilled the test is a fair one.

**191. Shrinking.**—The amount that yarn will shrink varies with the wool. Botany wool shrinks very much, and also some sorts of English. The wools that are finer and better suited to felting shrink most. If wool has been dyed and then spun into yarn and scoured, it will not shrink nearly so much as yarn made of undyed wool. This is, of course, because in the dyeing it has already been boiled, and has shrunk a good deal. Woollen yarn often shrinks more than worsted, being made of shorter wool, and it also loses its twist and becomes softer. Twisted yarns also shrink more than single ones. The average shrinking, where no means are taken to prevent it, is from 2 to 5 per cent., and the



yarns, therefore, gain that in thickness. If they are dyed, they often shrink even more, because they are boiled in the process.

192. **Conclusion.**—It is not within the scope of this manual to treat of weaving or the various processes of finishing manufactured goods. These subjects are sufficiently wide to require separate treatment. The many processes required in the worsted and woollen trades before the raw material can be converted into yarn have alone occupied our attention, and we have pointed out the principles underlying each operation. It has not been necessary to enter into the subject of fancy yarns, which are made either by twisting different counts or different materials together, often by means of machinery, which causes loops or knots or other intended irregularities in the folded yarn. Such contrivances are usually patented, and in any case do not come within the general principle of the trade which we have described. All the principles and operations of the spinner have been fully discussed, and we now leave him to dispose of his yarn to the manufacturer. Without the manufacturer the spinner could do little; but without the spinner the manufacturer could do nothing.

## G L O S S A R Y.



- Alpaca.**—The wool of the Peruvian sheep, or Llama, a genus allied to the camel.
- Angora.**—A district in Asia Minor which gives its name to the Angora goat, the hair of which is called mohair.
- Anthracæmia,** another name for wool-sorters' disease, from *anthrax* and *haima* (blood), because the anthrax is found in the blood.
- Back-washing.**—Washing wool a second time, but after it has been through one or more operations, and is made into a sliver.
- Barrel of Bobbin.**—The body of the bobbin on which the thread is wound.
- Belt.**—The endless strap (usually of leather, but sometimes of cotton or indiarubber), by which power is transmitted from one pulley to another.
- Blending.**—The mixing of various materials or different qualities of the same material together.
- Boss of a Roller.**—The body of the roller as distinguished from the axle on which it turns.
- Breast of a Card.**—A large roller in a carding machine, intermediate between the "lickers-in" and the first swift.
- Burrs.**—The name popularly given to seeds with bristles or hooks projecting from them, which stick to the fleeces of sheep.
- Can.**—A receptacle of tin, usually cylindrical, from 24 to 36 inches high, and 10 or 12 inches diameter, for holding slivers of wool.

- Cap.**—A steel cup placed with the mouth downwards over the spindle of a cap frame, just large enough to cover the spinning bobbin.
- Carbonisation.**—Burning by acid any vegetable matter which is found in wool.
- Carriage of a Mule.**—That portion of a mule spinning frame which contains the spindles, and travels backwards and forwards.
- Carriers, or Carrying Rollers.**—Small rollers for supporting the slubbing, or roving, between the back and front rollers of drawing machines and spinning frames.
- Carrying Comb.**—The portion of the nip comb which carries the wool from the nip to the circle.
- Cellulose.**—A term applied to the cellular, or vesicular matter found in the nervous centres. It consists essentially of vesicles or cells. It has until lately been presumed to be limited to vegetable structures.
- Condenser.**—That part of a woollen carding machine which separates the wool when it comes off the last doffer into a number of small rovings or rubbings ready for mule spinning.
- Count of Card Clothing.**—The number of wires set in a straight line across a sheet of clothing five inches wide.
- Counts of Yarn.**—The number given to any size of thread according to the number of hanks (560 yards) that weigh 1 lb., *i.e.*, 36's yarn has 36 hanks of 560 yards each in 1 lb.
- Crown of Card Clothing.**—The number of wires in one inch along a sheet of clothing.
- Differential Motion of Cone Drawing.**—The wheels which make a bobbin revolve at a varying speed as it becomes fuller, independently of the flyer.
- Doffer.**—The roller, or cylinder, of a carding machine between any two swifts which carries the wool from the one to the other.

- Draft.**—The drawing out of one or more ends of sliver or slubbing delivered by a pair of rollers into one thinner end by means of another pair of rollers.
- Drag.**—The resistance of a bobbin on the spindle and washer, as it is pulled round by the yarn when it is being spun.
- Drawing.**—The preparation of wool previous to spinning, but after combing or carding.
- Driven.**—A pulley, or wheel, which is driven (though it may itself drive others), and which, if increased in size, causes those which follow it to work at a *decreased* speed.
- Driver.**—A pulley, or wheel, which drives others (though it may itself be driven), and which, if increased in size, causes those which follow it to work at an *increased* speed.
- Extract.**—The wool derived from waste woollen materials which have been woven, or otherwise mixed with cotton or linen.
- Fallers.**—The steel bars with upright pins set in them, which are carried by means of a pair of screws from the back rollers of a gill box to the front rollers, and then fall down to a lower pair of screws, and are carried back again.
- Fancy.**—A roller on a carding machine which acts as a brush to raise the wool out of the swift.
- Felting.**—The property which enables a number of fibres of wool to interlock and join together, so that they form a compact whole, and each fibre cannot be separated.
- Flocks.**—The waste from finishing machines in cloth mills, which is used again to cheapen yarn and make it bulky.
- Flyer.**—A horizontal steel bar with two vertical arms, each with an eye or twizzle at their lower extremities, which is placed on the spindle, and round one arm of which the yarn is wound as it passes on to the bobbin. Owing to its rotatory speed being

greater than that of the bobbin, it puts twist into the yarn.

**Flyer-eye.**—The twist, or curl, which is given to the extremities of the flyer, forming a sort of ring for the yarn to pass through, sometimes called the twizzle.

**Gauge point.**—A fixed number which can be used to shorten calculations for finding the draft and twist of yarn, &c., and which is obtained by condensing all the fixed quantities in any such process of calculation, and extracting from them their result.

**Gill Box.**—A machine for drawing out and levelling wool, either before or after combing. Its essential features are a pair of back and a pair of front rollers, with a set of fallers travelling between them by means of screws.

**Hank.**—A skein of thread of a fixed length, 560 yards for worsted ; 840 yards for cotton, &c., &c.

**Hog.**—The name given to the wool of one-year-old sheep which have not been previously clipped.

**Kemp.**—A solid, glazed, and horny kind of hair which grows on badly-bred sheep, rarely more than two inches long, which cannot be twisted into the thread in spinning, and will not take the same colour when dyed as the rest of the wool.

**Lea, or Rap.**—The parts into which a hank or skein is divided when it is being reeled.

**Leading.**—*Flyer is leading the bobbin* when the former revolves faster than the latter. In cone drawing, either can lead the other, but in all other drawings the flyer must lead.

**Leasing.**—The tying separately of each lea or rap. The band with which this is done is called "lease band."

**Licker in.**—The first rollers of a carding machine which draw or lick-in the wool.

**Lifter.**—The plate which travels up and down the spindles of a drawing box or spinning frame, and on which the bobbins rest, and are thus lifted up and down.

- Lustre.**—The glossy or shiny appearance which alpaca, mohair, and some English wools, such as Lincoln and Yorkshire, possess, and which causes materials made of them to look bright.
- Milling.**—The same as felting; also, the process by which the felting is carried on.
- Mohair.**—The hair or wool of the Angora goat.
- Mule.**—A sort of spinning frame, on which all woollen yarn is spun. Another form of it is also used for cotton and worsted.
- Mungo.**—The worked-up waste from hard-spun or felted cloth, which is used again for low woollen yarns.
- Nip of Comb.**—The portion of the Lister or nip comb which is formed by two plates closing together and drawing the wool which is between them through the fallers.
- Nip of Rollers.**—The point where a pair of rollers touch each other, and where, consequently, they hold or nip the wool.
- Noil.**—The short wool which is separated from the long by a combing machine.
- Picking.**—The travelling of the bobbin up and down the spindle in the process of being filled, so that it may be equally full all over.
- Pot-eye.**—A little cup with a slit in it, set in a spinning frame for the thread to run down, and to avoid friction.
- Ratch.**—The distance between the back and front rollers in a drawing machine or spinning frame.
- Roving.**—The process of drawing next before spinning.
- Saddles.**—The steel bars in a gill box on which the fallers travel.
- Scribbler.**—The name usually given to the first and second cards in the woollen trade.
- Serrations, or Serratures.**—The fine teeth or points which project from the surfaces of fibres of wool, and which interlock with each other in the process of felting.

- Shoddy.**—The worked-up waste of soft woollen or worsted goods which have not been milled, such as stockings, merinos, &c. ; and, also, opened-out spinning waste.
- Sizing.**—The process of dipping a warp into a thin paste composed of flour, starch, or other similar material, in order to give it strength and bind together all loose hairs.
- Sliver.**—A long ribbon of wool drawn out by a gill box and run into a can. It has no twist in it, and clings together by the nature of the wool.
- Slubbing.**—The equivalent of sliver, but with twist in it, and therefore in the form of a slack-twisted rope. It is made by a flyer winding it round a bobbin.
- Snarl.**—A lump of hard spinning waste, caused by the yarn curling round the top of the flyer instead of being wound on to the bobbin.
- Spindle.**—An upright steel rod, on which the bobbin revolves, and at the top of which the flyer is fastened.
- Spool.**—A wooden bobbin, consisting of a barrel and one end with a flange on it, the other end being merely the size of the barrel, to enable the yarn to be drawn off it when lying horizontal.
- Staple.**—A lock of wool formed naturally on the sheep's back by a number of fibres clinging together.
- Strippers.**—Small rollers which run on the top of the swifts of a carding machine, and carry the wool from the workers back to the swift.
- Stud.**—A fixed iron or steel pin or rod, on which a wheel revolves.
- Swift.**—The largest roller of a carding machine. It carries the wool round to the workers from the strippers, and thence to the doffer.
- Throstle.**—A name for the ordinary spinning frame on which English worsted yarn is spun.
- Top.**—A ball of combed wool from which the noil has been separated.

- Traveller.**—A small hook of finely tempered steel, which runs round on the ring of a ring spinning frame, being pulled by the yarn, which is put through it.
- Twit.**—A thin place in a piece of yarn, caused by uneven drawing or too much draft in the spinning.
- Twizzle.**—Another name for the flyer-eye.
- Washer.**—A small round piece of cloth, with a hole in the centre of it, which is placed on the spindle, and upon which the bobbin runs.
- Wether.**—The name given to the wool of sheep of one year old and upwards which have previously been clipped.
- Wharl, or Wharve.**—The small pulley fastened on to the spindle, on which the band runs which drives the spindle.
- Wheel-Draft.**—The wheel by altering which the amount of draft in a machine is changed.
- Wheel-Tooth.**—A wheel which has its circumference covered with teeth.
- Wheel-Twine.**—The wheel by altering which the amount of twist in slubbing or yarn is changed.
- Wheel-Worm.**—A wheel with a thread like that of a screw cut round its circumference.
- Yolk.**—The grease which is found in the wool of sheep, and which comes from perspiration.



# INDEX.



**A**CTION of card wires, 199  
Alpaca, 13, 78  
Apperley feed, 220

**B**ACILLUS anthracis, 21  
Back-washing, 86  
Bailey's noil motion, 115  
Balling box, 117  
— head and creel feed, 216  
Balls for Noble's comb, 98  
Blamire's feed, 213  
Blending, 182, 185  
Bobbin leading flyer, 143  
Bobbins, three sorts, 152  
Botany drawing, 128  
Boyd's twister, 239  
Bramwell's card-feeder, 192  
Burring machine, 189  
— rollers, 83  
Burrs, 47

**C**ALCULATIONS for cone drawing, 142 to 146  
— — draft of drawing, 131  
— — — — gill boxes, 75  
— — — — spinning, 159  
— — general formulas, 159  
— — knockers-off, 126  
— — twist and speed in spinning, 157  
— — twisting different counts together, 241  
— — yarn, 179  
Cap frames, 160  
Carbonisation, 47  
Card, arrangement of, 82  
— clothing, 86, 210-12

Card clothing for lickers-in, 81  
— -feeding machines, 191  
— Grinding of, 207  
— intermediate feeding, 213  
— rollers, Function of, 197  
— Speed of, 88  
— -wires, Action of, 199  
Carding and preparing, Difference of, 85  
— before combing, 78  
— Belgian, 228  
— without combing, 84  
Carriage of mule, 231  
Carrying-comb, 94, 96  
Circles of Holden's comb, 110  
— — Nip comb, 96  
— — Noble's comb, 100  
Clough's gill box, 66  
Combing by hand, 90  
— — Holden's or square motion, 110  
— — Lister or Nip, 91  
— — Noble's, 97  
— — other machines, 116  
Condenser, Belgian, 227  
— Double-rubber, 223  
— Single-rubber, 224  
Cone-drawing, 135  
— Effect of, 141  
— Principle of, 136  
Counts of card clothing, 211  
— — yarn, 178  
Covering rollers, 209  
Crossby's stop motion, 176  
Crown of card clothing, 211  
Cylinders, Movable, 164

**D**ABBING brushes, 105  
 Differential motion, 139  
 Doffers, 82, 195  
 — Double, 225  
 — Function of, 205  
 Double drawing-off rollers, 107  
 — -rubber condenser, 223  
 Draft, Amount of, 131  
 — for woollen yarn, 231  
 — of gill boxes, 73-9  
 Drafting twice the same way, 118  
 Drag, Irregularity of, 156  
 — of bobbin varies, 123, 155  
 Drawing, 118  
 — Open method, 119, 124  
 — without gills, 128  
 Driven, 74  
 Drivers, 74  
 Drying machine, Hot-blast, 39  
 — — Moore's, 42  
 — — Petrie's, 40

**E**VAN and King's card-feeder, 191  
 Extract, 188

**F**ALLERS, 72  
 Fancy, 82  
 — Function of, 82, 203  
 Felting, 3, 11  
 Filletting for last swift, 221  
 Flocks, 188  
 Flyer, 152  
 — Leading bobbin, 144  
 Fox's ring and cap-frame, 170  
 French drawing, 146  
 — — Effect of, 148  
 — — Position of porcupine, 147

**G**ALLIPOLI oil, 45  
 Gassing, 243  
 Gauge points, 133  
 Gill boxes, 62  
 — — Clough's, 66  
 — — Draft of, 73  
 — — Position of rollers, 71  
 — — Principle of, 64

Gill boxes, Set of, 68  
 — — Speed of rollers, 65

**H**ARD water, 28  
 Hog wool, 14  
 Hydro-extractor, 43

**I**LLINGWORTH'S twister, 238  
 Intersecting comb, 114

**J**OLY'S process of carbonisation,  
 48

**K**EMPS, 10  
 Knocker-off, 125

**L**ICKERS-IN, 81, 195, 202  
 Lifter motion for rings, 167

**M**AKERS-UP, 64  
 Milling, 11, 85  
 Mitchell's caps, 172  
 — stop motion, 174  
 Mixing willey, 186  
 Mohair, 13, 78  
 Mule spinning for worsted, 176  
 — — — woollen, 229  
 Mungo, 187

**N**IP-COMB, Action of, 93  
 — — how to set it, 95  
 Noble's comb, Defects of, 108  
 — — Feeding, 104  
 — — ground plan, 103  
 Noil, 94

**O**IL, quantity used, 46  
 Oiling, Method of, 70  
 — wool, 44, 182  
 Oleine oil, 45

**P**INS for circles, 100  
 — — fallers, 72  
 Porcupine rollers, 129, 147

Potash for soap, 30  
 Preparing, 62

**R**ABAGLIATI, Dr., on wool-  
 sorters' disease, 21

Ratch, 130

Reeling, 242

Ring doffers, 222

— frames, 166

Roving, 127

Rubbing motion in French drawing,  
 148

**S**COTCH feed, 219

Scouring, 243

Scribbler, 194

Serratures of wool, 3 to 7

Setting finger for mule, 232

— of rollers, 200

Shake willey, 181

Sheep washing, 25

Shoddy, 187

Shrinking, 244

Single-rubber condenser, 224

Slivers, Levelling of, 69

Smith's twistors, 238

Soap adulteration, 27

— cream, 45

— receipts for, 29

— -suds, extraction of oil, 51

Soda for soap, 30

Softening water, 29

Speed of bobbin varies, 123, 142,  
 153

— — boxes to correspond, 135

— — cards, 88

Spinning, Cap frame, 160

— Flyer frame, 151

— General formulas for, 159

— mule for worsted, 176

— — — woollen, 229

— ring and cap combined, 170

— — frames, 166

— stop motions, 173

— the twist, 153

— Three operations in, 150

— Winding on, 154

Square motion, 112

Standard of condition, 244

Stop motions for spinning, 173

— — — twisting, 238

Strippers, 82, 195

— functions of, 206

Swift, 82, 195

— function of, 203

**T**ENTER-HOOK willey, 79

Test for oil, 46

— — soap, 27

Tops, 94, 116

Traveller, 166

Turning rollers, 207

Twisting, 235, 237

Two-spindle gill box, 121

**V**IGOGNE yarn, 185

**W**ASHERS, 155

Washing bowl, Petrie's, 32

— — Dr. Braun's, 36

— — Jefferson's, 35

— — McNaught's, 34

Wether wool, 14

Wheel, crown, 139

— Mangle, 141

— Slubbing, 232

— Worm, 126

Wiesner's experiments, 49

Winding, 235

Wool, causes affecting length and  
 quality, 8

— composed of cells, 3

— different qualities on each sheep,  
 15

— fibrous and porous, 4

— Growth of, 1

— names of qualities, 17

— skin, 20

— soundness of fibre, 10

— -sorters' disease, 21

— — — prevention against, 23

— trueness of breeding, 9

— washing at Verviers, 38

- |   |  |
|---|--|
| Woollen, arrangement of fibres, 56<br>— definition, 60<br>— difference from worsted, 55, 233<br>— Processes to assist form of thread, 60<br>— trade, 181<br>Workers, 82, 195<br>— function of, 206<br>Worsteds, arrangement of fibres, 56<br>— definition, 60 | Worsted, difference from woollen, 55, 233<br>— — not in carding, 53<br>— — — — — milling, 55<br>— Processes to assist form of thread, 59<br>— spun on mule or throstle, 54<br>— Three classes of, 53, 62 |
|---|--|

YOLK, 21, 30



THIS BOOK IS DUE ON THE LAST DATE  
STAMPED BELOW

BOOKS REQUESTED BY ANOTHER BORROWER  
ARE SUBJECT TO RECALL AFTER ONE WEEK.  
RENEWED BOOKS ARE SUBJECT TO  
IMMEDIATE RECALL

DUE JUN 8 1975

JUN 8 REC'D  
UCD LIBRARY

DUE JUN 30 1980

JUN 30 1980 REC'D  
LIBRARY

OCT 27 1999 REC'D

LIBRARY, UNIVERSITY OF CALIFORNIA, DAVIS

3 1175 02447 7203



47018

TS  
1627  
M3

McLaren, W.S.B.  
Spinning woolen and worsted.



